

**Fall 2014 Written Comprehensive Exam
Opti 501**

System of units: MKSA

In this problem you are asked to derive two different versions of the Poynting theorem, one with which you are familiar, and a second version which you may not have seen before. Both versions are derived directly from Maxwell's equations. You should use the general definitions for the sources $\rho_{\text{free}}(\mathbf{r}, t)$, $\mathbf{J}_{\text{free}}(\mathbf{r}, t)$, $\mathbf{P}(\mathbf{r}, t)$, and $\mathbf{M}(\mathbf{r}, t)$; in other words, do *not* assume that the material media are linear, isotropic, homogeneous, etc.

- 2 Pts a) Write Maxwell's macroscopic equations in their most general form. Make sure to specify the relationship among the $\mathbf{D}, \mathbf{E}, \mathbf{P}$ fields, and also that among the $\mathbf{B}, \mathbf{H}, \mathbf{M}$ fields.
- 2 Pts b) Eliminate $\mathbf{P}(\mathbf{r}, t)$ and $\mathbf{M}(\mathbf{r}, t)$ from Maxwell's equations by introducing the notions of bound *electric* charge and bound *electric* current. (At this point the equations should no longer contain the \mathbf{D} and \mathbf{H} fields.)
- 2 Pts c) Dot-multiply one of the curl equations into \mathbf{E} and the other curl equation into \mathbf{B} , then subtract one equation from the other. Manipulate the resulting equation algebraically to produce one version of the Poynting theorem.
- 2 Pts d) Explain (in words) the meaning of the various terms in the Poynting theorem obtained in (c).
- 2 Pts e) Repeat parts (b), (c), and (d), this time introducing the notions of bound *electric* charge and bound *electric* current to replace \mathbf{P} , and also bound *magnetic* charge and bound *magnetic* current to replace \mathbf{M} in Maxwell's equations. (At this point the equations should no longer contain the \mathbf{D} and \mathbf{B} fields.) Dot-multiplication should be carried out with the \mathbf{E} and \mathbf{H} fields.

Hint: The following vector identity will be useful: $\mathbf{B} \cdot (\nabla \times \mathbf{A}) - \mathbf{A} \cdot (\nabla \times \mathbf{B}) = \nabla \cdot (\mathbf{A} \times \mathbf{B})$.

Consider a single element optical system as depicted in Fig. 1. An object in air is located at the vertex of the 1st surface of the optical system, and a stop (also in air) is located at the 2nd surface of the optical system. The radii of curvature of the 1st and 2nd surfaces are $+R$ and $-R$, respectively, where R is a positive number. The index of refraction of the lens material is n . Assume paraxial conditions.

1. (3pt) Obtain an expressions for the power of the system and for the locations of the principal planes P , P' measured relative to the respective vertices of the 1st and 2nd surfaces. Simplify the expressions as much as possible.

Now, an image of the object is formed at Infinity. This condition is used for the remaining parts of the problem.

2. (2pt) What is the index of refraction n needed to form an image at Infinity?
3. (2pt) Sketch the paraxial marginal ray and chief ray.
4. (1pt) Determine the location of the entrance pupil.
5. (2pt) If the object has a height h , what is the angular height of the image as viewed from the exit pupil of the system?

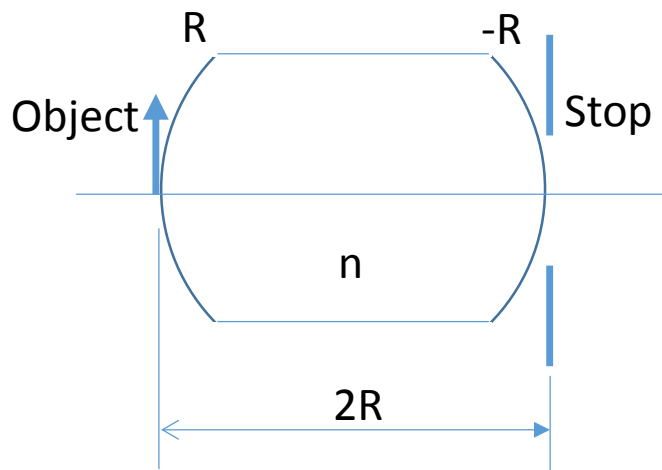

Fig. 1

Fall 2014 Written Comprehensive Exam
OPTI 503

Microscope system (thin lenses in air)

- 1) Design a compound microscope with a magnifying power of 50X using an objective lens with conjugate distances $z=-25$ mm and $z'=125$ mm. Provide the focal length of the objective lens and the eyepiece lens and their spacing. (1 point)
- 2) Determine the position of the aperture stop when the entrance pupil is at infinity. (1 point)
- 3) Then determine the position of the exit pupil. (1 point)
- 4) Layout the microscope showing all the optical components. (1 point)
- 5) If there is -0.001 mm of defocus aberration W_{020} show a plot of the wavefront at the exit pupil. (1 point)
- 6) For an exit pupil diameter of 6 mm and -0.001 mm of defocus W_{020} , what is the distance to the image from the exit pupil? (5 points)

Fall 2014 Written Comprehensive Exam
OPTI 505

The Young's double pinhole interferometer shown below is used to record a fringe pattern on the observation plane when illuminated by a source, where $d = 300\mu\text{m}$, $z_0 = 0.1\text{m}$ and $z_{src} = 1\text{m}$. All measurements are made in air.

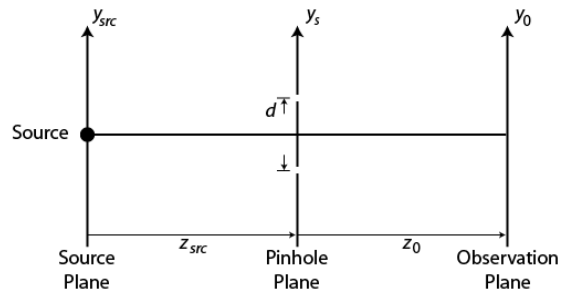

a) (2 pts) The fringe pattern below was recorded for a point source. What is the average source wavelength?

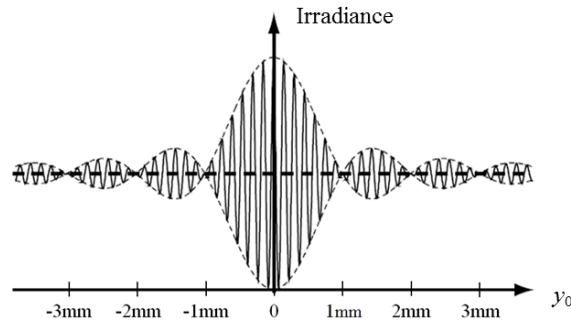

b) (2 pts) For the measurement shown in (a), what is the coherence length in observation space?

c) (2 pts) For the measurement shown in (a), what is the approximate source bandwidth in nm?

d) (2 pts) What is the effect on the irradiance pattern if the point source is moved in the source plane to $y_{src} = 10\text{mm}$?

e) (2pts) What is the effect on the irradiance pattern if the source size in (a) increases from a point to a small, but nonzero diameter spatially incoherent source?

**Fall 2014 Comprehensive Exam
OPTI 507**

Consider a one dimensional crystal with the electronic bandstructure

$$\varepsilon(k) = -A [\sin^2(ka) + \cos(ka)]$$

This band has two extrema in the Brillouin zone that correspond to positive effective masses (which are the same at the two extrema). Find the k -value of one of these extrema and determine the effective mass in units of m_0 (=electron mass in vacuum) at this point, assuming $a = 5 \text{ \AA}$ and $A = 1 \text{ eV}$.

(You may use $\hbar / m_0 = 7.62 \text{ eV \AA}^2$.)

(10 points)

High speed, long distance communication over optical fibers can be realized in the C-band and L-band (1530nm-1625nm), where the propagation loss is lowest. The current best implementation is to use the wavelength division multiplexing (WDM) scheme to achieve high communication bit-rate.

1. Estimate the maximum bit-rate in two standard dense WDM networks over C/L bands having channel spacings of 100GHz (40Gb/s) and 50GHz (25Gb/s), respectively. (2pts)
2. What is the theoretical bit-rate that we can achieve assuming the best use of C/L bands? What do we need to do to achieve this theoretical limit? (2pts)
3. Soliton transmission is an interesting scheme which may allow achieving the theoretical limit bit-rate.
 - Choose one fiber from the table below that can be used to implement soliton transmission. (2pts)
 - Calculate the dispersion length for the bits (optical pulses) in the above DWDM networks (with channel spacing of 100GHz and 50GHz). You can pick any fiber from the list below. (2pts)
 - Estimate the peak power of the bits to form a soliton in the fiber you have chosen for the DWDM network with 100GHz channel spacing (the nonlinear refractive index for fused silica $n_2 = 2.3 \times 10^{-16} \text{ cm}^2/\text{W}$). (2pts)

Typical values at 1550 nm

	Vascade® L1000 Fiber	Vascade® LS+ Fiber	Vascade® LEAF® EP Fiber	Vascade® S1000 Fiber	Vascade® EX1000 Fiber	Vascade® EX2000 Fiber
Description	A high positive dispersion fiber with large effective area	A negative dispersion, NZ-DSF fiber with low, positive slope	A negative dispersion, NZ-DSF with large effective area and positive dispersion slope	A high negative dispersion fiber with negative slope, paired with Vascade L1000 fiber to create a dispersion managed fiber solution	An ultra low loss fiber	An ultra low loss fiber with large effective area
Attenuation (dB/km)	0.187	0.201	0.200	0.235	≤0.174	0.162
Dispersion (ps/nm*km)	+18.5	-3.0	-4.0	-38.0	+18.5	+20.4
Dispersion slope (ps/nm²*km)	+0.06	+0.05	+0.12	-0.12	+0.06	+0.06
Effective area (μm²)	100	48	65	27	76	112
PMDq (ps/√ km)	≤0.05	≤0.05	≤0.05	≤0.05	≤0.05	≤0.05

Hint: You can assume that the bits have a Gaussian temporal shape with duration of approximately 1/bitrate. Following formulas are useful: $L_D = \tau^2 / |\beta_2|$; $L_{NL} = (\gamma P_0)^{-1}$; $\gamma = 2\pi \cdot n_2 / (\lambda \cdot A_{eff})$

Consider a particle in a 1D potential well that is symmetric about the position $x = 0$. $\psi_1(x)$ and $\psi_2(x)$ are **real** and **normalized** ground-state and first-excited-state wavefunctions, respectively, with respective energies E_1 and E_2 . Since the exact form of the potential is not specified and these wavefunctions and energies can therefore not be calculated with the information provided, take these quantities as givens to be used in the expressions below (as needed).

Consider a superposition Ψ defined at time $t = 0$ as

$$\Psi(x, 0) = C[\psi_1(x) + \psi_2(x)].$$

(a - 0.5 pt) Assuming C is real and positive, give a value for C that normalizes $\Psi(x, 0)$.

(b - 1.5 pt) Give an expression for $\Psi(x, t)$, valid for times $t \geq 0$.

(c - 1 pt) Determine the average energy $\langle E \rangle$ for $\Psi(x, t)$.

(d - 2 pts) Determine $\langle E^2 \rangle$ for $\Psi(x, t)$.

(e - 2 pts) Determine the energy uncertainty ΔE for $\Psi(x, t)$, where uncertainty is defined in the usual way as a standard deviation. Simplify as much as possible.

(f - 3 pts) Determine the time-dependent average position $\langle x \rangle(t)$ of a particle in state $\Psi(x, t)$. Defining $a = \int_{-\infty}^{\infty} x\psi_1(x)\psi_2(x)dx$, simplify your expression, giving a final answer that is written in terms of ΔE , a , and trigonometric functions (rather than complex exponentials). Note that $\psi_1(x)$ and $\psi_2(x)$ were specified to be real functions.

Assume you have an MRI system with a uniform static magnetic field strength B_0 . All the spins (water protons with gyromagnetic ratio γ) are fully relaxed and you then apply a resonant 90° RF pulse to excite all spins (spin density $\rho(x,y,z)$) into the transverse plane with an initial phase $\phi=0$ at time $t=0$. You then instantaneously apply a gradient magnetic field such that the total magnetic field is $\underline{\underline{B}} = (B_0 + xG_x)\hat{z}$ for $t>0$.

- What is the precession frequency of spins as a function of their position (x,y,z) at $t=0$ after the RF excitation pulse.
- What is the precession frequency of spins as a function of their position (x,y,z) for times $t>0$ after the gradient is applied?
- What is the phase of spins as a function of their position (x,y,z) and time t for $t>0$?
- Write an expression for the measured signal $V(t)$ (voltage out of the receiver coil) as a function of time starting at $t=0$. You can ignore any signal relaxation during the time of the measurement and the constant of proportionality related to the coil sensitivity.
- The result in part d above fits the linear operator equation $\underline{\underline{g}} = \mathcal{H} \underline{\underline{f}}$. Equate each symbol in this equation with parts of your equation from part d (i.e. what is $\underline{\underline{g}}$, what is \mathcal{H} , what is $\underline{\underline{f}}$).
- What would be the adjoint operator \mathcal{H}^\dagger ? It is probably easiest to define this by writing the equation for $\underline{\underline{\hat{f}}} = \mathcal{H}^\dagger \underline{\underline{g}}$.
- Do you think the reconstruction $\underline{\underline{f}} = \mathcal{H}^\dagger \underline{\underline{g}}$, would yield a "good" image? Why?

Answer the following questions related to radiative transport. The radiative transport equation (RTE), or Boltzmann equation, describes the time evolution of a phase-space distribution function w in terms of four processes: absorption, emission, propagation, and scatter

$$\frac{dw}{dt} = \left[\frac{\partial w}{\partial t} \right]_{abs} + \left[\frac{\partial w}{\partial t} \right]_{emiss} + \left[\frac{\partial w}{\partial t} \right]_{prop} + \left[\frac{\partial w}{\partial t} \right]_{scat} \quad (1)$$

(a) (1 point) What is w a function of and what are its units? What does it describe?

In class, we derived forms for each of the terms in the RTE and wrote an overall spatio-temporal-integro-differential transport equation of the form:

$$\frac{dw}{dt} = -c_m \mu_{total} w + \Xi_{p,E} - c_m \hat{s} \cdot \nabla w + \mathbf{K}w \quad (2)$$

where \mathbf{K} is an integral operator.

(b) (2 points) Write a general expression for the \mathbf{K} operator for both inelastic collisions and elastic collisions.

For the next part, please consider the propagation of photons is limited to one plane (problem is in 2 dimensions and not 3).

(c) (6 points) Consider a point source emitting incoherent light at a constant rate isotropically in all directions in air. A distance R away from point is an ideal thin lens of infinite extent. Assume that scattering in air can be neglected but that absorption cannot be ignored. Write (but do not solve) a RTE that fully describes this system. If you introduce terms, please describe what they are.

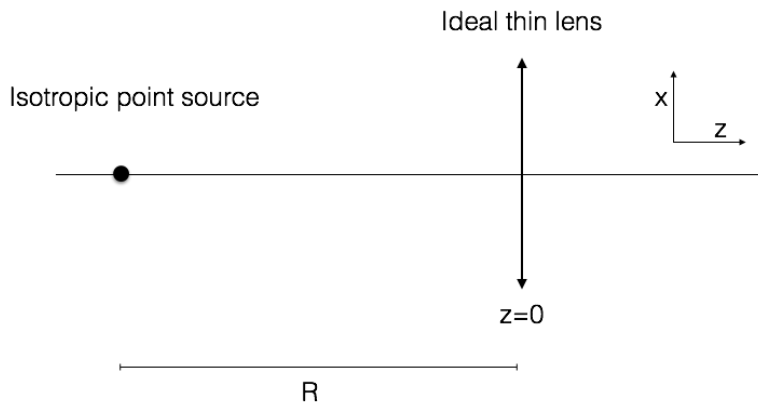

(HINT 1) The source term can be written as $\Xi(x, z, E) = \delta(x)\delta(z + R)\Xi(E)$

(HINT 2) It may be helpful to remember that the ABCD matrix for an ideal thin lens is $\begin{bmatrix} 1 & 0 \\ -1/f & 1 \end{bmatrix}$.

(HINT 3) An ideal thin lens changes the direction of a ray. The only term in the RTE that changes ray direction is the scattering kernel.

(d) (1 point) Generalize your answer above to include an ideal thin lens with chromatic aberration.

Consider a particle in a 1D potential well that is symmetric about the position $x = 0$. $\psi_1(x)$ and $\psi_2(x)$ are **real** and **normalized** ground-state and first-excited-state wavefunctions, respectively, with respective energies E_1 and E_2 . Since the exact form of the potential is not specified and these wavefunctions and energies can therefore not be calculated with the information provided, take these quantities as givens to be used in the expressions below (as needed).

Consider a superposition Ψ defined at time $t = 0$ as

$$\Psi(x, 0) = C[\psi_1(x) + \psi_2(x)].$$

- (a - 0.5 pt) Assuming C is real and positive, give a value for C that normalizes $\Psi(x, 0)$.
- (b - 1.5 pt) Give an expression for $\Psi(x, t)$, valid for times $t \geq 0$.
- (c - 1 pt) Determine the average energy $\langle E \rangle$ for $\Psi(x, t)$.
- (d - 2 pts) Determine $\langle E^2 \rangle$ for $\Psi(x, t)$.
- (e - 2 pts) Determine the energy uncertainty ΔE for $\Psi(x, t)$, where uncertainty is defined in the usual way as a standard deviation. Simplify as much as possible.
- (f - 3 pts) Determine the time-dependent average position $\langle x \rangle(t)$ of a particle in state $\Psi(x, t)$. Defining $a = \int_{-\infty}^{\infty} x\psi_1(x)\psi_2(x)dx$, simplify your expression, giving a final answer that is written in terms of ΔE , a , and trigonometric functions (rather than complex exponentials). Note that $\psi_1(x)$ and $\psi_2(x)$ were specified to be real functions.

Fall 2014 Written Comprehensive Exam Opti 546

This problem involves a plane-wave $E_0 e^{ikz}$ propagating along the z-axis that impinges upon a screen at $z = 0$ with field transmission $t(x')$, resulting in a field just after the screen $E(x', z = 0) = E_0 t(x')$. The screen and field are assumed homogeneous along the y-axis and we restrict the analysis to one transverse dimension. Then the field in the Fraunhofer region a distance L beyond the screen is given by

$$E(x, L) = \int_{-\infty}^{\infty} dx' E(x', 0) e^{-\frac{ikxx'}{L}},$$

where for simplicity a prefactor multiplying the integral has been omitted. The following tabulated integral may be of use

$$\int_{-\infty}^{\infty} ds e^{-isq-bs^2} = \sqrt{\frac{\pi}{b}} e^{-q^2/4b}.$$

(a - 2pts) First consider the case of a single Gaussian aperture with transmission $t(x') = \exp(-[x' - x_0]^2/a^2)$, x_0 being the position of the aperture center and 'a' is a measure of the aperture width. Using the information above derive an expression for the diffracted field $E(x, L)$ in the Fraunhofer region. As a check you should find that the diffracted field includes a Gaussian envelope factor $\exp(-x^2/w^2)$, where $w = 2L/ka$.

(b - 2pts) Next consider the case with two Gaussian apertures separated by a distance d with transmission $t(x') = [\exp(-[x' - d/2]^2/a^2) + \exp(-[x' + d/2]^2/a^2)]$. Use your result from part (a) to obtain an expression for the resulting transverse intensity profile $|E(x, L)|^2$.

(c - 1pt) Using your result from part (b) obtain an expression for the spacing Δ between adjacent zeros in the transverse intensity profile.

(d - 3pts) Assuming $d \gg a$ provide a sketch of $|E(x, L)|^2$ versus x indicating key features including the width of the transverse intensity profile and the positions of zeros in the intensity profile.

(e - 2pts) If the Gaussian apertures are replaced by narrow slits *explain* how the overall shape and structure of your plot from part (d) would change.

**Fall 2014 Written Comprehensive Exam
Opti 501**

System of units: MKSA

A monochromatic, linearly-polarized, homogeneous plane-wave is normally incident from free-space onto the flat surface of pure water (refractive index $n = 1.33$, relative permeability $\mu = 1$).

- 2 Pts a) Write expressions for the incident, reflected, and transmitted plane-waves. Specify the k -vector of each beam in terms of the frequency ω , the speed of light in vacuum, c , and the corresponding refractive index.
- 3 Pts b) Use the Fresnel reflection and transmission coefficients to relate the amplitudes of the E - and H -fields of the reflected and transmitted beams to those of the incident beam.
- 3 Pts c) Relate the time-averaged rate-of-flow of electromagnetic energy in each of the three beams to the corresponding E -field intensity $|E|^2$.
- 2 Pts d) Confirm the conservation of energy by showing that the sum of the rates of reflected and transmitted energy flow is precisely equal to the rate of incident energy flow.

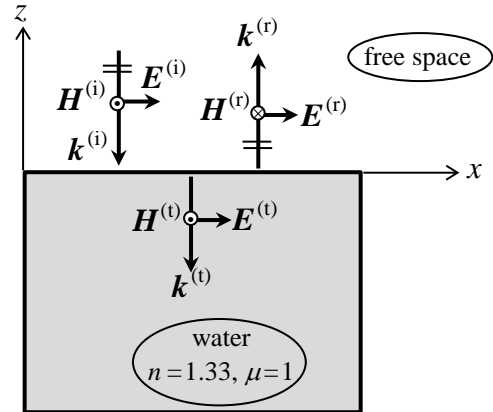

Fall 2014 Written Comprehensive Exam

Opti 502

You need a lens system with a focal length of 38 mm in order to image an object at infinity onto a CMOS detector. However, you can only find thin lenses with focal lengths of 25 mm, 50 mm, 100 mm and 200 mm in the lab. You will need to use two of the available lenses to build the lens system with the focal length of 38mm and an f-number of 4 to perform the experiment. The CMOS detector has 1000x1000 pixels and the pixel size is 3x3 microns. The working wavelength is 0.55 micron.

Assume all lenses are ideal thin lenses without aberrations.

1. Which two thin lenses will you choose to build the lens system? Note that the separation of the two thin lenses must be less than the focal length of either thin lens. (1 point)
2. Assume the lens with shorter focal length is the first element, what is the required separation between two lenses to obtain the desired focal length? What is the distance between the second lens and the CMOS detector? If you reverse the order of the two thin lenses, what is the distance between the second lens and the CMOS detector to obtain good images? (3 points)
3. If you would like to make the lens system telecentric on the image side, where should the aperture stop be placed for the lens system you choose? What is the required diameter of aperture stop? (2 points)
4. What is the object space field of view of the telecentric system you build? Calculate the FOV for the diagonal of the detector. (2 point)
5. What are the required diameters of the two thin lenses for the system to be unvignetted over this FOV? (2 points)

The spectrum emitted by a blackbody with a temperature of 3000 Kelvin is filtered by a band-pass color filter to obtain a narrow-band beam. The filter is centered at 500nm, and has a bandwidth of 20nm. The filter is assumed to have 100% transmission within the band-pass window and zero transmission outside of the filter window. The spectral radiance of a blackbody is given by

$$L(\lambda) = \frac{C_1}{\pi\lambda^5} \frac{1}{e^{C_2/\lambda T} - 1} \quad (\text{watt}/(\text{m}^2 \cdot \text{sr} \cdot \mu\text{m}))$$

where $C_1 = 2\pi hc^2 = 3.741451 \times 10^8 \text{ (W } \mu\text{m}^4 / \text{m}^2 \text{)}$, $C_2 = \frac{hc}{k} = 1.4387 \times 10^4 \text{ (} \mu\text{m} \cdot \text{K)}$,

and T is the absolute temperature in Kelvin. The luminous efficiencies and corresponding xyz color matching functions are given in the Table 1.

Answer the following questions:

- (2 points) Compute the spectral radiance at the five wavelengths listed in Table 1, and the total radiance of the filtered beam;
- (4 points) Compute the luminance L_V , XYZ tristimulus values, and x-y chromaticity coordinate for the filtered beam. This calculation must make use of the spectral data provided in Table 1.
- (4 points) The filtered beam is mixed with a second source that has XYZ-tristimulus values of ($X_R=7500$, $Y_R=3200$, $Z_R=0$) (unit: $\text{watts} \cdot \text{m}^{-2} \cdot \text{sr}^{-1}$). Compute the total luminance, the XYZ tristimulus values, chromaticity coordinates of the new color resulted from the mixing.

Table 1 Selected data for luminous efficiencies and color matching functions

Wavelength (λ) (nm)	Luminous efficiency $v(\lambda)$	x-bar (λ)	y-bar (λ)	z-bar (λ)
490	0.208	0.03201	0.208	0.465
495	0.259	0.0147	0.2586	0.3533
500	0.323	0.0049	0.323	0.272
505	0.407	0.0024	0.4073	0.2123
510	0.503	0.0093	0.503	0.1582

Fall 2014 Written Comprehensive Exam
OPTI 505

- a.) (2pts) Draw and label the essential elements of a Michelson interferometer arranged to view white-light fringes.
- b.) (2pt) Are the fringes in (a) straight or curved? Explain
- c.) (2pts each) Show the basic geometries for testing a flat surface with the following interferometers. Indicate the type of source used.
 - i) Twyman Green
 - ii) Fizeau
 - iii) Mach Zehnder

Fall 2014 Comprehensive Exam

OPTI 507

The dielectric function describing a simple metal can be written as $\epsilon_M = 1 - \frac{\omega_{pl,1}^2}{\omega^2}$, and that of a dielectric as $\epsilon_D = 1 - \frac{\omega_{pl,2}^2}{\omega^2 - \omega_0^2}$ (for simplicity we take the limit of zero damping in this question). Consider a material that does not fall in either of these categories, but rather exhibits metallic response at low frequencies and dielectric response at high frequencies. In other words, a metal with additional high-frequency dielectric response ($\omega_0 \gg \omega_{pl,1}$). Assume $\omega_{pl,1} = 10^{15} \text{ s}^{-1}$, $\omega_{pl,2} = 3 \times 10^{17} \text{ s}^{-1}$, $\omega_0 = 5 \times 10^{17} \text{ s}^{-1}$.

Write down the dielectric function for this system. Then assume that ω is close the plasma frequency $\omega_{pl,1}$ and eliminate the frequency-dependent dielectric contribution by defining a frequency-independent ϵ_∞ . Determine the numerical value of ϵ_∞ and the frequency interval in which the material exhibits large ($R=1$) metallic reflectivity (remember $R = (1-n)^2 / (1+n)^2$). You don't need to formally derive a relation between ϵ and n , just use without proof a simple condition for ϵ that yields $R=1$.

(10 points)

Fall 2014 Written Comprehensive Exam
OPTI 510

Consider the following fused coupler:

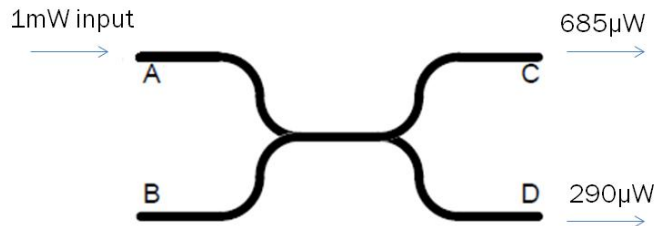

- What is the splitting ratio? (2pts)
- What is the insertion loss from port A to port C? (2pts)
- What is the excess loss? (2pts)
- We would like to use port D as the input port. Assume we put 1mW to port D. Estimate the output power at port A and port B. (4pts)

Consider a laser composed of a stable linear cavity, with 2 mirrors each having power reflectivity coefficients $R_1 = 1$ and $R_2 = 0.95$, and a homogeneously broadened 10 cm long gain medium. The gain medium is a multi-level system as shown in the figure, with population densities N_0, N_1, N_2, N_3 . The lasing transition is between levels 2 and 1. The total population density of this closed system is $N_T = 1 \times 10^{19} \text{cm}^{-3}$. The population transition rates (Γ_{ij}) are also shown, where Γ_{21} is due entirely to spontaneous emission. Note that between levels 1 and 0 there is some population changing process that can drive transitions from $0 \rightarrow 1$ and from $1 \rightarrow 0$ (e.g. collisions) at the same rate Γ_{10} . An external pumping rate P is required for population inversion. The maximum gain cross section for the $2 \rightarrow 1$ atomic transition is $\sigma(\nu_o) = 3 \times 10^{-21} \text{cm}^2$. In this problem, assume that Γ_{32} is infinite (fast decay).

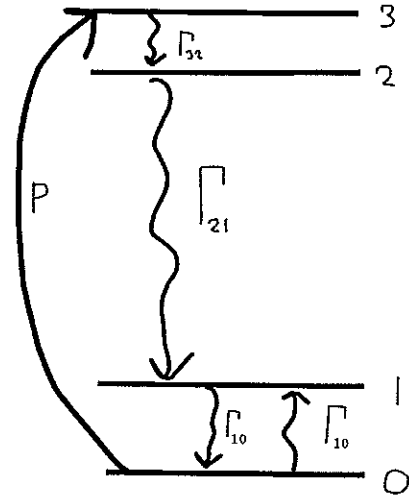

- (a) Write down the relevant population rate equations in the small-signal limit (i.e. do not include stimulated transitions). (20%)
- (b) Using results from part (a), solve for N_2/N_1 in the steady-state, expressed in terms of P, Γ_{21} , and Γ_{10} . (20%)
- (c) Under what condition can a steady-state population inversion be obtained in the limit that $P \ll \Gamma_{10}$? (20%)

For the remaining questions, assume that $P = 10\Gamma_{21}$ and $\Gamma_{10} = 2\Gamma_{21}$.

- (d) Calculate the maximum (on resonance) small-signal gain coefficient. (30%)
- (e) Calculate the threshold gain coefficient. Using your result from part (d) above, determine if lasing action is possible. Justify your answer by clearly showing your work. (10%)

The figure below shows a properly adjusted Koehler illumination system for a microscope with light travelling from left to right.

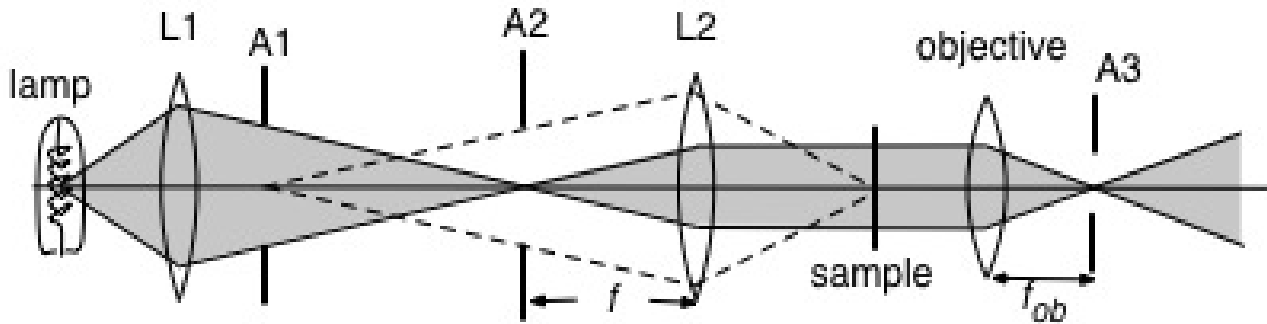

- Identify each of the following elements (1: condenser lens, 2: field aperture, 3: microscope stop, 4: collector lens, 5: condenser aperture).
- Explain what the size of A1 controls.
- Explain what the size of A2 controls.
- Explain what the size of A3 controls.
- The setup shown is for brightfield microscopy. What does brightfield mean, and what is the fundamental property of the object sample that gives rise to image contrast in brightfield microscopy?
- How would you alter this brightfield illumination system to perform darkfield microscopy? Be specific here, what element or elements need to be changed and how so?
- What fundamental property of the sample gives rise to image contrast in darkfield microscopy?
- How would you alter this system to perform phase contrast microscopy? Again, be specific as to what and how elements need to be modified to achieve this.
- What fundamental property of the sample gives rise to image contrast in phase contrast microscopy?

Fall 2014 Written Comprehensive Examination
OPTI-537

Answer the following questions related to solid-state physics and semiconductor detectors. All parts weighted as indicated.

- (a) (10%) What is a Bravais lattice? What is a basis? Write an expression for a translation vector \mathbf{R} that spans the equivalent locations in a real-space (3D) Bravais lattice.
- (b) (10%) Write the expression that defines the relationship between the direct (\mathbf{R}) and reciprocal (\mathbf{G}) lattice vectors for a perfect crystal. Define all terms.
- (c) (10%) Explain what is meant by the 1st Brillouin zone, and write an expression for its volume for an orthorhombic lattice with primitive direct lattice constants $a=3 \text{ \AA}$, $b=4 \text{ \AA}$, and $c=5 \text{ \AA}$.
- (d) (10%) If a macroscopic crystal of the lattice structures in (c) above has dimensions of 3mm x 2mm x 5mm in the $\hat{\mathbf{x}} = \hat{\mathbf{a}}$, $\hat{\mathbf{y}} = \hat{\mathbf{b}}$, and $\hat{\mathbf{z}} = \hat{\mathbf{c}}$ directions respectively, and we invoke Bloch's theorem and Born-Von Karman boundary conditions, what is the spacing between the allowed k_x , k_y , and k_z states? (Express your answer in the customary units of cm^{-1}). How many electrons fit inside a single band in the 1st Brillouin zone of this crystal?
- (e) (20%) Explain the concept known as the Ewald sphere and its utility for explaining the elastic scattering (diffraction) of electrons and light from a crystal.

Then consider a 2D rectangular lattice with primitive lattice constants $a=3 \text{ \AA}$ and $b=4 \text{ \AA}$. Use the Ewald construction to work out the allowed reflections (\mathbf{k}_{out}) if say light has an incident \mathbf{k} vector (in units of \AA^{-1})

$$\mathbf{k}_{inc} = \frac{2\pi}{6} \hat{\mathbf{A}} + \frac{2\pi}{4} \hat{\mathbf{B}},$$

where $\hat{\mathbf{A}}$ and $\hat{\mathbf{B}}$ are the unit vectors in reciprocal space corresponding to directions $\hat{\mathbf{a}}$ and $\hat{\mathbf{b}}$ in real space.

- (f) (10%) What is the wavelength of the light in problem (e) above (in Angstroms?) Approximately what energy is this in eV?
- (g) (15%) Make a sketch that shows the concentrations of majority and minority charge carriers versus temperature ranging from 0K to 500K for a typical crystal of N-type Si semiconductor. Annotate the plot with an explanation of what physical effects are being revealed.
- (h) (15%) Make a sketch of the basic circuit of unit a cell of a CMOS imaging sensor, how the photoelectrons are stored, and how the readout mechanism works. Make a separate sketch showing the potential structure of the PN junction that explains how the device functions as a photodetector. Indicate the relative concentrations of majority and minority carriers in the N and P sides.

Consider a laser composed of a stable linear cavity, with 2 mirrors each having power reflectivity coefficients $R_1 = 1$ and $R_2 = 0.95$, and a homogeneously broadened 10 cm long gain medium. The gain medium is a multi-level system as shown in the figure, with population densities N_0, N_1, N_2, N_3 . The lasing transition is between levels 2 and 1. The total population density of this closed system is $N_T = 1 \times 10^{19} \text{ cm}^{-3}$. The population transition rates (Γ_{ij}) are also shown, where Γ_{21} is due entirely to spontaneous emission. Note that between levels 1 and 0 there is some population changing process that can drive transitions from $0 \rightarrow 1$ and from $1 \rightarrow 0$ (e.g. collisions) at the same rate Γ_{10} . An external pumping rate P is required for population inversion. The maximum gain cross section for the $2 \rightarrow 1$ atomic transition is $\sigma(\nu_o) = 3 \times 10^{-21} \text{ cm}^2$. In this problem, assume that Γ_{32} is infinite (fast decay).

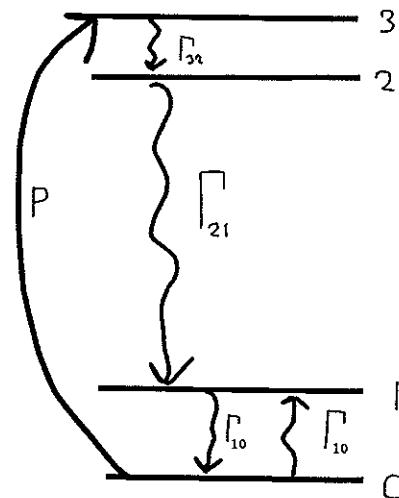

(a) Write down the relevant population rate equations in the small-signal limit (i.e. do not include stimulated transitions). (20%)

(b) Using results from part (a), solve for N_2/N_1 in the steady-state, expressed in terms of P, Γ_{21} , and Γ_{10} . (20%)

(c) Under what condition can a steady-state population inversion be obtained in the limit that $P \ll \Gamma_{10}$? (20%)

For the remaining questions, assume that $P = 10\Gamma_{21}$ and $\Gamma_{10} = 2\Gamma_{21}$.

(d) Calculate the maximum (on resonance) small-signal gain coefficient. (30%)

(e) Calculate the threshold gain coefficient. Using your result from part (d) above, determine if lasing action is possible. Justify your answer by clearly showing your work. (10%)

Fall 2014 Written Comprehensive Exam Opti 546

This problem deals with scattering of a plane-wave of wavelength λ from an acousto-optic cell of length L with spatially periodic refractive-index $\Delta n(x) = n_1 \sin(Kx)$, where n_1 is the magnitude of the index modulation, and $K \ll k$ the magnitude of the wavevector of the acoustic wave, k being the magnitude of the optical wavevector.

(a - 2pts) Sketch the characteristic arrangement of the incident optical field wavevector, acoustic wavevector, and the scattered field components for Bragg diffraction for the situation described above.

(b - 3pts) Considering now Raman-Nath diffraction the field exiting the acousto-optic cell is in the quasi-static approximation

$$\mathcal{E}(x, L) = \mathcal{E}_i e^{i2\pi\Delta n(x)L/\lambda}, \quad (1)$$

where \mathcal{E}_i is the amplitude of the incident plane-wave. Using the Bessel function identity

$$e^{i\delta \sin \phi} = \sum_{m=-\infty}^{\infty} J_m(\delta) e^{im\phi}, \quad (2)$$

with $J_m(\delta)$ the Bessel function of the first kind of order m , show that the field exiting the acousto-optic cell is composed of scattered waves with components of their wavevectors along the x-axis given by $k_x^{(m)} = mK, m = 0, \pm 1, \pm 2, \dots$

(c - 2pts) Based on your solution from part (b) argue that in the far field region beyond the acousto-optic cell the intensity pattern will be composed of scattered waves traveling at angles $\theta_m = mK/k$ with respect to the z-axis, and with intensities $I_m(L) = I_i J_m^2(2\pi n_1 L/\lambda)$, with I_i the incident intensity.

(d - 1pt) Briefly discuss the meaning of the quasi-static approximation alluded to above.

(e - 2pts) Discuss whether the various scattering orders incur any frequency shifts as a consequence of the acousto-optic interaction given a sound frequency Ω .