

**SPECIFICATION FOR COTCO LED LAMP**

Document No : SPE/ LD-701CHR1-A5  
Model No: LD-701CHR1-A5  
Rev. No : 04  
Date: 2005-07-20

Description:

7 x 7mm, QFN Type,  
High Power Red LED For Illumination,  
Clear Compound Encapsulated.

Dice Material: AlGaInP

Confirmed  
by Customer: \_\_\_\_\_

Date: \_\_\_\_\_

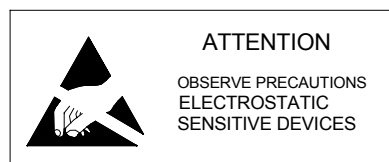

Document No.	SPE/LD-701CHR1-A5
Rev. No.	04

## Features

- High luminous flux output for illumination
- Exposed pad design for excellent heat transfer
- Designed for high current operation
- Reflow soldering applicable

## Package Outline

### Absolute Maximum Ratings at Ta = 25°C (on metal core PCB)\*

Items	Symbol	Absolute maximum Rating	Unit
Forward Current	$I_F$	450	mA
Peak Forward Current**	$I_{FP}$	700	mA
Reverse Voltage	$V_R$	5	V
Power Dissipation	$P_D$	1.2	W
Operation Temperature	$T_{opr}$	-40 ~ +85	°C
Storage Temperature	$T_{stg}$	-40 ~ +85	°C
Junction temperature	$T_j$	+115	°C
Junction-to-Ambient***	$\theta_{ja}$	45	°C/W
Junction-to-case***	$\theta_{jc}$	20	°C/W

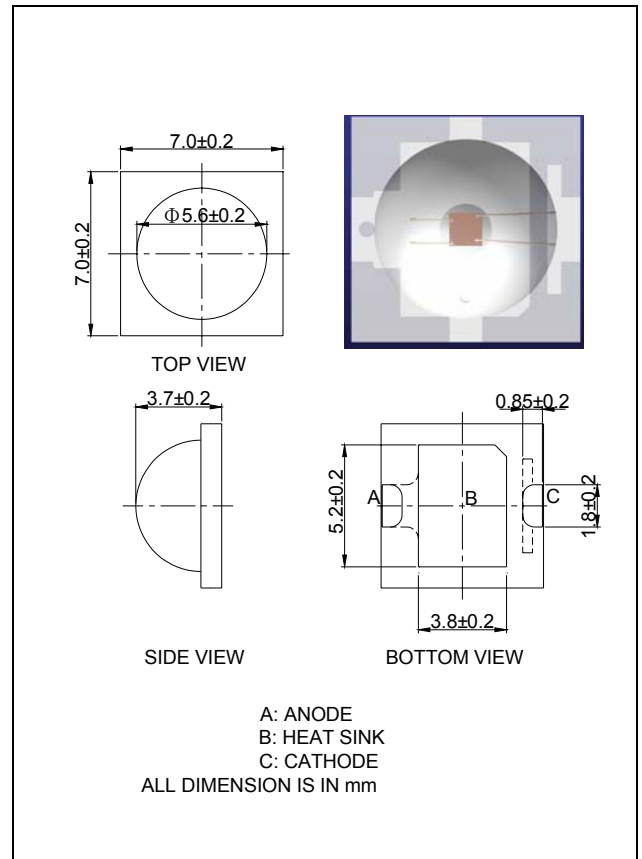

\*Metal core PCB defines as good heat transmission substrate (thickness of 2.0mm Al-based PCB in 20x20mm,  $\theta_{jc} < 20^\circ\text{C/W}$  could do)

\*\* Where pulse width  $\leq 0.1\text{msec}$ , duty cycle  $\leq 1/10$  \*\*\* Rth test condition: mounted on 2.0mm Al-based PCB in size of 20x20mm

### Typical Electrical & Optical Characteristics at Ta = 25°C (on metal core PCB)\*

Items	Symbol	Condition	Min.	Typ.	Max.	Unit
Forward Voltage	$V_F$	$I_F = 450\text{mA}$		2.4	2.8	V
Reverse Current	$I_R$	$V_R = 5\text{V}$	---	---	10	$\mu\text{A}$
Luminous Flux	lumen	$I_F = 450\text{mA}$	21	32	---	lm
Dominant Wavelength	$\lambda_D$	$I_F = 450\text{mA}$	618	624	630	nm
50% Power Angle	$2\theta_{\frac{1}{2}}$	$I_F = 450\text{mA}$	---	105	---	deg

**Ranks Combination ( $I_F = 450mA$ )**

Lamps are sorted to Luminous flux -  $\text{lm}$  & Wavelength -  $\lambda_D$  and rank as below:

\*L+

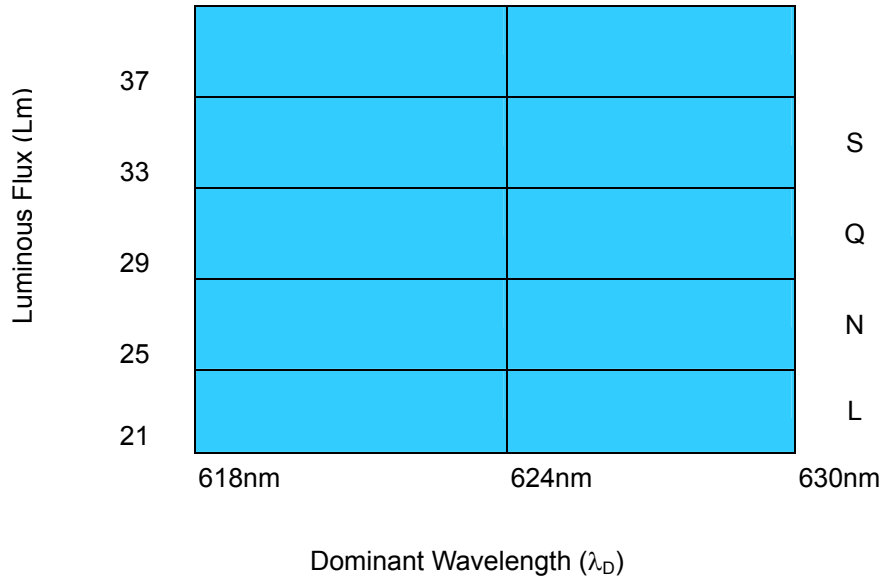

\*L+ indicates Luminous Flux is at L bin or above.

**Forward Voltage (VF)**

Rank	V2	V3
Voltage (V)	2.0 – 2.4V	2.4 – 2.8V

**Important Notes:**

- 1) All ranks will be included per delivery, rank ratio will be based on the dices distribution.
- 2) Pb content <1000PPM.
- 3) Tolerance of measurement of luminous flux is  $\pm 10\%$ .
- 4) Tolerance of measurement of dominant wavelength is  $\pm 1nm$ .
- 5) Tolerance of measurement of Vf is  $\pm 0.1 V$ .
- 6) Packaging methods are available for selection, Please refer to PACKAGING STANDARD.
- 7) Please refer to LED LAMP RELIABILITY TEST STANDARD for reliability test conditions.
- 8) Please refer to APPLICATION NOTES for application.

## Graphs

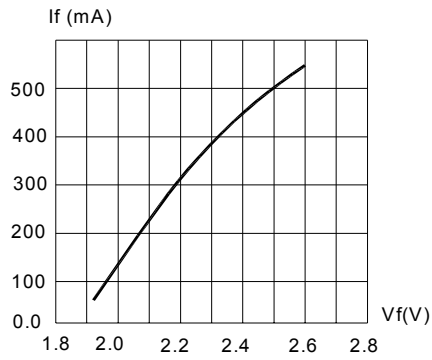

FIG.1 FORWARD CURRENT VS. FORWARD VOLTAGE.

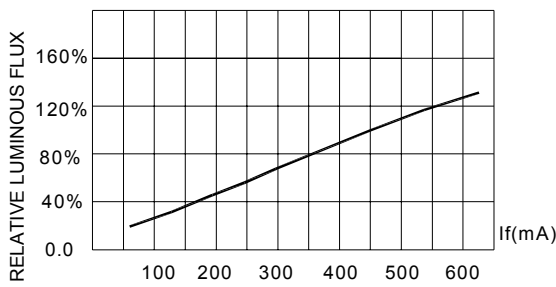

FIG.2 FORWARD CURRENT.

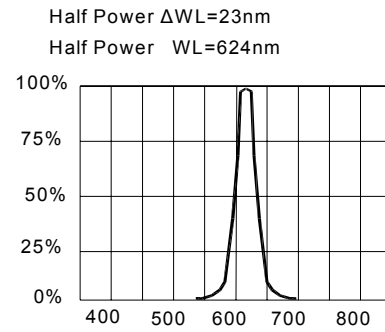

FIG.3 RELATIVE LUMINOUS FLUX VS. WAVELENGTH.

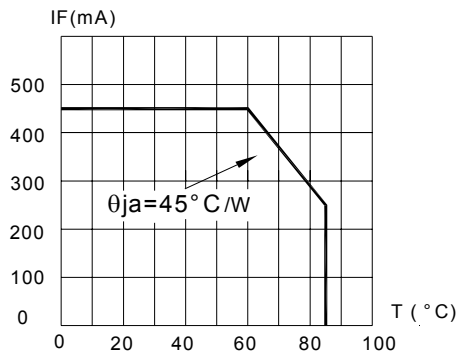

FIG.4 MAXIMUM FORWARD DC CURRENT VS TEMPERATURE. DERATING BASED ON  $T_{jmax}=115^{\circ}\text{C}$

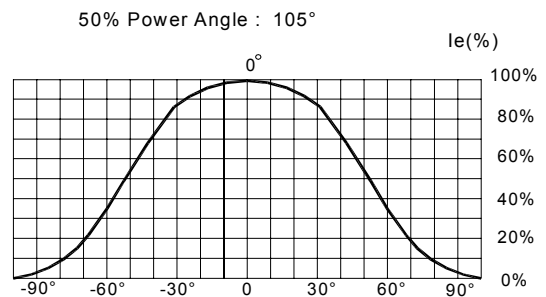

FIG.5 FAR FIELD PATTERN

Items	Signatures	Date	Revision History		
Prepared by	LiuYin	2005-007-20	Rev. No	Date	Change Description
Checked by	ShaBM	2005-07-20	02	2005-02-15	Update derating curve, typical flux value, heading typo error.
Approved by	Thomson	2005-07-20	03	2005-04-22	Change $T_{opr}$ & $T_{stg}$ from $-20 \sim +85$ to $-30 \sim +85$
ECN#	FCN20050197		04	2005-07-20	Adding Junction-to-Ambient Adding Vf range & modifying Graphs Change $T_{opr}$ & $T_{stg}$ from $-30 \sim +85$ to $-40 \sim +85$

Data is subject to change without prior notice; please refer to COTCO Website for the latest version.

Copyright©2002 Cotco International Ltd.