

8

*Mode Hopping in
Semiconductor Lasers*



APPLICATION NOTE



Your Test Connection

Mode Hopping in Semiconductor Lasers

By T.A. Heumier and J.L. Carlsten

Department of Physics
Montana State University
Bozeman, MT 59717

Introduction

Semiconductor lasers find widespread use in fiberoptic communications, merchandising (bar-code scanners), entertainment (videodisc and compact disc players), and in scientific inquiry (spectroscopy, laser cooling). Some applications require a minimum degree of stability of wavelength that is not met by some of these lasers: Under some conditions, semiconductor lasers can discontinuously switch wavelengths in a back-and-forth manner. This is called mode hopping.

In this Application Note, we show that mode hopping is directly correlated to noise in the total intensity, and that this noise is easily detected by a photodiode. We also show that there are combinations of laser case temperature and injection current that lead to mode hopping. Conversely, there are other combinations for which the laser is stable. These results have implications for controlling mode hopping. We also discuss the mechanisms of mode hopping and explain why the photodiode method works.

What is mode hopping?

A semiconductor laser's output spectrum depends strongly on case temperature and injection current. For example, a typical plot of wavelength vs. temperature (Fig. 1) for a GaAs laser at fixed power reveals a stairstep pattern. Note that the wavelength shifts slowly (approximately $0.06 \text{ nm}/^\circ\text{C}$) with temperature in some regions. However, at some values of case temperature, the wavelength may make

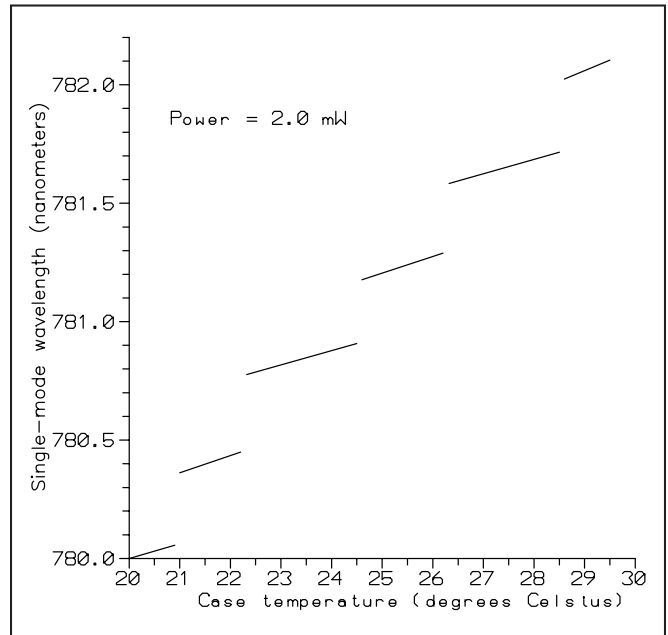

Figure 1. Temperature dependence of single-mode wavelength at constant power.

discrete jumps of 0.3 nm. These large shifts happen when the laser switches from one longitudinal mode to another (mode hopping). Under some circumstances, these mode hops occur in an erratic manner, with the laser switching back and forth rapidly between wavelengths. During mode hopping, the laser's output intensity fluctuates slightly, resulting in an increase in relative intensity noise. We show that a measurement of this noise provides a simple means of detecting mode hops. It will be demonstrated later that mode hopping can occur even when the laser's case temperature and current are tightly controlled.

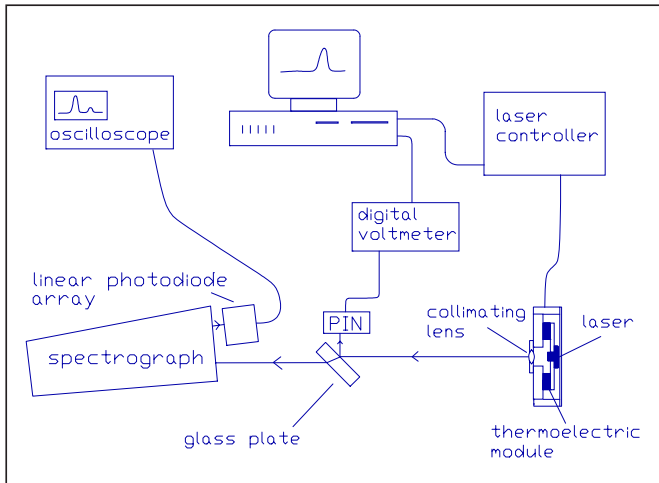

Figure 2. Experimental arrangement for studying mode hopping. The computer was interfaced with both the digital voltmeter and the laser controller.

Motivation for concern about mode hopping

Mode hopping in semiconductor lasers is undesirable in many applications since it introduces unwanted intensity noise. A prime example is in videodisc systems. Mode hopping causes variations in the location of data written to the optical disk because dispersion causes variations in beam direction, possibly requiring the use of achromatic optics¹. In addition, the quality of the picture derived from the disk can be degraded by mode hopping since the signal-to-noise ratio is reduced². Video transmission via fiber optics also suffers from intensity noise produced by mode hopping for the same reason³.

Mode hopping can cause problems in other applications as well. In telecommunications, for example, the switching from one mode to another affects the maximum data transmission rate, because different wavelengths have different velocities in single-mode fibers with high dispersion^{4,5,6}. Spectroscopy is another area that usually requires wavelength stability

better than the 0.2-0.3 nm variation that occurs if the laser shifts from one mode to another.

Parameters affecting mode hopping

Some factors that can affect whether or not mode hopping occurs are laser case temperature, injection current and optical feedback. This Application Note will deal with the first two of these conditions. A brief comment on the last item is that, as a general rule with most lasers, reflections of the laser beam back into the laser cavity should be avoided. Slight canting of any partially or completely reflective surface will help eliminate feedback. Faraday isolators can be used when more effective measures are required.

Experimental study: Methods

We studied mode hopping in diode lasers using the experimental arrangement shown in Figure 2. A Mitsubishi ML 4402 GaAs index-guided laser was housed in an ILX Lightwave Model 4412 laser mount; the laser's case temperature and injection current were manipulated using a computer-interfaced ILX Light

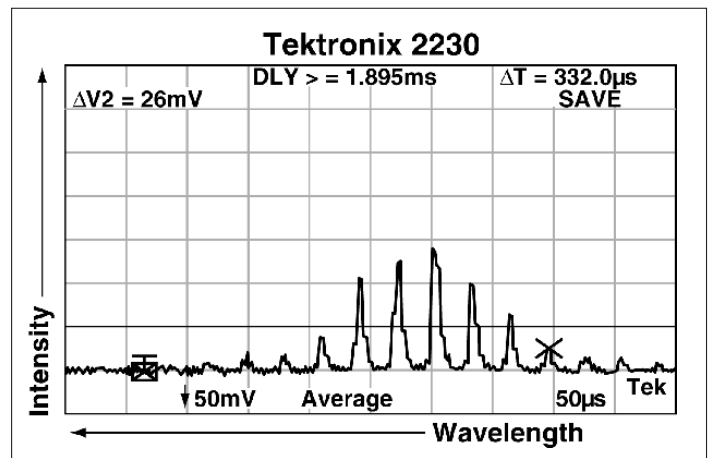

Figure 3. Linear photodiode array output showing laser spectrum just above threshold. Laser modes are separated by 0.3 nm. Small bumps on peaks are individual photodiodes.

wave Model 3722 laser diode controller. The lens in the mount was adjusted to produce a collimated beam. The laser beam passed through a tilted glass plate to a spectrograph. The wavelength-analyzed beam that exited the spectrograph fell on a linear photodiode array. An oscilloscope read the array output to produce a graph of intensity vs. wavelength (see Figure 3). This arrangement facilitated direct observation of the mode structure of the laser.

The beam reflected from the glass plate was collected by a Hewlett-Packard 5082-4203 PIN photodiode whose output voltage was proportional to the intensity of the light (see Figure 4 for a schematic). The voltage was measured by a computer-interfaced Fluke Model 45 digital voltmeter. This voltmeter, capable of registering dc and ac voltages simultaneously, had a 100 kHz bandwidth and could measure to the nearest microvolt.

The computer stepped the injection current at constant case temperature and recorded the voltmeter readings at each current setting. It then changed the case temperature and repeated the process.

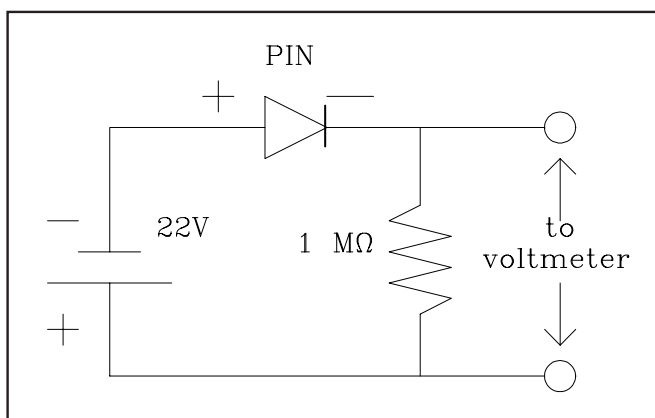

Figure 4. Wiring diagram of PIN photodiode for detection of mode hopping.

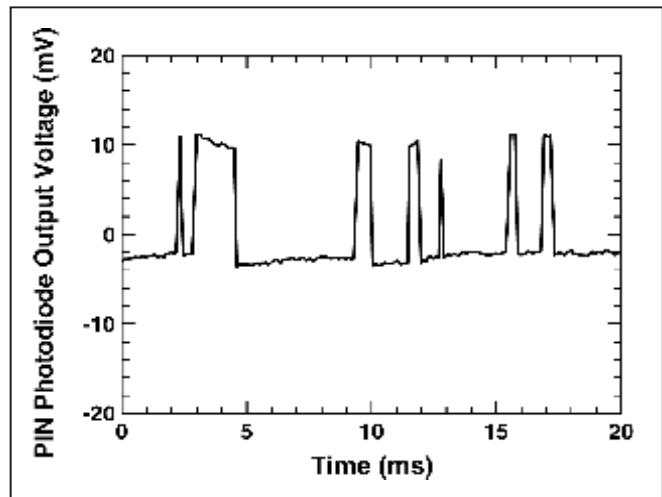

Figure 5. PIN Photodiode voltage output during mode hopping. The laser intensity switched between two intensities as the laser switched between modes. The oscilloscope was ac coupled; the dc voltage was around 5 volts.

Experimental study: Results

While the laser diode was mode hopping, the overall intensity fluctuated slightly. This gave rise to an ac component of the intensity that was measurable with the photodiode. Figure 5 shows a one-shot time series of photodiode voltage while the laser was mode hopping. The ac signal was typically 5 mV, compared to a dc level of 5 V. Figure 6 shows a plot of the ac photodiode voltage vs. injection current with the laser case temperature held constant. The peak occurred when the laser was mode hopping, with the highest point reflecting the most vigorous activity. Thus, an AC voltmeter with microvolt sensitivity in conjunction with a photodiode can be used to detect and to quantify the extent of mode hopping.

It is important to note that, as Figure 6 shows, mode hopping may occur even for strictly controlled conditions if those conditions occur at a point at which the laser is unstable against mode hopping.

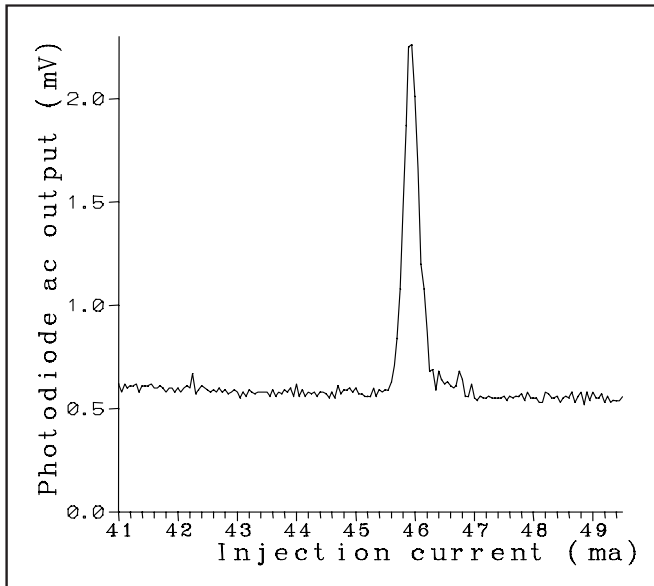

Figure 6. Plot of PIN photodiode ac voltage vs. current at constant temperature. The peak occurs when mode hopping is most vigorous.

The grand stability map. Similar curves taken at different temperatures were plotted in a hidden-line, offset fashion on the same graph. The result, seen in Figure 7 for 0.1 °C increments of case temperature, is a map showing the regions of instability of the laser. There are large areas of stable operation (“plains”) and there are repeated zones of instability (“mountain ranges”). Mode hopping does not occur when the laser operates with the particular combinations of case temperature and injection current that correspond to these areas of stability.

Implications. Superimposed on the plot is a line showing conditions for constant power. It crosses some zones of instability. Neither operation at constant injection current, constant temperature nor constant optical power output suffices to avoid mode hopping. The role of case temperature must be included in any attempt to operate without mode hopping.

Unfortunately, this map varies from laser to laser (see Figure 8). It also may vary as the laser ages. In addition, the ambient temperature plays a small but definite role, shifting the instability zones in the same direction as the ambient temperature. Nonetheless, as Figure 7 illustrates, when mode hopping occurs, one can move the laser’s operating parameters to a region of stability by either changing the case temperature by a small amount (1 degree or less for the laser used to generate Figure 7) or by changing the current by a milliamp or so. Mode hopping can be avoided by proper choice of operating conditions.

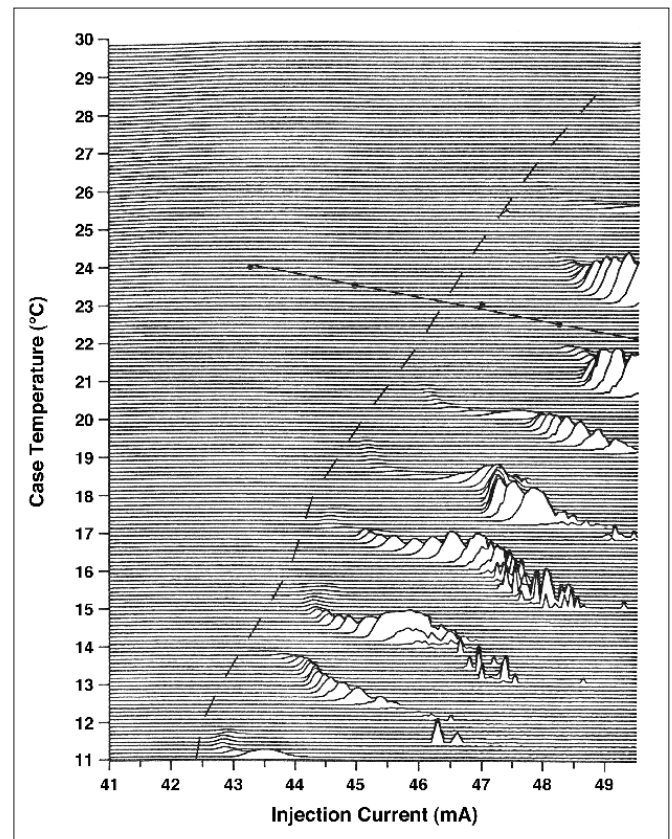

Figure 7. Laser Stability Map. Plots of ac voltage vs. current taken at different temperatures are plotted in an offset, hidden-line fashion. The solid line shows conditions for constant 2 mW laser output.

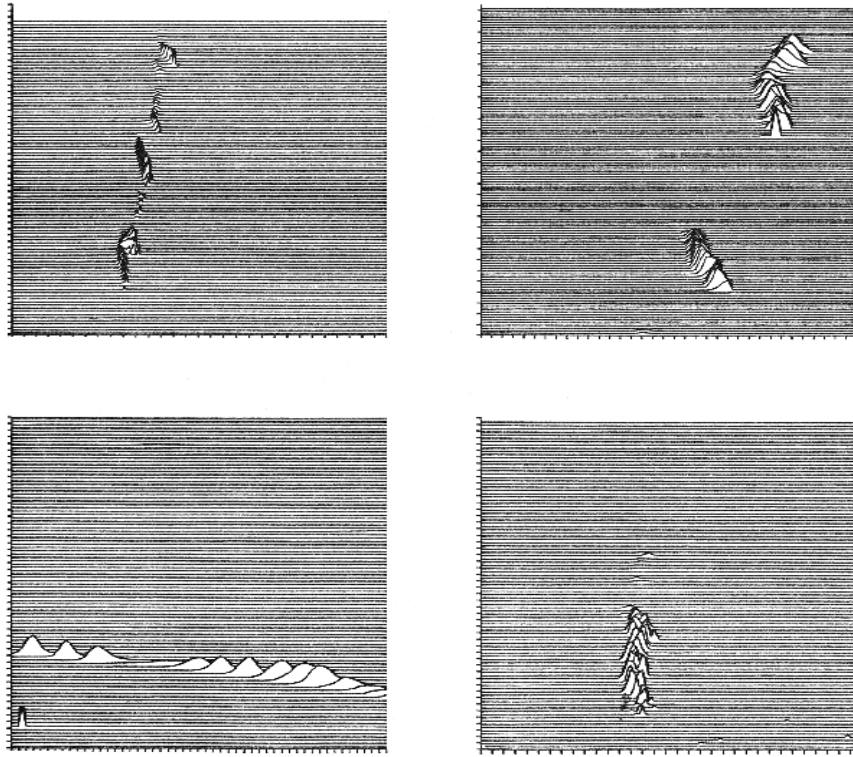

Figure 8. Stability maps of various lasers. Clockwise from upper left: Mitsubishi ML4402, 780 nm (same as grand stability map); Sharp LT026MD0, 780 nm; a second Sharp laser, same model; Mitsubishi ML7781, 1300 nm.

Discussion of map features

Several features of Figure 7 that are evident are (1) The mountain ranges have a negative slope, (2) The centers of the ranges lie on a line of positive slope, and (3) The low-current ends of the ranges form a line, as do the high-current ends. These features can be explained using a simple model which is discussed below. These features and their origins are summarized in Figure 9.

Basic cause of mode hopping. The laser cavity can support many different wavelengths or longitudinal modes. In laser diodes, these modes are separated by 0.2-0.3 nm. It is the wavelength of the peak of the gain profile relative to the mode wavelengths that determines which mode lases. The mode nearest the

gain peak will lase; however, if the gain peak is between two modes, then the modes will compete for gain. Spontaneous emission will tip the balance first in favor of one mode and then the other, thereby causing mode hopping.

Temperature dependence of mode hopping. The mode wavelengths and the gain peak wavelength depend on the laser's temperature: the mode wavelengths shift with temperature at about 0.06 nm/°C, while the gain peak wavelength shifts at about 0.25 nm/°C. The mode shift is due to changes in the index of refraction of the semiconductor as well as the thermal expansion of the material. The latter causes the mode wavelengths to increase as the laser cavity expands. The

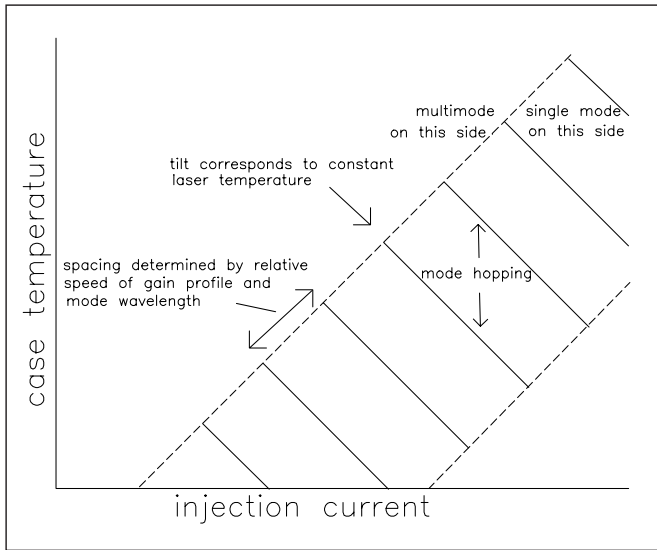

Figure 9. Summary of map features and their origins.

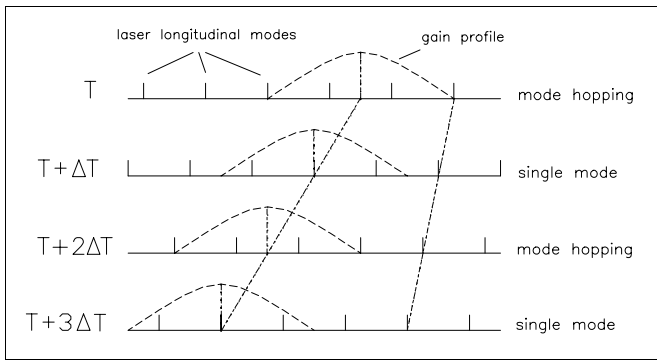

Figure 10. The gain profile and mode wavelengths are temperature dependent. When the gain peak is centered on the mode, the laser runs single mode. When the gain peak is between two modes, the laser mode hops.

gain peak shift is due to the change in the bandgap with temperature⁷. So, as the temperature of the laser increases, the gain peak overtakes the modes one at a time as illustrated schematically in Figure 10. The laser alternates between single-mode operation and mode hopping.

Note that this model assumes that only one mode lases at a time. This is true of index-guided lasers well above threshold, whereas gain-guided lasers operate multimode at all

times. Gain-guided laser diodes don't mode hop, they mode "ooze" as the modes and gain peak shift. Figure 11 illustrates the effect.

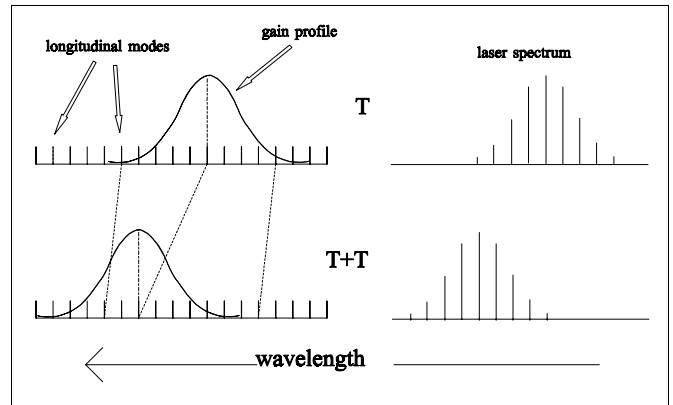

Figure 11. Mode "oozing." The gain profile and longitudinal modes shift with temperature at different rates. The gain profile provides an envelope for the lasing modes.

Negative slope of ranges. As shown above, mode hopping occurs for specific laser temperatures. However, the temperature of the laser itself is not the same as the case temperature. The laser is a very small piece of semiconductor material mounted in the center of the laser package. Since there is electrical current flowing through the laser, there is Joule heating that causes the laser to be hotter than the case⁸. Heat flows from the laser to the case. If the case temperature is increased, the current must be decreased to achieve the same laser temperature. This explains the negative slope of the mountain ranges.

A line of constant laser temperature is plotted on the stability map in Figure 12. It is qualitatively parallel to the mountain ranges, confirming the above hypothesis.

Positive slope of range centers. The laser temperature increases with either current or

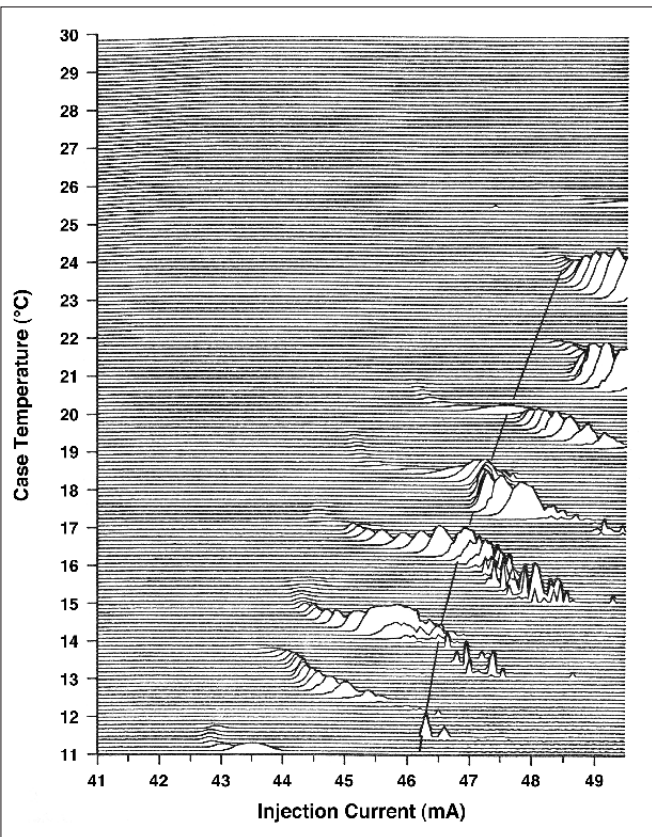

Figure 12. Laser Stability Map. Solid line marks boundary between multimode (to the left) and single mode (to the right) operation. Dots show measured conditions for constant laser temperature; dashed line is best-fit line to data.

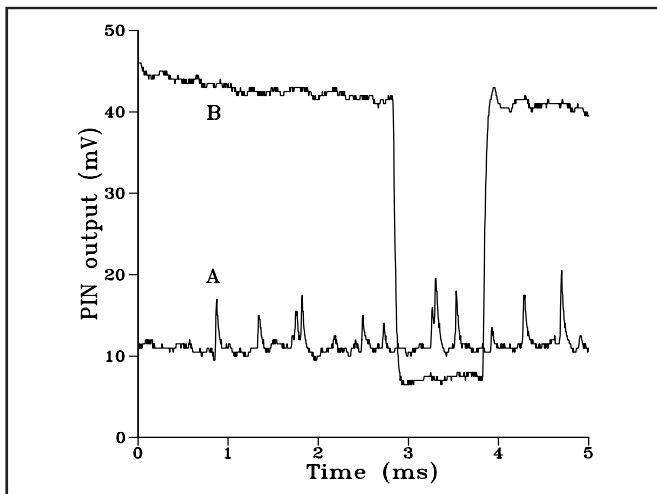

Figure 13. Oscilloscope traces showing total intensity fluctuations. Curve B was taken at the peak of the ac signal, Curve A at a low value.

case temperature. Thus, the centers of the ranges, each corresponding to a different laser temperature, lie on a line of positive slope perpendicular to the lines of constant laser temperature.

Finite extent of mountain ranges. The laser begins operation in multiple modes (see Figure 3). As the current increases, one mode begins to dominate, and the laser ultimately runs single mode. During multimode operation, no mode hopping takes place. Instead, the multiple modes shift as the laser heats up, while the gain profile provides an overall shifting envelope of the mode intensities (see Figure 11). This means that mode hopping regimes have lower bounds of current. The boundary between single mode and multimode operation is shown in Figure 12.

At higher currents, spontaneous emission is less able to trigger switching from one mode to another. If a mode switches from a shorter wavelength to a longer one, the likelihood of a reverse switch is considerably less than at lower currents. The switching becomes markedly less frequent, with seconds or even minutes between switches. Since this infrequent switching generates very little ac voltage, the mountain ranges have a high-current end.

Cause of ac signal. The mere existence of the ac signal itself deserves comment, as does the fact that the size of the signal is well correlated to mode hopping activity. As was mentioned before, the overall intensity of the laser beam fluctuates during mode hopping. The longer wavelength mode exhibits a slightly smaller intensity than the shorter wavelength mode; this causes the variation in intensity

that produces the ac signal as the laser mode hops. An asymmetric gain profile is thought to be partially responsible for this asymmetry in mode intensities⁹.

Cause of ac peak. The ac signal varies in size as the laser moves through mode hopping. This variation is partially caused by radical changes in both the magnitude and time scale of switching during different stages of mode hopping. Figure 13 shows two time series of the photodiode voltage taken at two different injection currents. The lower figure (curve A) was taken when the ac voltage was slightly elevated above the background level. Mode hopping was barely happening, with the laser switching to the next mode for very short times. In contrast, the upper figure (curve B) was taken near the peak ac voltage. Mode hopping was quite vigorous, and the two modes were on for nearly equal times (on average).

Note that the two curves are plotted on the same scale. Distinct differences in the time scales and magnitudes of the fluctuations are evident. In the upper figure, the total intensity alternates between two distinct levels, spending substantial amounts of time at each level before switching to the other level. In contrast, the lower figure shows very frequent and often partial switching between intensities.

When we take the Fourier transform of time series such as these, we find a dramatic difference in the spectral distribution of the noise. Shown in Figure 14 are the Fourier transforms of the corresponding time series. When the laser approaches mode hopping (curve A), the spectral width of the noise is large, corre-

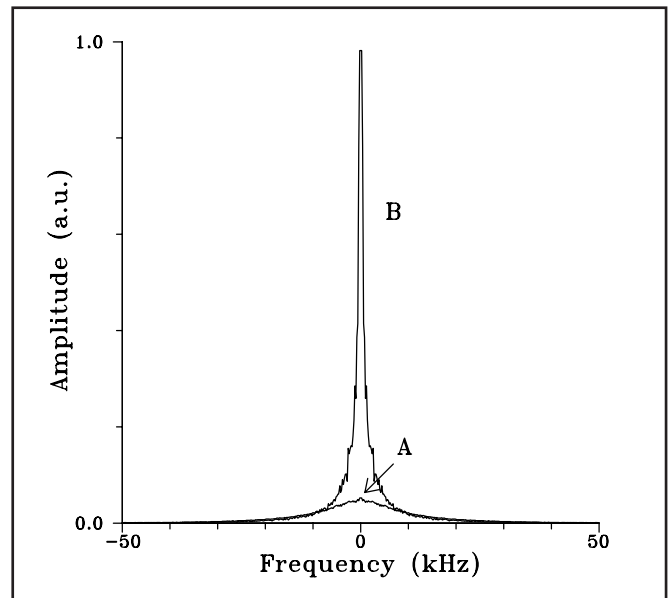

Figure 14. Fast Fourier transforms of the time series shown in Figure 13. Note the large difference in the width and height of spectral densities.

sponding to the wide range of the magnitude and frequency of the intensity fluctuations. At the peak of mode hopping (curve B), the spectral distribution becomes much narrower and larger, since there is not an extremely large variation in the switching times. The low-frequency noise level increases during mode hopping, so the ac signal from the photodiode is a direct measure of mode hopping activity.

Conclusion

Semiconductor lasers find a wide range of applications due to their variety of wavelengths, compact size, low price and ease of control. The rapid switching of wavelength known as mode hopping causes undesirable intensity noise that can limit the performance of these lasers in some applications. The level of intensity noise is directly correlated to the occurrence of mode hopping. A simple, non-spectroscopic method of detecting mode hopping uses the increase in intensity noise

as an indicator. Mode hopping occurs for specific values of laser case temperature and injection current. This means that mode hopping can be eliminated by careful control of these parameters. The stability map (distinct for each laser) is a reliable means of determining which values of the parameters will result in stability. These findings should prove useful whenever mode hopping is a potential problem.

Acknowledgements

We wish to thank Ezra Szöke for the hidden-line algorithm for the stability map and Heather Thomas for acquiring the maps for the other lasers shown in Figure 8. We also thank Meg Hall for acquiring the time series and Fourier transforms shown in Figures 13 and 14, and for many helpful discussions.

Literature cited:

1. Edward C. Gage and Brian Bartholomeusz. "Directional asymmetries due to write-laser mode hopping during optical recording." *Journal of Applied Physics* 69, 569-573 (15 January 1991).
2. T. Gotoh, A. Arimoto, M. Ojima and N. Chinone. "Characteristics of laser diodes and picture quality." *Proceedings of SPIE*, Vol. 329, Issue on Optical Disk Technology, 56-60 (1982).
3. Ken-ichi Sato. "Intensity noise of semiconductor laser diodes in fiber optic analog video transmission." *IEEE Journal of Quantum Electronics* QE-19, 1380-1391 (September 1983).
4. Richard A. Linke, Bryon L. Kasper, Charles A. Burrus, Jr., Ivan P. Kaminow, J-S. Ko, and Tien Pei Lee. "Mode power partition events in nearly single-frequency lasers." *Journal of Lightwave Technology* LT-3, 7066-711 (June 1985).
5. Robert H. Wentworth, George E. Bodeep and

Thomas E. Darcie. "Laser mode partition noise in Lightwave systems using dispersive optical fiber." *Journal of Lightwave Technology* 10, 84-88 (1992).

6. Stewart E. Miller. "On the injection laser contribution to mode partition noise in fiber telecommunications systems." *IEEE Journal of Quantum Electronics* 25, 1771-1781 (1986).
7. Carl E. Wieman and Leo Hollberg. "Using diode laser for atomic physics." *Review of Scientific Instruments* 62, 1-19 (January 1991).
8. Nagaatsu Ogasawara, Ryoichi Ito, Masahiro Kato and Yohshitaba Takahashi. "Mode switching in injection lasers induced by temperature variation and optical feedback." *Japanese Journal of Applied Physics* pt. 1 22, 1684-1690 (1983).
9. Nagaatsu Ogasawara and Ryoichi Ito. "Output power change associated with longitudinal mode jumping in semiconductor injection lasers." *Japanese Journal of Applied Physics* 25, L617-L619 (July 1986).

Further reading about mode hopping:

P.J. Herre and U. Barabas. Mode switching of Fabry-Perot laser diodes. *IEEE Journal of Quantum Electronics* 25,1794 (August, 1989). Corrugation of gain and mode competition.

George R. Gray and Rajarshi Roy. Bistability and mode hopping in a semiconductor laser. *Journal of the Optical Society of America B* 8,632 (March, 1991). Qualitative map of instability plus detailed look at individual mode behavior. Very interesting!

Naoki Chinone, et al. Mode-hopping noise in index-guided semiconductor lasers and its reduction by saturable absorbers. *IEEE Journal of Quantum Electronics* QE-21, 1264 (August, 1985).

G.P. Agrawal and N.K. Dutta, *Long-Wavelength Semiconductor Lasers*. New York: Van Nostrand Reinhold, 1986

Motoichi Ohtsu, Yasuaki Teramachi and Tetsuya

Miyazaki, "Mode stability analysis of nearly single-longitudinal-mode semiconductor lasers," IEEE Journal of Quantum Electronics 24, 716-723 (1988).

Minoru Yamada and Yasuharu Suematsu, "A condition of single longitudinal mode operation in injection lasers with index-guiding structure," IEEE Journal of Quantum Electronics QE-15, 743-749 (1979).

The following publications are available for download on www.ilxlightwave.com.

White Papers

- A Standard for Measuring Transient Suppression of Laser Diode Drivers
- Degree of Polarization vs. Poincaré Sphere Coverage
- Improving Splice Loss Measurement Repeatability

Technical Notes

- Attenuation Accuracy in the 7900 Fiber Optic Test System
- Automatic Wavelength Compensation of Photodiode Power Measurements Using the OMM-6810B Optical Multimeter
- Bandwidth of OMM-6810B Optical Multimeter Analog Output
- Broadband Noise Measurements for Laser Diode Current Sources
- Clamping Limit of a LDX-3525 Precision Current Source
- Control Capability of the LDC-3916371 Fine Temperature Resolution Module
- Current Draw of the LDC-3926 16-Channel High Power Laser Diode Controller
- Determining the Polarization Dependent Response of the FPM-8210 Power Meter
- Four-Wire TEC Voltage Measurement with the LDT-5900 Series Temperature Controllers
- Guide to Selecting a Bias-T Laser Diode Mount
- High Power Linearity of the OMM-6810B and OMH-6780/6790/6795B Detector Heads
- Large-Signal Frequency Response of the 3916338 Current Source Module
- Laser Wavelength Measuring Using a Colored Glass Filter
- Long-Term Output Drift of a LDX-3620 Ultra Low-Noise Laser Diode Current Source
- Long-Term Output Stability of a LDX-3525 Precision Current Source
- Long-Term Stability of an MPS-8033/55 ASE Source
- LRS-9424 Heat Sink Temperature Stability When Chamber Door Opens
- Measurement of 4-Wire Voltage Sense on an LDC-3916 Laser Diode Controller
- Measuring the Power and Wavelength of Pulsed Sources Using the OMM-6810B Optical Multimeter
- Measuring the Sensitivity of the OMH-6709B Optical Measurement Head
- Measuring the Wavelength of Noisy Sources Using the OMM-6810B Optical Multimeter
- Output Current Accuracy of a LDX-3525 Precision Current Source
- Pin Assignment for CC-305 and CC-505 Cables
- Power and Wavelength Stability of the 79800 DFB Source Module
- Power and Wavelength Stability of the MPS-8000 Series Fiber Optic Sources
- Repeatability of Wavelength and Power Measurements Using the OMM-6810B Optical Multimeter
- Stability of the OMM-6810B Optical Multimeter and OMH-6727B InGaAs Power/Wavehead
- Switching Transient of the 79800D Optical Source Shutter
- Temperature Controlled Mini-DIL Mount
- Temperature Stability Using the LDT-5948
- Thermal Performance of an LDM-4616 Laser Diode Mount
- Triboelectric Effects in High Precision Temperature Measurements
- Tuning the LDP-3840 for Optimum Pulse Response
- Typical Long-Term Temperature Stability of a LDT-5412 Low-Cost TEC
- Typical Long-Term Temperature Stability of a LDT-5525 TEC

- Typical Output Drift of a LDX-3412 Loc-Cost Precision Current Source
- Typical Output Noise of a LDX-3412 Precision Current Source
- Typical Output Stability of the LDC-3724B
- Typical Output Stability of a LDX-3100 Board-Level Current Source
- Typical Pulse Overshoot of the LDP-3840/03 Precision Pulse Current Source
- Typical Temperature Stability of a LDT-5412 Low-Cost Temperature Controller
- Using Three-Wire RTDs with the LDT-5900 Series Temperature Controllers
- Voltage Drop Across High Current Laser Interconnect Cable
- Voltage Drop Across High Current TEC Interconnect Cable
- Voltage Limit Protection of an LDC-3916 Laser Diode Controller
- Wavelength Accuracy of the 79800 DFB Source Module

Application Notes

- App Note 1: Controlling Temperatures of Diode Lasers and Detectors Thermoelectrically
- App Note 2: Selecting and Using Thermistors for Temperature Control
- App Note 3: Protecting Your Laser Diode
- App Note 4: Thermistor Calibration and the Steinhart-Hart Equation
- App Note 5: An Overview of Laser Diode Characteristics
- App Note 6: Choosing the Right Laser Diode Mount for Your Application
- App Note 8: Mode Hopping in Semiconductor Lasers
- App Note 10: Optimize Testing for Threshold Calculation Repeatability
- App Note 11: Pulsing a Laser Diode
- App Note 12: The Differences between Threshold Current Calculation Methods
- App Note 13: Testing Bond Quality by Measuring Thermal Resistance of Laser Diodes
- App Note 14: Optimizing TEC Drive Current
- App Note 17: AD590 and LM335 Sensor Calibration
- App Note 18: Basic Test Methods for Passive Fiber Optic Components
- App Note 20: PID Control Loops in Thermoelectric Temperature Controllers
- App Note 21: High Performance Temperature Control in Laser Diode Test Applications

ILX Lightwave Corporation was founded in 1986 as a privately held, venture financed manufacturer of photonic test and measurement instruments. Our commitment to you is to provide the highest quality instrumentation and technical support available.

For application assistance or additional information on our products or services you can contact us at:

ILX Lightwave Corporation

P.O. Box 6310
Bozeman, MT 59771-6310

Toll Free: 1-800-459-9459 in the U.S. and Canada

Phone: 406-556-2481

Fax: 406-586-9405

Email: sales@ilxlightwave.com

Log on to our website at **www.ilxlightwave.com** and quickly get information on all of our products, receive technical support and download Technical Notes, Application Notes, LabVIEW® drivers and other information.

