

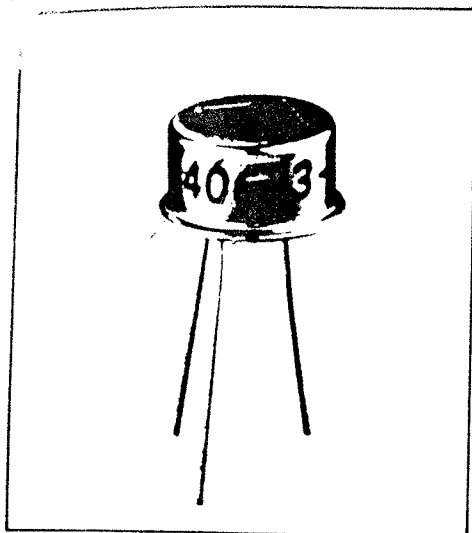

406 Single Element Pyroelectric IR Detector With Source Follower

Manufactured under one or more of the following U.S. patents:
3,839,640 - 4,218,620 - 4,326,663 - 4,384,207 - 4,437,003 -
4,441,023 - 4,523,095



Model 406 contains a single lithium tantalate sensing element and a JFET source follower sealed into a standard TO-5 housing with optical filter.

A patented element mounting technique is used to improve thermal time constant and reduce effects of microphony.

A source resistor is needed to set the drain current and consequently the operating parameters of the JFET. A 47 K Ω or greater value resistor is recommended for connection between output (source) and ground.

Applications

- Motion Sensing
- Lighting Control
- Intrusion Detection
- Industrial Control
- Gas Analysis
- Heating/AC Control
- Pyrometry
- Low-power Laser Detection
- Robotics
- Instrumentation

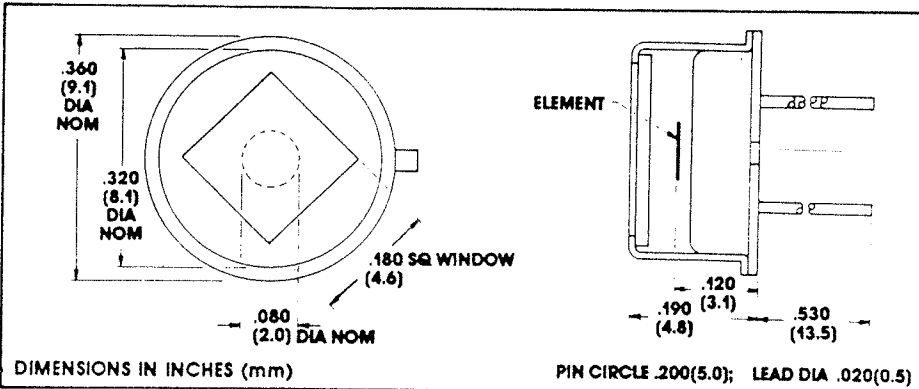
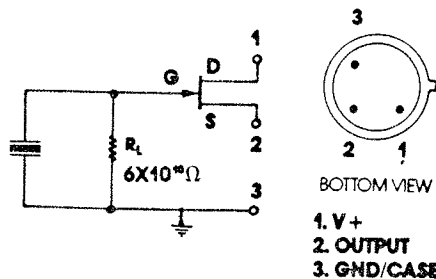

Characteristics	406	Unit	Test Conditions	ELTECdata Reference	
Detector Type	Single	—			
Element Size	2.0	mm, DIA	nominal		
Optical Bandwidth	1.5 to 1000	μm	Various Windows	101	
Responsivity	min typ max	3000 3600 4200	V/W	8 to 14 μm @1Hz	
Noise	typ max	10 20	$\mu\text{V}/\sqrt{\text{Hz}}$	1.0Hz p-p (1 minute)	
NEP	typ max	7.0×10^{-10} 1.7×10^{-9}	W/ $\sqrt{\text{Hz}}$	8-14 μm @1Hz, 8W 1Hz	100
D*	min typ	1.0×10^8 2.5×10^8	cm $\sqrt{\text{Hz}}/\text{W}$	8-14 μm @1Hz, 8W 1Hz	100
Operating Voltage	min max	3 15	V	V _D to Gnd	104 (4.1.c)
Operating Current	min max	0.1 40	μA		104 (4.1.c)
Offset Voltage	min max	0.2 0.8	V	R _S = 22K Ω	104 Fig. 4
Offset Voltage	min max	0.3 1.2	V	R _S = 100K Ω	104 Fig. 4
Output Impedance	max	20	K Ω		
Thermal Breakpoint f _t	typ	0.25	Hz		102
Electrical Breakpoint f _e	typ	0.08	Hz	R _L = 6 x 10 ¹⁰ Ω	102
Recommended Operating Temp.		-10 + 50	$^{\circ}\text{C}$		
Responsivity vs. Temperature	max	+0.2	%/ $^{\circ}\text{C}$	Unity Gain Circuit	104 (3.5)
Pressure Sensitivity	max	200	$\mu\text{V}/\text{mbcr}$	Step Response	
Microphony	max	50	$\mu\text{V}/\text{g}$	10-1000Hz	104 (3.9)
Package Sealing	max	10 ⁻⁸	cm ³ /sec	Helium	
Storage Temperature		-55 + 125	$^{\circ}\text{C}$	$\Delta\text{T} < 5^{\circ}\text{C}/\text{minute}$	

Characteristics at 25 $^{\circ}\text{C}$, with -3 Window, V_D = 5 VDC, R_S = 100K Ω unless otherwise stated. Data is established on a sample basis and is believed to be representative.

FIELD OF VIEW

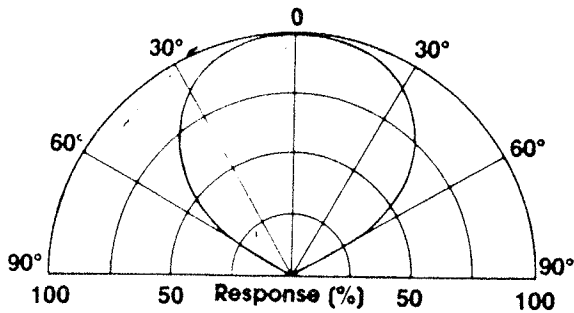

For -3 window only. For other windows, consider refractive index and thickness.

Symmetrical crystal gives same FOV in vertical and horizontal planes.

For best results, the following precautions and recommendations should be observed.

(See ELTECdata 101):

Mounting: Avoid mechanical stresses on case and leads.

Soldering: Use minimum heat and heat sink between case and leads. Leave minimum lead length of .250 inch (6.0mm.) DO NOT MACHINE SOLDER.

Static Discharge: Protect detectors from electrostatic charges.

Thermal Shock: Temperature changes and rate of change must be kept to a minimum (<5°C/min.) to prevent damage.

Light Leakage: Slight sensitivity to visible light leaking through the glass-to-metal seal on the base may be observed.

Transmission Characteristics of -3 Window (HP7)

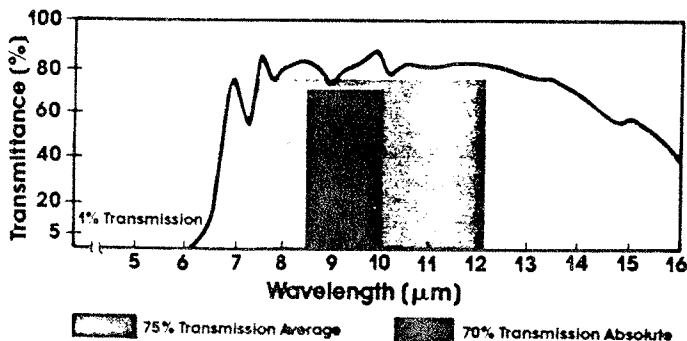

For information on other standard windows available, refer to ELTECdata #101.

FREQUENCY RESPONSE

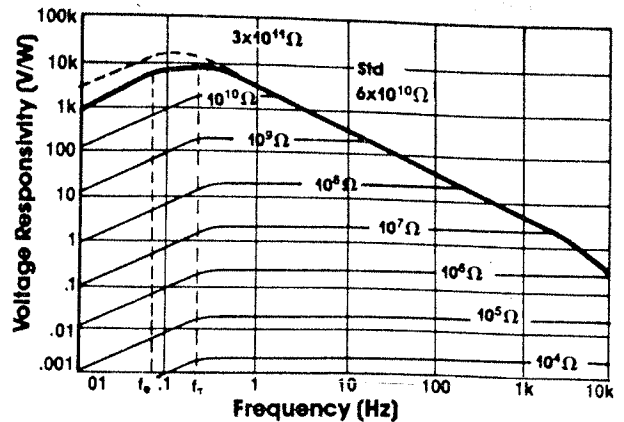

The voltage response of this detector is dependent on the pulse rate or equivalent frequency of input. The frequency response of the detector can be linearized by using a lower value resistor, but at the expense of lower responsivity and a lower D^* . Load resistor values other than the standard $6 \times 10^{10} \Omega$ can be specified.

Noise, as resolution or lower information limit, is not established only by the detector. Other noise sources are:

- Radiated and conducted RF signals
- Subsequent amplification or signal conditioning stages
- Power supply noise
- Components such as high value resistors and tantalum or electrolytic capacitors
- Mechanical contacts and weak solder joints
- Microphonics or vibration
- Outside thermal influences on the detector other than the desired infrared input, i.e. drafts

All these noise sources should be considered carefully when the information signal is <1mV.

Optical Design: Use of a detector with a window in an optical system may require consideration of the image displacement toward the window. This displacement ($= s$) caused by the insertion of a planoparallel plate (window thickness = t ; refractive index = N) is given by $s = (t/N)(N - 1)$.



ELTEC INSTRUMENTS, INC. BOX 9610 DAYTONA BEACH, FLORIDA 32020 TWX 810 / 832 / 6294 (800) 874-7780

POSTFACH 564 CH-8304 WALLISELLEN-ZURICH SWITZERLAND TELEX 826 205 eltc ch (01) 830 00 01
© ELTEC INSTRUMENTS, INC. 1988 Printed in U.S.A.