

USER'S GUIDE

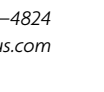
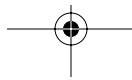
Nanosecond Photodetectors

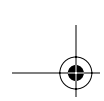
Models 1621 & 1623



NEW FOCUS[®]
Smart Optics for Networks[™]

5215 Hellyer Ave. • San Jose, CA 95138-1001 • USA
phone: (408) 284-6808 • fax: (408) 284-4824
e-mail: contact@newfocus.com • www.newfocus.com





Warranty

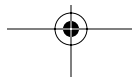
New Focus, Inc. guarantees its products to be free of defects for one year from the date of shipment. This is in lieu of all other guarantees, expressed or implied, and does not cover incidental or consequential loss.

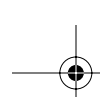
Information in this document is subject to change without notice.

Copyright 2001, 1999, New Focus, Inc. All rights reserved.

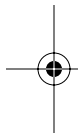
The  NEW FOCUS symbol and NEW FOCUS, Inc. are registered trademarks of New Focus, Inc.

Document Number 162107 Rev. B

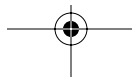


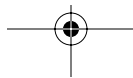
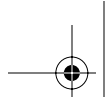


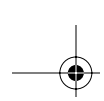
Contents



Operation	5
Introduction	5
Using the Photodetector	7
Conserving Signal Strength	8
Supplying your own load resistor	9
Checking and Replacing the Battery	10
General Features and Principles	11
Photoreceiver Circuitry	11
Frequency and Time Response	11
Using Filters and Optical Fiber	15
Characteristics	17
Physical Specifications	17
Photodetector Specifications	18
Customer Service	19
Technical Support	19
Service	19







Operation

Introduction

The Model 162X is a general-purpose battery-powered photodetector for measuring optical signals down to nanosecond time scales.

There are two versions of the Model 162X detector, each based on a different photodetector diode:

Model	Wavelength	Type	Diam.
1621	350–1000 nm	silicon/PIN	0.8 mm
1623	800–1700 nm	InGaAs/PIN	0.1 mm (with a 1.5-mm ball lens)



Note:

Complete specifications for the Model 162X nanosecond photodetectors begin on page 17.

This product is ideal for detecting light pulses or monitoring optical signals from DC to several hundred MHz where an electronic amplifier is not required. The large-diameter detectors and the DC response make alignment and operation of the Model 162X easy. Figure 1 shows the typical responsivity curves for the photodetectors used in the Models 1621 and 1623.

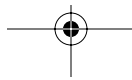
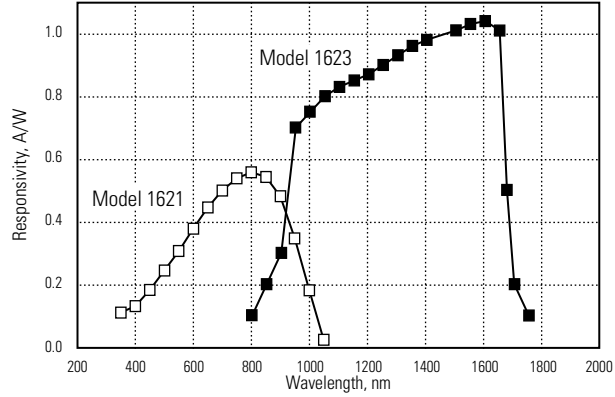
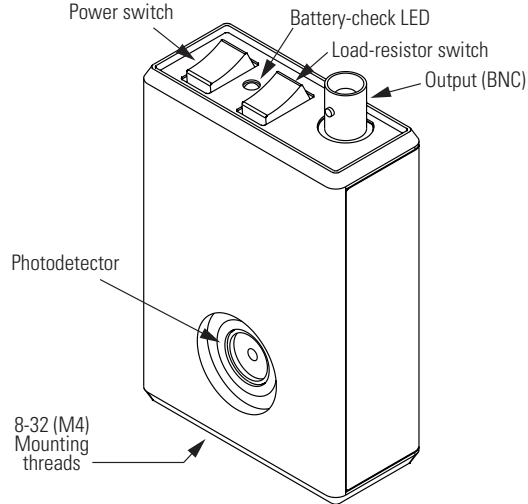


Figure 1:
Typical
responsivities
of
Model 1621
and Model
1623

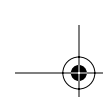


Each Model 162X photodetector runs off a single 9-volt alkaline battery. The photoreceiver's slim casing, shown below, makes it easy to position it in a set-up between closely spaced optics. The switches and BNC output connector are located on top of the receiver for easy access.

Figure 2:
Model 162X
casing



Note: A full mechanical diagram of the Model 162X casing is available on page 17.



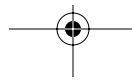
Using the Photodetector

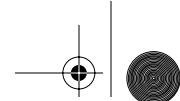
- 1. Check the battery voltage.** The Model 162X is powered by a single 9-volt alkaline battery. To check the battery condition, push the red power switch to the BATT CHK position. If the green LED lights up, the battery is in good condition; if the LED does not light, the battery needs to be replaced (see page 10).
- 2. Mount the photodetector.** Use the 8-32 thread (M4 for metric versions) on the bottom of the casing to mount the photoreceiver to a post or pedestal.



The threading is seated in a non-conductive plastic pad to reduce the electrical noise associated with ground loops. Be careful not to over-tighten when attaching the casing to a post or pedestal, or the threaded insert can strip out of the plastic pad.

- 3. Connect the detector output.** Connect your voltmeter, oscilloscope, or other instrument to the **Output** BNC connector on top of the detector.
- 4. Turn the power switch to “on.”** The output voltage should register on your scope or instrument.
- 5. Align an optical beam onto the detector.** Be careful to keep the optical power under the maximum optical power of 50 mW to avoid damaging the photodetector.
- 6. Select the load.** Use the black switch on top of the detector to set the load to 50 Ω , 10 k Ω , or **Open**. (Select **Open** if you are providing an external load resistor. See “Supplying your own load resistor” on page 9.)
- 7. Turn the detector off.** When you are finished with the detector, return the power switch to the “off” position.





Conserving Signal Strength

If you have a low-power signal, 50 Ω of transimpedance gain can lead to very small output voltages. If you need to conserve signal strength, it is important to focus your optical beam onto the photodiode. Adjusting the photodiode position for optimal signal is best performed as a two-step procedure:

1. Set the load resistance to **10 k Ω or Open**.
2. Hook the detector output directly into an oscilloscope or other voltage-measurement device with a large input impedance.
3. Adjust the photodiode position (in both transverse and focus directions) for maximum DC voltage.

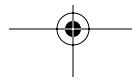
For optical signal levels above about 1 mW (at 10 k Ω), the voltage will saturate. Remember, the output voltage can only rise up to the battery voltage—9 V when the battery is fresh. If you use the 1-M Ω input impedance of an oscilloscope, saturation is even easier to reach.

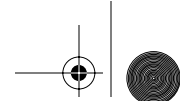
4. Select the 50- Ω resistor, or supply your own small load resistance suitable to your gain and frequency-response requirements. Make fine adjustments to the photodiode position until the maximum signal is achieved.

To compute the approximate output voltage for a given input optical power use the relationship

$$V_{\text{out}} = P_{\text{in}} \cdot R \cdot G,$$

where P_{in} is the input optical power in watts, R is the photodetector's responsivity in A/W (see page 6 for typical responsivities), and G is the load resistance (V/A). For example, with 10 mW of optical power, a responsivity of 0.5 A/W, and with the load set to 50 Ω , the photodetector will produce an output voltage of approximately (10 mW) \cdot (0.5 A/W) \cdot (50 V/A) = 0.25 V.





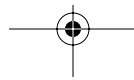
Supplying your own load resistor

At high frequencies, typical resistors begin to exhibit parasitic inductance and capacitance. For instance, if you want to operate on the Open setting and supply your own 100- Ω resistor, you might be tempted to use a standard carbon-film resistor soldered across the terminals of a BNC tee. The problem with this approach is that the parasitic inductance of such a home-made resistor will cause a significant change in the impedance at high frequencies. So, for best results you may need to buy a precision load resistor that is optimized for high-frequency use.

You must also watch out for impedance mismatch problems. The internal transmission line from the photodiode to the BNC output has a characteristic impedance of 50 Ω . This has been chosen for best compatibility with 50- Ω impedance equipment. If you terminate this transmission line with a non-50- Ω load, you should expect degraded frequency response.

When you use 50- Ω impedance equipment, you should switch the nanosecond photodetector into the **Open** position. If you leave the internal 50- Ω resistor switched in, the photocurrent will be divided between the two loads, cutting your signal in half. If you leave the internal 10-k Ω resistor switched in, it will have little effect, as the 50- Ω load will draw the majority of the photocurrent.

DC blocking devices are a potential source of confusion. Some sensitive high frequency equipment requires 0 V at DC input. In this case, we recommend that you put a high-frequency DC blocking load between the nanosecond detector and your equipment. If so, you must supply a DC path to ground for your photocurrent. This is easiest to do by switching in the photodetector's 50- Ω internal load resistor. If you switch in the 10-k Ω load resistor, you must be certain that the circuit does not saturate itself on the DC level.





Checking and Replacing the Battery

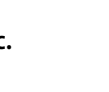
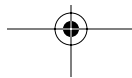
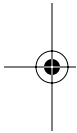
The Model 162X is powered by a single, standard 9-volt battery. The battery lifetime depends on the load resistor and on the optical input power to the photodetector. Under normal operating conditions the battery lifetime will typically be greater than 500 hours.

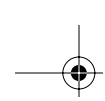
To check the condition of the battery, push the red switch to the **BATT CHK** position. If the green LED lights up, the battery is in good condition.

When the battery voltage falls below about 6.5 volts, the green LED will not light up, and the battery should be replaced.

Replacing the Battery

1. Turn the red power switch to “off” to prevent damage to the receiver.
2. Remove the screw on the back of the photodetector casing and remove the back cover.
3. Unplug the old battery.
4. Install a new 9-volt alkaline battery.
5. Reinstall the back cover.
6. Test the new battery’s status by pushing the power switch to the **BATT CHK** position.





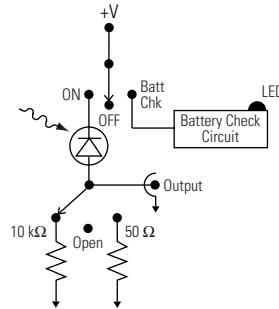
General Features and Principles

Photoreceiver Circuitry

The circuitry inside the Model 162X consists of a reverse-biased photodiode and a load resistor with three settings: **50 Ω**, **10 kΩ**, and **Open**. The **50-Ω** setting has 50-V/A sensitivity and can be used to achieve the ≤ 1 -nanosecond response time. The **10-kΩ** setting has a reduced time response but gives a higher sensitivity (10,000 V/A) and can be used for alignment purposes and for detecting low-power pulses. The **Open** setting allows you to hook-up your own external load resistor and choose the best gain-bandwidth combination for your application.

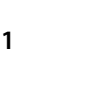
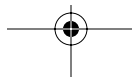


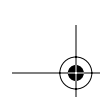
Figure 3:
Functional schematic of the Model 162X circuitry



Frequency and Time Response

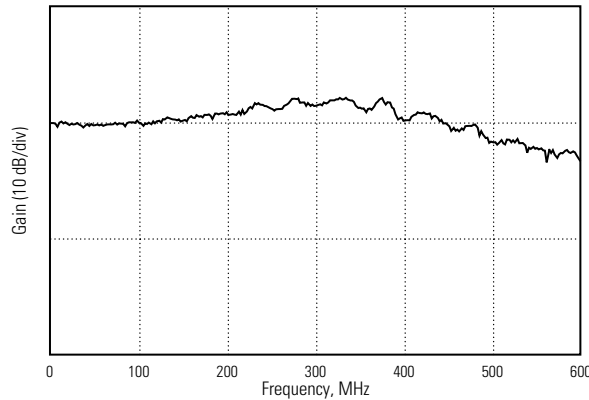
The nanosecond photodetector circuitry is quite straightforward, consisting only of the photodiode, battery bias and a selectable load resistor. The speed limitation of the circuit is established by the junction





capacitance of the photodiode and the load resistance value. Figures 4 and 5 give typical frequency responses and pulse responses for the Model 162X photodetector.

Figure 4:
Typical
frequency
response for
the Model 1623
on the 50- Ω
setting

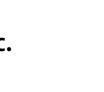
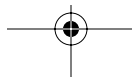


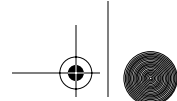
When performing high-speed measurements, impedance-matching effects between your measurement apparatus and the photo-detector must be taken into consideration in order to achieve optimal high-speed response.

Typical laboratory measurement equipment may prevent you from achieving nanosecond response times. BNC connectors do not match 50- Ω transmission lines well for frequencies above 100 MHz. The frequency response is therefore not flat between 100 MHz and 500 MHz.

Above 500 MHz, the situation can be worse, with typical BNC connectors and cables proving to be quite lossy. Therefore, while the time response of the nanosecond detector is quite fast, it is not expected to provide flat frequency response in the 100-MHz to 500-MHz regime.

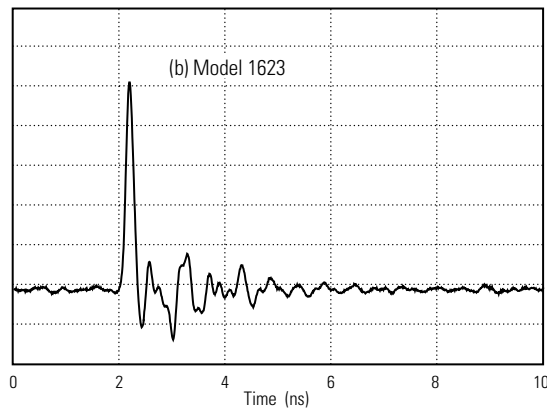
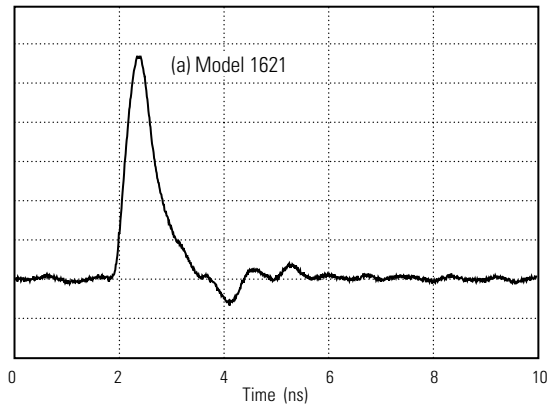
Selecting the internal 50- Ω resistor will usually allow you to achieve a response speed which is limited by your detection equipment. Typical laboratory



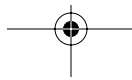


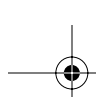
oscilloscopes, for instance, have only 10-MHz to 100-MHz bandwidth. When you select the 10-k Ω resistor, the speed is RC limited, and the response speed will typically be ≥ 50 ns.

Figure 5:
Typical pulse
response for
the (a) Model
1621 and (b)
Model 1623
photodetectors



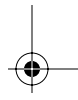
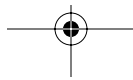
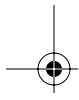
A 0.15-ps pulse at 1.06 μm was used to test the photodetectors, and the output was measured using a 12-GHz oscilloscope.

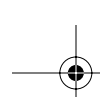




14 • General Features and Principles

NEW FOCUS, Inc.





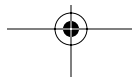
Using Filters and Optical Fiber

New Focus offers accessories, sold separately, to attach a 1"- diameter filter or an optical fiber to the detector. Both accessories attach to the casing using the 1.04-32 threads located in the casing around the detector. Note that the accessories are also compatible with two other New Focus products, the Model 203X large-area photoreceiver and the Model 215X femtowatt photoreceiver.

The Model 1280 1" filter holder allows you to mount a 1"- diameter optic in front of the photodetector. For instance, you can mount a colored glass filter to remove unwanted wavelengths or a neutral-density filter to attenuate the optical power incident on the photodetector. The Model 1280 has a plastic ring for mounting a filter that is up to about 0.25" (6.4-mm) thick. A thicker optic can be held in place using the 6-32 nylon-tipped set screw. Use a 1/16" or 1.5-mm Allen key or ball-driver to adjust the set screw.

The Model 1281 FC fiber adapter allows you to connect an FC connectorized fiber to the front of the photodetector. The coupling efficiency of light from an optical fiber to the Model 1623 photodetector is typically 70% or greater. The coupling efficiency is less than unity because of the small detector size and small variations in the mechanical position of the detector and the fiber.

See Figure 6 for drawings of these two accessories. A variety of fiber couplers, fiber collimators and pigtailed are also available from New Focus.



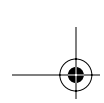
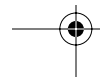
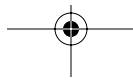
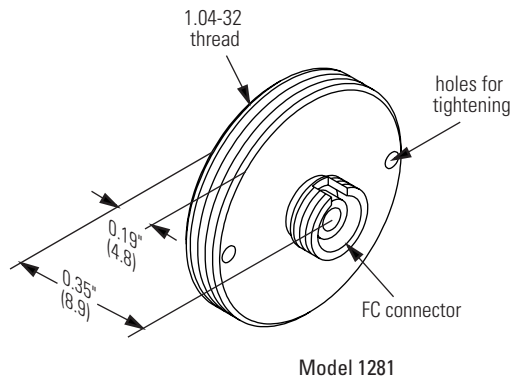
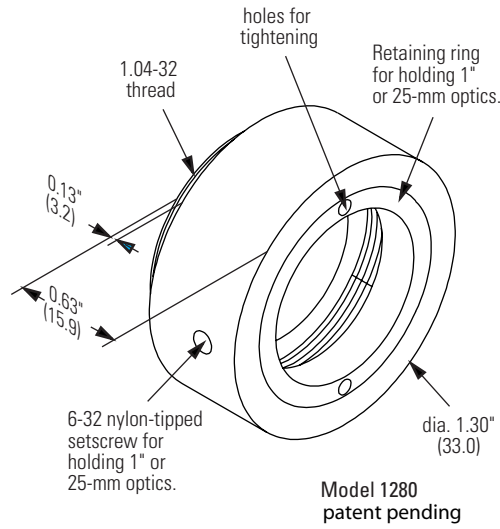
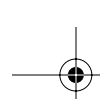


Figure 6:
Model 1280
1" filter holder
and the
Model 1281 FC
fiber adapter

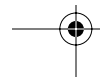
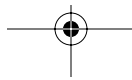
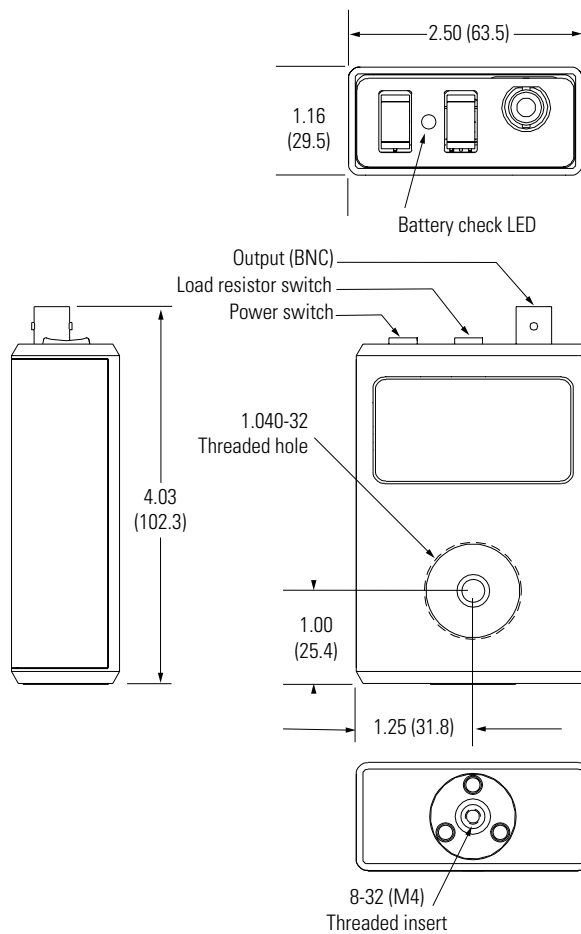


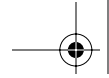


Characteristics

Physical Specifications

Figure 7:
Mechanical drawing of the Model 162X casing

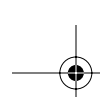




Photodetector Specifications

Model #	1621	1623
Wavelength Range	350-1000 nm	800-1700 nm
Detector Material/Type	Silicon/PIN	InGaAs/PIN
Detector Diameter	0.8 mm	0.1 mm (with 1.5-mm-diameter ball lens)
Typical Max. Responsivity	0.55 A/W (at 800 nm)	1.0 A/W (at 1600 nm)
Maximum Optical Power	50 mW	50 mW
Load Resistors	50 Ω , 10 k Ω , and Open (user provided)	50 Ω , 10 k Ω , and Open (user provided)
Typical Rise Time	≤ 1 nanosecond (50- Ω setting)	≤ 1 nanosecond (50- Ω setting)
Typical detector capacitance	3 pF	0.8 pF
Electrical Output Connector	BNC	BNC
Power Requirements	One 9-volt alkaline battery	One 9-volt alkaline battery
Typical Battery Lifetime	>500 hours	>500 hours





Customer Service

Technical Support

Information and advice about the operation of any New Focus product is available from our applications engineers. For quickest response, ask for “Technical Support” and know the model and serial numbers for your product.

Hours: 8:00–5:00 PST, Monday through Friday (excluding holidays).

Toll Free: 1-866-NUFOCUS (1-866-683-6287)
(from the USA & Canada only)

Phone: (408) 284-6808

Support is also available by fax and email:

Fax: (408) 980-8883

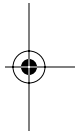
Email: techsupport@newfocus.com

We typically respond to faxes and email within one business day.

Service

In the event that your photodetector malfunctions or becomes damaged, please contact New Focus for a return authorization number and instructions on shipping the unit back for evaluation and repair.





20 • Customer Service

NEW FOCUS, Inc.

