

Multiple Beam Interference

MB-1) We found for multiple beam interference and no surface absorption, the coefficient of reflectance and transmittance are given by

$$\frac{I(r)}{I(i)} = \frac{4R \sin^2 \delta/2}{(1-R)^2 + 4R \sin^2 \delta/2} = \frac{F \sin^2 \delta/2}{1 + F \sin^2 \delta/2}$$

$$\frac{I(t)}{I(i)} = \frac{T^2}{(1-R)^2 + 4R \sin^2 \delta/2} = \frac{1}{1 + F \sin^2 \delta/2}$$

How does the coefficient of reflectance change if the first reflected beam is suppressed?

MB-2) The Airy formulas given above for multiple beam interference are for the situation where both surfaces have an intensity reflectance R . What are the formulas for reflectance and transmittance if the first surface has an intensity reflectance R_1 and the second surface has an intensity reflectance R_2 ? There is no absorption at either surface.

MB-3) A quarter-wave plate is placed inside a Fabry Perot cavity as shown below. The mirror separation is d . Both mirrors have an intensity reflectance of R and they introduce no phase change upon reflection and no absorption. A laser of wavelength λ is used to illuminate a diffuser placed before the Fabry Perot. Between the diffuser and Fabry Perot we place a polarizer such that the light entering the Fabry Perot is plane polarized at an angle θ with respect to the slow axis of the quarter-wave plate. Find the intensity distribution in the focal plane of the lens following the Fabry Perot. You can assume that the quarter-wave plate transmits 100% of all incident energy. Also, for simplicity assume that over the angles of interest the effective optical thickness of the quarter-wave plate is a constant.

Optics 505 - James C. Wyant (Spring, 2000)

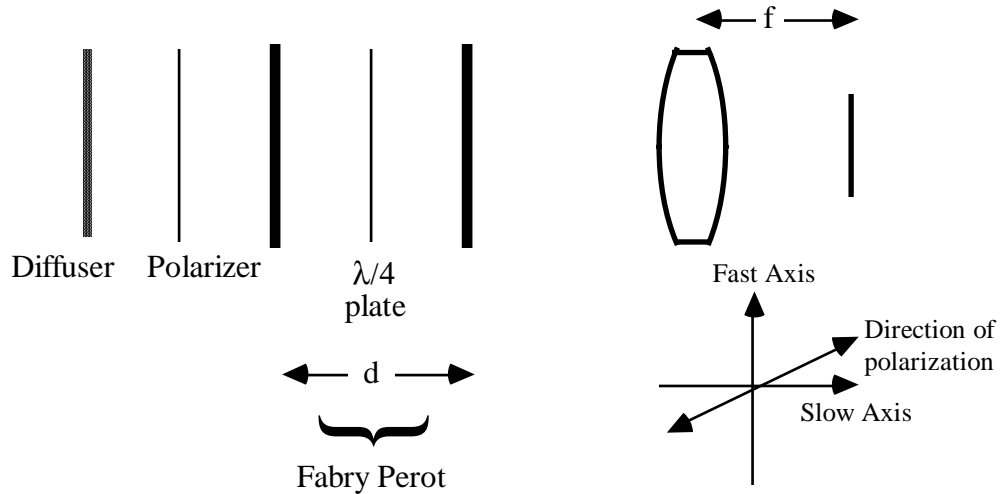

MB-4) The plates of a Fabry Perot etalon are held strictly parallel at a distance of 5 cm. The etalon is placed between two identical converging lenses L_1 and L_2 having a focal length of 15 cm. In the focal plane of L_1 one places a source 1 cm in diameter (centered on the principal focus of L_1). The source emits quasi-monochromatic radiation of wavelength of 500 nm. Take the index of air equal to 1.

- Calculate the interference order at point F' . How many bright fringes can one observe in the focal plane of L_2 ?
- Between the half-silvered plates place an opaque screen which covers half the surface of these plates. How does the screen change the interference fringes observed in the focal plane of L_2 ?
- Replace the opaque screen with a transparent 0.5 mm thick plate of index 1.5. Explain the appearance of the field in the focal plane of L_2 and give the expression for the radii of the bright fringes.
- Using 25 words or less, describe what happens to the fringes if slowly a few seconds of wedge is introduced between the two Fabry Perot mirrors.

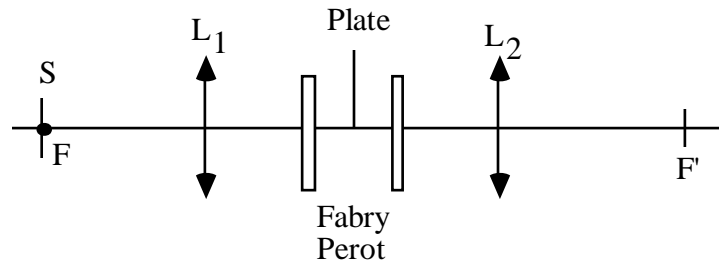

Optics 505 - James C. Wyant (Spring, 2000)

MB-5) The following interferogram is obtained using a FECO interferometer to test a nearly flat mirror.

- a) Does point A correspond to a bump or a hole on the mirror surface?
 - b) What is the approximate surface height difference between point A and point B?
- B?
- c) How would the fringes change if tilt in the x direction, or in the y direction, were introduced between the sample and the reference surface?

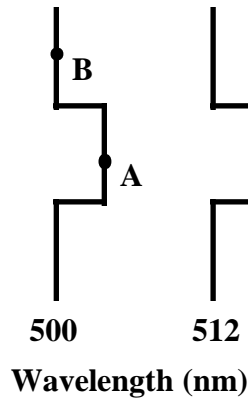

MB-6) A Fabry Perot interferometer is made using two mirrors having 98% reflectivity.

- a) What is the finesse of the interferometer?
- b) Let one of the mirrors be perfectly flat while the other mirror has a surface roughness distribution as shown below. Estimate the finesse of the interferometer. (There are no height errors greater than 0.1 wave, and there is a uniform distribution for errors less than 0.1 wave.)

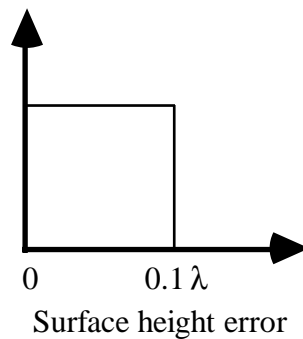

Optics 505 - James C. Wyant (Spring, 2000)

MB-7) a) Show that a film of optical thickness $1/4$ wave and index n_1 will always reduce the reflectance of the substrate on which it is deposited as long as $n_s > n_1 > n_o$. Consider the simplest case of normal incidence and $n_o = 1$.

b) Show that the reflectance of a substrate can be increased by coating it with a $1/4$ wave high index layer i.e., $n_1 > n_s$. Show that the reflected waves interfere constructively. The quarter-wave stack $g(HL)^mHa$ can be thought of as a series of such structures.

c) Determine the refractive index and thickness of a film to be deposited on a glass surface ($n_g = 1.54$) such that no normally incident light of wavelength 540 nm is reflected.

MB-8) Determine the refractive index and thickness of a thin film to be deposited on a glass surface ($n_g = 1.54$) such that no normally incident light of wavelength 633 nm is reflected.

MB-9) A slab of optically homogeneous material of unknown refractive index is illuminated with yellow light (wavelength = 589 nm) from a sodium lamp. The surfaces of the slab are coated with semi-transparent mirrors and the thickness of the slab is 11.78 mm. The focal length F of the lens is 330 mm. A bright spot is at the center of the screen and the diameter of the first bright fringe is 6 mm. What is the refractive index of the material?

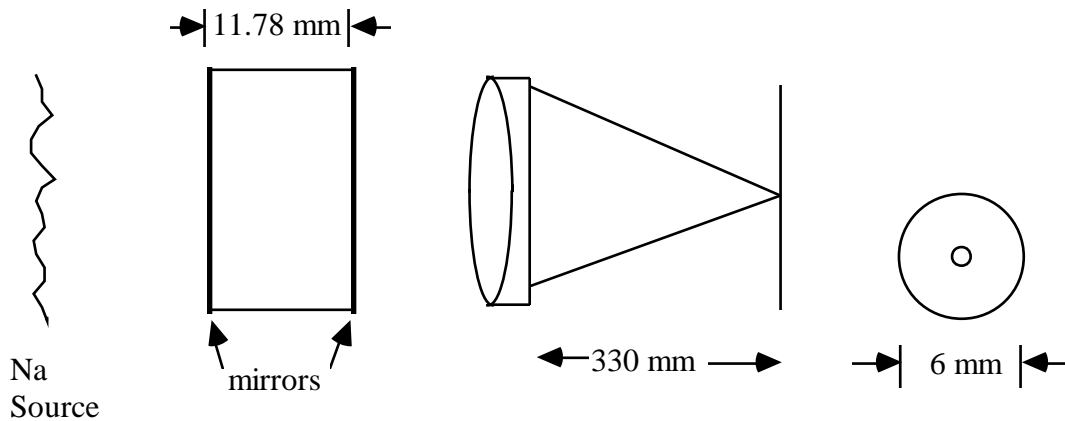

Optics 505 - James C. Wyant (Spring, 2000)

MB-10) The following two fringes were obtained using a FECO to test two flat mirrors.

- a) What is the separation between the two mirrors?
- b) Is a large separation good or bad? Why?

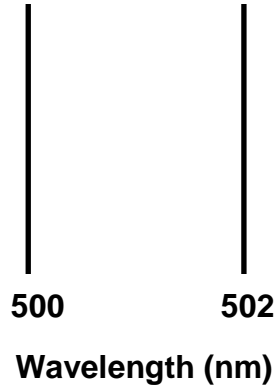

MB-11) Determine the refractive index and thickness of a thin film to be deposited on a glass surface ($n_g = 1.59$) such that no normally incident light of wavelength 633 nm is reflected. If the angle of incidence (incident from air to thin film) changes to 5 degrees, what is the wavelength for minimum reflection?

MB-12) The following two fringes were obtained using a FECO to test two flat mirrors.

- a) What is the order number for the left fringe?
- b) What is the separation between the two mirrors?
- c) What would the fringes look like if one of the mirrors had a 250 nm high spot in the center?
- d) How would the fringe spacing change if the mirror separation were doubled?

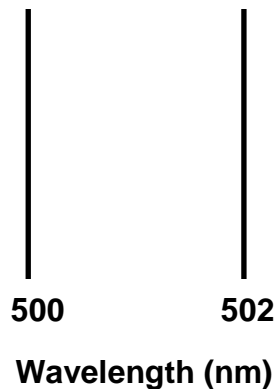

Optics 505 - James C. Wyant (Spring, 2000)

MB-13) A Fabry Perot interferometer is made using two mirrors having nearly 100 % reflectivity. While one of the mirrors is very flat, the other mirror has the surface roughness distribution shown below. The finesse of the fringes is measured to be 10. What is the maximum surface height error (shown as x in the figure) in units of the wavelength of light used in the interferometer?

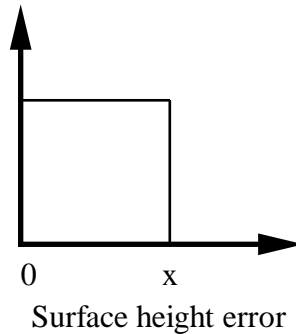

MB-14) I am using a FECO interferometer to measure the surface roughness of a bare piece of glass.

- Sketch the interferometer.
- What must I do to the bare piece of glass before the test?
- Sketch the fringes one would obtain if we are observing a nearly flat surface with a small bump. Carefully label the x and y axes of the plot.

MB-15) A film of optical thickness $1/4$ wave and index n_1 is placed on a substrate of index n_s . The film is used at normal incidence in air. Give a relationship between n_1 and n_s that will always cause the film to reduce the reflectivity? Explain.

MB-16) The so-called characteristic matrix was found to be very useful in analyzing multilayer films.

- How many elements are in the characteristic matrix?
- What does the characteristic matrix relate?
- What boundary conditions were used in deriving the characteristic matrix?
- Let us use the characteristic matrix to design an AR coating for wavelength λ_1 at normal incidence. Will the wavelength for minimum reflectance increase or decrease if the angle of incidence is changed to 5 degrees?

Optics 505 - James C. Wyant (Spring, 2000)

MB-17) I am using a FECO interferometer to measure the surface of a highly reflecting piece of glass. The glass surface is flat except for a small area 200 nm high bump in the middle of the sample. Neglect any phase change upon reflection.

- a) The wedge between the sample and the reference is minimized and the separation between the flat portion of the sample and the reference surface is 2000 nm. Neglecting any phase change upon reflection, sketch the fringes for fringe order 8, 9, and 10. Carefully label the x and y axes of the plot.
- b) Repeat part a for the case where 2 fringes of tilt are introduced between the sample and reference and the tilt is along the long direction of the slit in the FECO interferometer. The average separation between the sample and reference is kept at 2000 nm.
- c) Repeat part b for the case where the tilt is perpendicular to the long direction of the slit.

MB-18) The following interferogram is obtained using a FECO interferometer to test a 5 cm x 5 cm square flat mirror.

- a) Sketch the interferometer.
- b) For point A, what is the separation between the sample being measured and the reference surface?
- c) What is the wedge angle between the sample being measured and the reference surface?

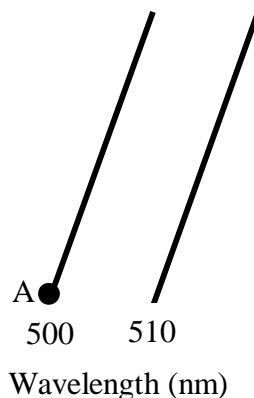

State any assumptions you are making.