

Homework #2:

Problem 1

Determine the focal length of a $\frac{1}{4}$ " diameter lens using reciprocal magnification. The track length is set to 150 mm using a machinist scale. The lens is moved 57.9 mm between position 1, where the magnification is -2.35 and position 2 where the magnification is -0.45. What is the focal length of the lens? What is the distance between the principal planes?

The setup used two reticles (same part number and manufacturer) with 0.1 mm divisions are used in the setup, one as the object and the other in a 10x microscope to view the image and measure magnification. The microscope has a 10x eyepiece. The object to image spacing and lens motion were measured with a ruler.

List the sources of focal length measurement uncertainty in this setup.

Extra / graduate required

For each source of measurement uncertainty that was listed: estimate the uncertainty, provide a reason for the estimated value, and describe how you could reduce the estimated uncertainty by a factor of two or more.

Problem 2

A Cassegrain telescope is to be used as a compact decollimator (collimator used backwards) to focus light for a red HeNe laser. Input the design into the lens design program of choice. The prescription data is from Zemax. A conic of -1 is a parabola. Units are mm. The primary is the aperture stop, the secondary is an obscuration so add a surface for it, and the primary has a hole in it. The focal length of the system is 300 mm.

SURFACE DATA SUMMARY:

Surf	Type	Radius	Thickness	Glass	Diameter	Conic	Comment
OBJ	STANDARD	Infinity	Infinity		0	0	
1	STANDARD	Infinity	50		200.0524	0	Dummy
2	STANDARD	Infinity	100		200.0349	0	Obscuration
STO	STANDARD	-300	-100	MIRROR	200	-1	Primary
4	STANDARD	-200	100	MIRROR	70.8	-9	Secondary
IMA	STANDARD	Infinity			0.1138008	0	

SURFACE DATA DETAIL:

Surface OBJ : STANDARD
Surface 1 : STANDARD Dummy
Surface 2 : STANDARD Obscuration
Aperture : Circular Obscuration
Minimum Radius : 0
Maximum Radius : 35.4
Surface STO : STANDARD Primary
Mirror Substrate : Curved, Thickness = 4.00000E+000
Aperture : Floating Aperture
Maximum Radius : 100
Surface 4 : STANDARD Secondary
Mirror Substrate : Curved, Thickness = 1.41600E+000
Aperture : Floating Aperture
Maximum Radius : 35.4
Surface IMA : STANDARD

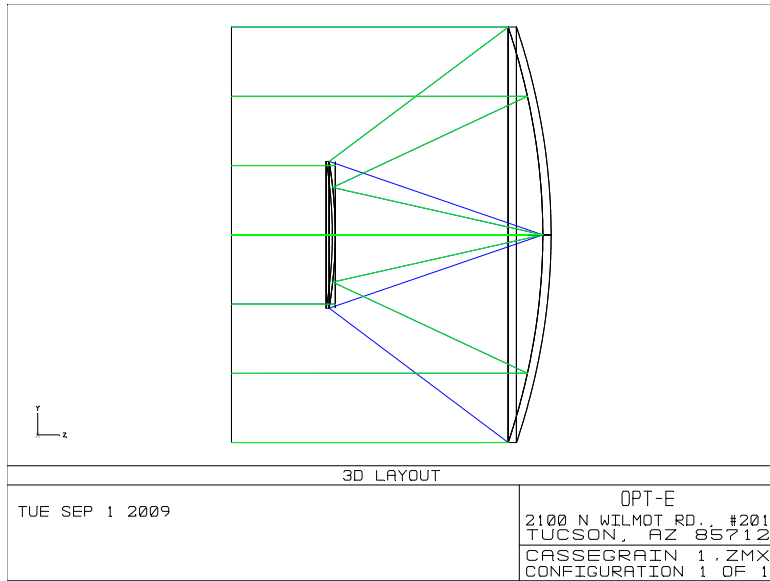

Figure 1 Layout

Produce an easy to read table with the following information. The ability for your program manager (teaching assistant) to easily interpret the information you present is as important in practice as the answers.

- What is the Strehl ratio of the nominal design? How much image plane shift is necessary to reduce the Strehl ratio to 0.8 and 0.5? Show spot diagrams with the Airy disk size indicated on the graph for the three configurations (nominal design, and two displaced).
- How far off-axis can the incoming light be and maintain a Strehl ratio of 0.8? peak-to-valley wavefront error of $\frac{1}{2}$ wave relative to the centroid? RMS wavefront $\frac{1}{10}$ wave relative to the centroid?
- Manually determine alignment sensitivity (not a Monte Carlo analysis) by translating the secondary mirror to produce $\frac{1}{2}$ PV error. How much translation is required? Repeat for tilt of the secondary. Measure the wavefront error relative to the centroid.
- In all cases **look** at spot diagrams, FFT PSF surface / image / cross section, MTF curves, distortion curves and a few other things so that you know where to find them. Do this for different misaligned conditions.

Problem 3

The Cassegrain telescope above is comprised of two conic mirrors: a paraboloid and a hyperboloid (often called a parabola and hyperbola). A parabola perfectly focuses collimated light. A hyperbola has two foci, one on each side of the mirror. A parabola can be tested in autocollimation against a flat.

- a) Setup an autocollimation test of the parabola from the previous problem in a lens design program starting with the object at the focus of the parabola. The order of the surfaces should be object \rightarrow parabola \rightarrow flat \rightarrow parabola \rightarrow image. Provide the prescription in a format similar to the one provided above for the telescope (make it easy to read) and a layout diagram of the system.
- b) A hyperbola differs from a parabola in that both points are at a finite distance, rather than one being at infinity. The two foci of a hyperbola are on opposite sides of the hyperbola. A parabola uses a flat mirror in an autostigmatic (autocollimation) test setup. A hyperbola would use a sphere in place of the flat mirror in an autostigmatic test setup. Provide a prescription and layout diagram for the setup. What is this test setup called? Where are the two foci of the hyperbola relative to the vertex of the hyperbola?

extra credit / graduate required (c)

- c) An ellipse has two foci like a hyperbola, but they are both on the same side of the mirror. Redesign the telescope replacing the convex hyperbola with a concave ellipse. The spacing between the primary and secondary should be 170 mm. Show a prescription and layout. Design an autostigmatic imaging setup for the ellipse and provide its prescription and layout. What kind of telescope is this? This telescope design is longer than a Cassegrain, why would someone build this kind of telescope? What is the Strehl ratio of your design? Where are the two foci of the ellipse relative to its vertex?