

# Chapter 4

---

## **4. Basic Interferometry and Optical Testing**

**4.1 Two-Beam Interference**

**4.2 Fizeau Interferometer**

**4.3 Twyman-Green Interferometer**

**4.4 Laser-Based Fizeau Interferometer**

**4.5 Mach-Zehnder Interferometer**

**4.6 Typical Interferograms**

**4.7 Interferograms and Moiré Patterns**

**4.8 Classical techniques for getting data into the computer**

# Two-Beam Interference Fringes

$$I = I_1 + I_2 + 2\sqrt{I_1 I_2} \cos(\alpha_1 - \alpha_2)$$

$\alpha_1 - \alpha_2$  is the phase difference between the two interfering beams

$$\alpha_1 - \alpha_2 = \left(\frac{2\pi}{\lambda}\right)(\text{optical path difference})$$

# Sinusoidal Interference Fringes

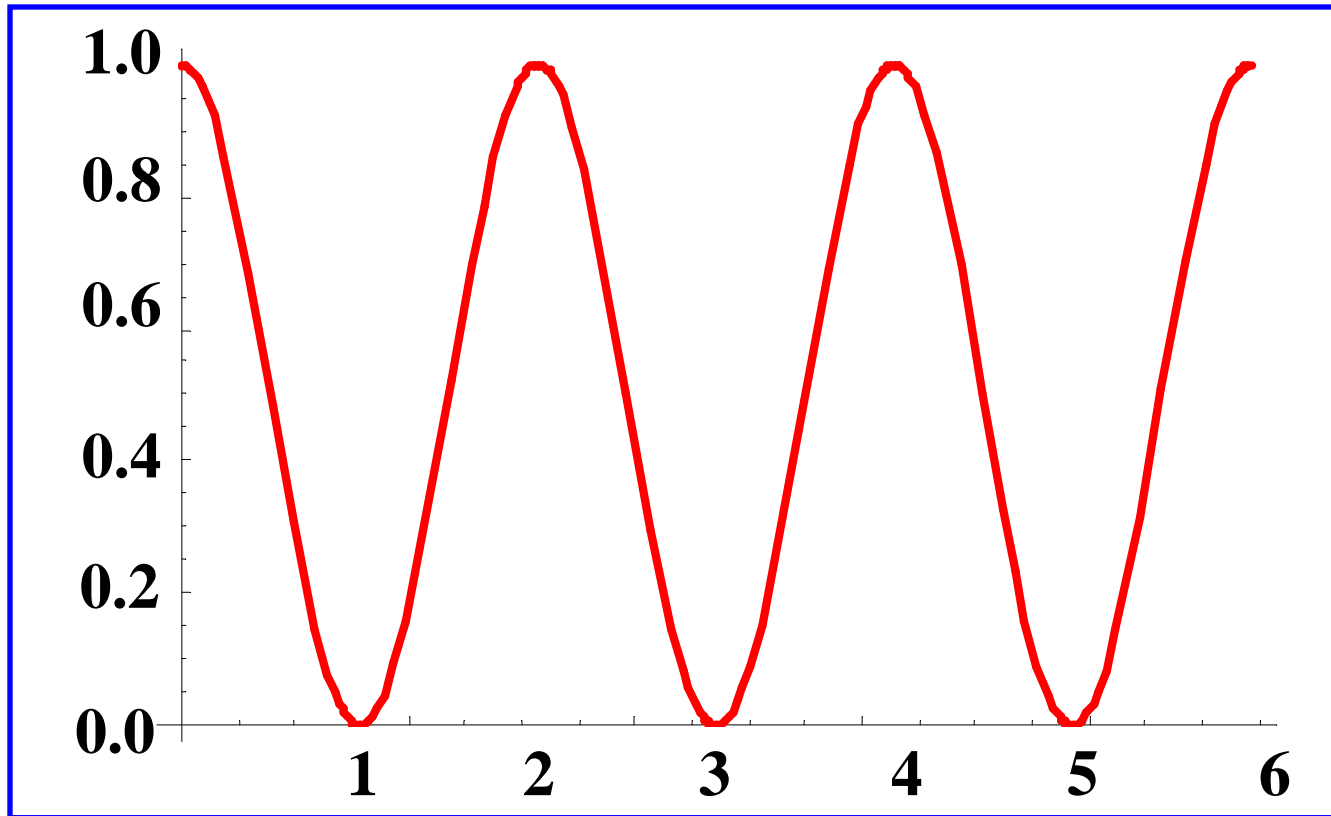

$$I = I_1 + I_2 + 2\sqrt{I_1 I_2} \cos(\alpha_1 - \alpha_2)$$

# Classical Fizeau Interferometer

Some use Fizeau fringes to imply a relatively large air gap (mm instead of a few wavelengths)

1864

See Opt. Shop Test., Ch 1 - Newton interferometer. An extended, quasi-monochromatic source is used to produce fringes of equal thickness.

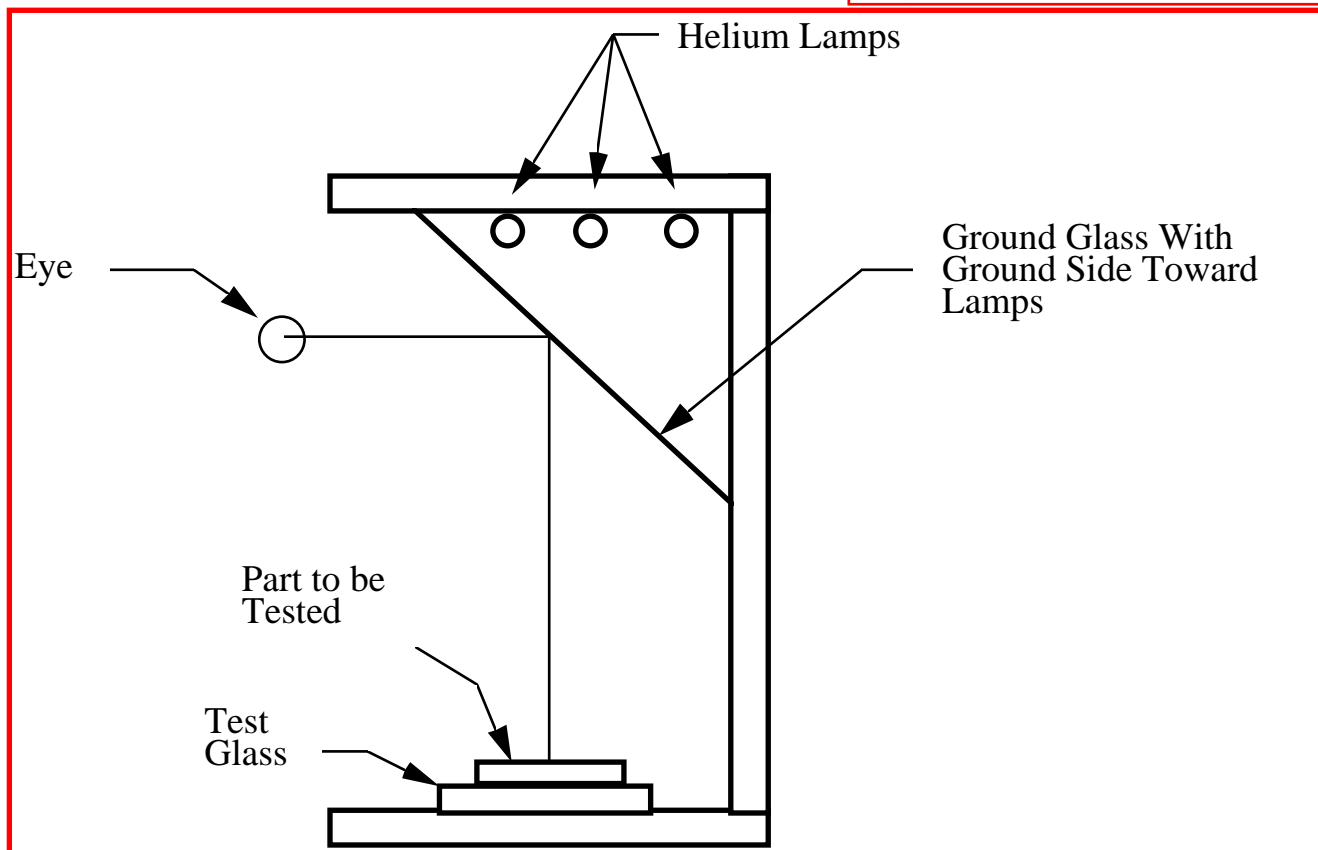

Should be focused at infinity, otherwise introduce a bias in OPD

# Typical Interferogram Obtained using Fizeau Interferometer

---

Fringes are contours of constant OPD.  
Read them like a topographic map.  
What is the height interval between contour lines?

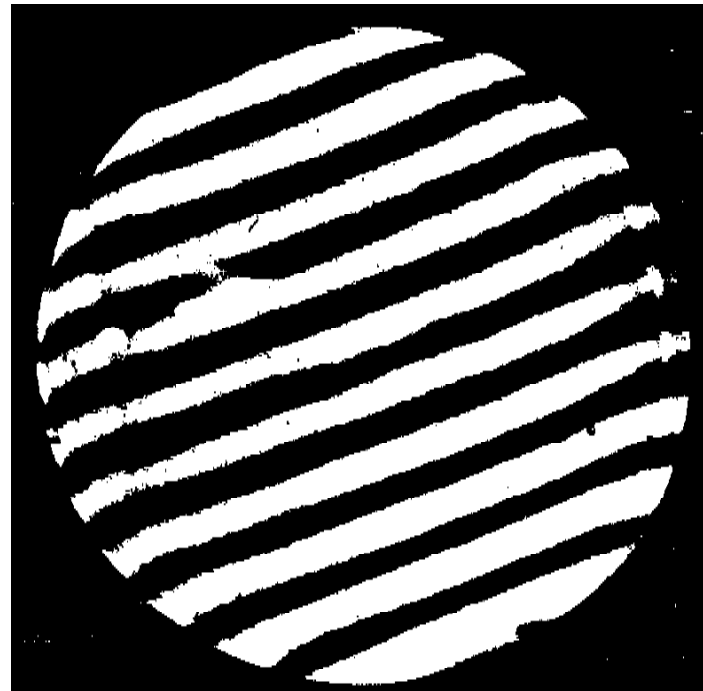

# Relationship between Surface Height Error and Fringe Deviation

Fringes - curved lines  
S - average spacing of fringes  
 $\Delta$  - fringe displacement from average

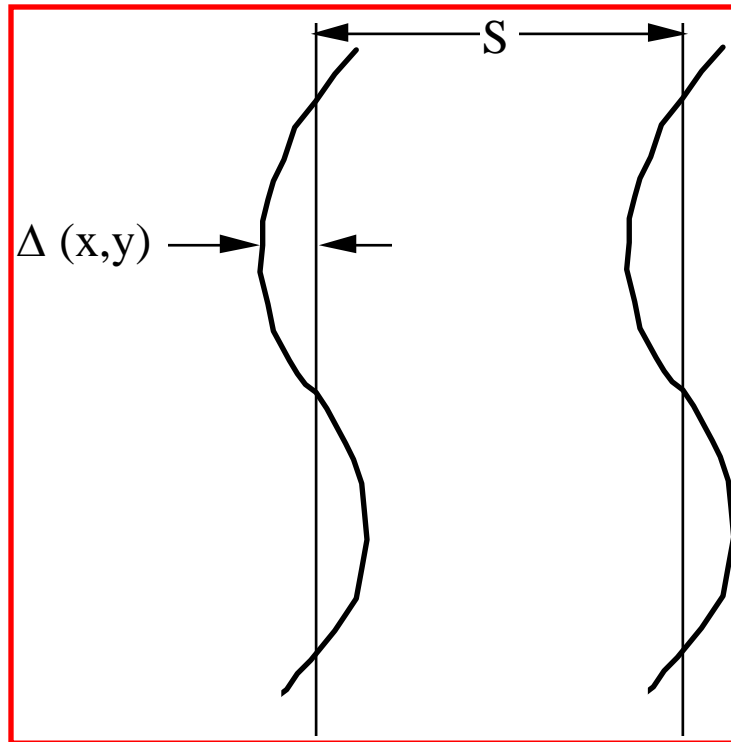

$$\text{Surface height error} = \left(\frac{\lambda}{2}\right)\left(\frac{\Delta}{S}\right)$$

# Fizeau Fringes

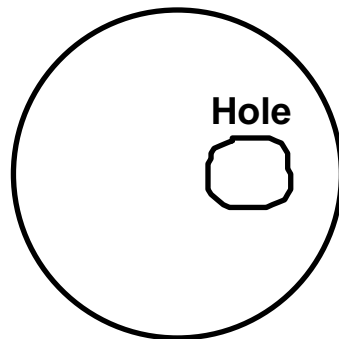

Top View

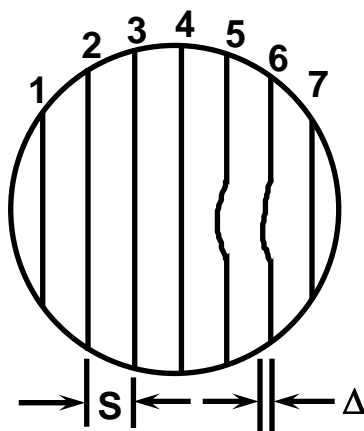
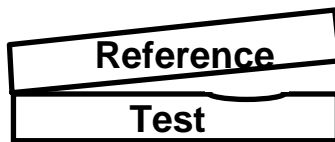

Interferogram

2007 - James C. Wyant

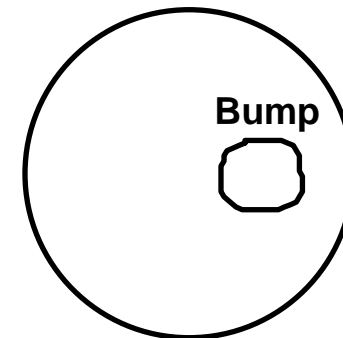

Top View

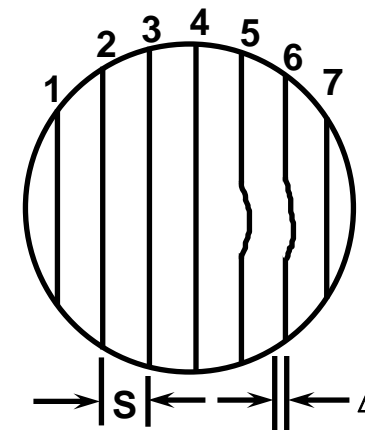
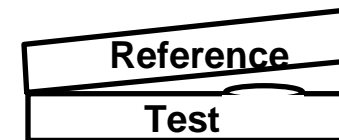

Interferogram

Chapter 4 Page 7 of 29

**For a given fringe the separation between the two surfaces is a constant.**

$$\text{Height error} = (\lambda/2)(\Delta/S)$$

Fringes bend so that change in thickness of wedge plus error in part is constant since a fringe (light or dark) represents a constant OPD.

Can fringes cross?

# Fizeau Fringes for Concave and Convex Surfaces

---

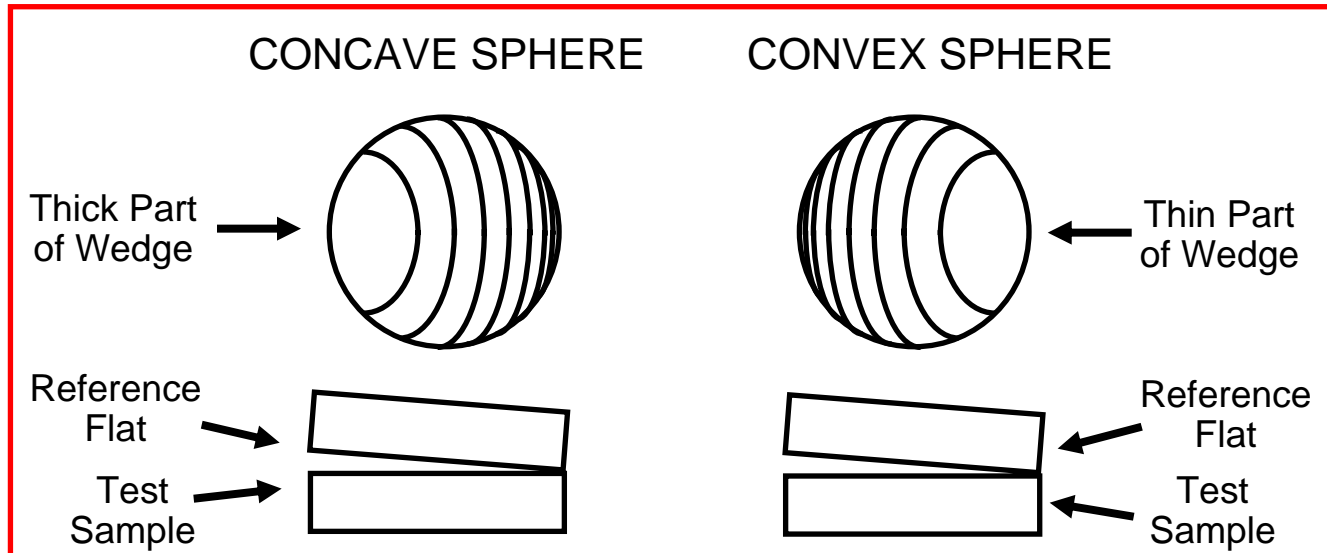

# Twyman-Green Interferometer (Flat Surfaces)

1918

T-G uses a monochromatic point source that is collimated, while a Michelson uses an extended source.

Both types in general require a compensating plate if used with a gas discharge lamp.

The coherence length of a laser makes T-G much more useful.

The coherence length of a laser makes stray light problematic - scatter from dust / scratches / edges / etc.

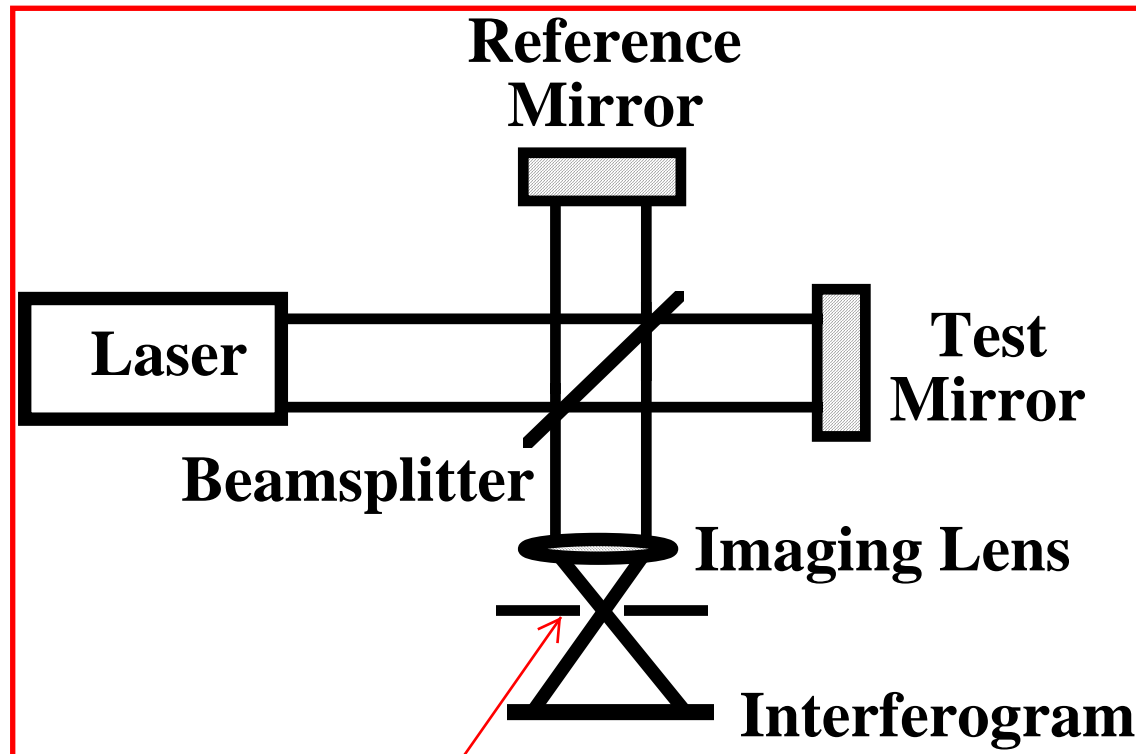

What happens if no imaging lens is present?

Spatial filter to reduce stray reflections, does it affect MTF of instrument?

# Use of Rotating Ground Glass to Limit Spatial Coherence of Source

Using a **ground glass diffuser** in an interferometer is useful for destroying spatial coherence. Ground glass is often used to limit the spatial coherence of the source. Coherence is a requirement to obtain interference fringes, but spurious fringes due to stray reflections are a dominant noise source. A laser is focused onto a rotating ground glass diffuser to decrease the spatial coherence and render stray reflections incoherent with the test and reference beams. A stationary diffuser creates a stationary speckle pattern, so the ground glass must be rotated so the speckle pattern changes much faster than the camera integration cycle. Each scatter site on the ground glass has a random phase. Integrated over time, the phase distribution at each location becomes uniform.



# Use of Rotating Ground Glass in Imaging Optics

In order to increase the flexibility of commercial laser-based Fizeau interferometers, a zoom lens can be used to adjust for varying test part sizes. A multi-element zoom lens creates many stray reflections, which cause spurious fringes in the recorded interferogram. Imaging the interferogram onto ground glass before the zoom lens converts the two coherent waves into an incoherent irradiance signal that is imaged to the camera via the zoom lens. Any stray reflections within the zoom lens are incoherent; they add in irradiance and do not cause phase errors. Ground glass scatters light, causing a large amount of loss in the system. A second drawback is that the motor that rotates the ground glass inevitably introduces vibrations, another major noise source in interferometers.

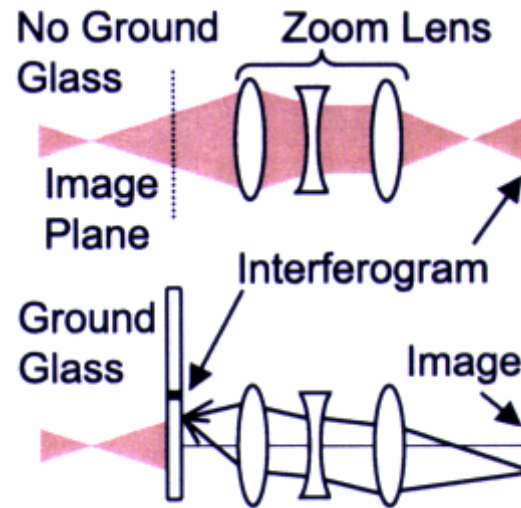

# Twyman-Green Interferometer (Spherical Surfaces)

Unequal path between test and reference requires significant coherence length (temporal coherence).

Reflectivity of reference mirror can be selected to match test mirror to maximize fringe contrast.

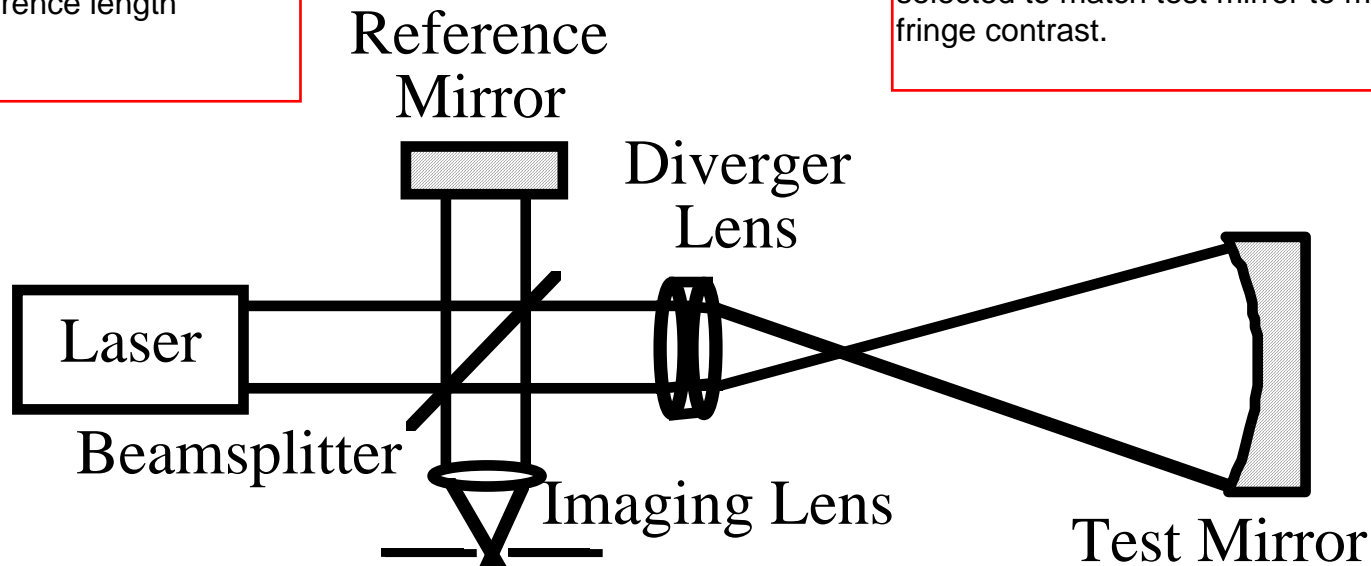

Changes in OPL (optical path length) of reference and test arms affects fringe stability and measurement quality.

Interferogram

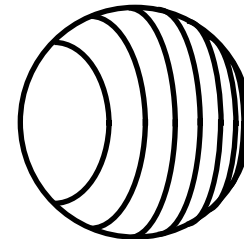

Incorrect Spacing

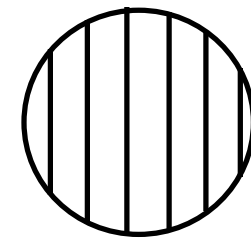

Correct Spacing

# Typical Interferogram

---

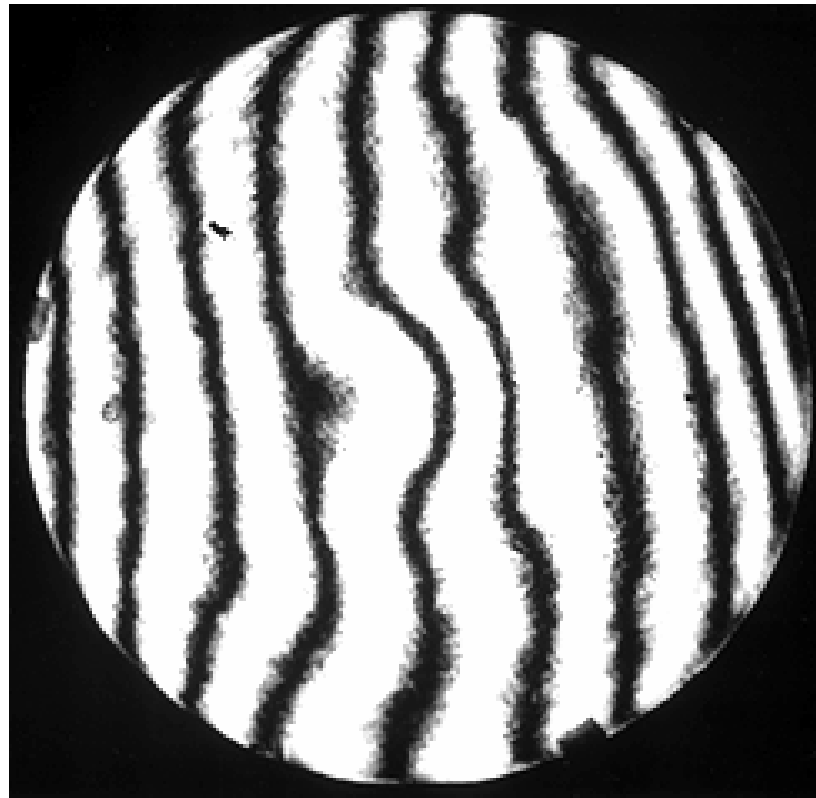

# Fizeau Interferometer-Laser Source (Flat Surfaces)

---

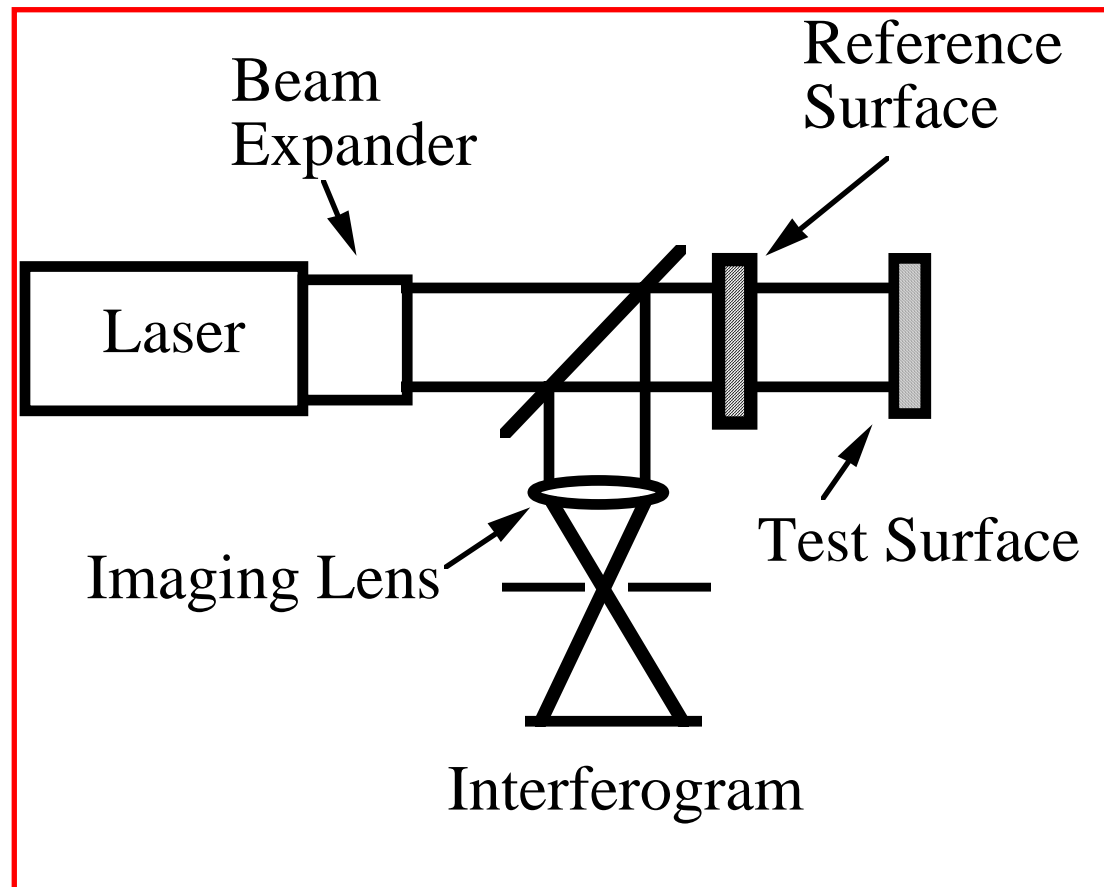

Fizeau is mostly common path for imaging and wavefront. What are benefits of this?

How about matching reflectivity?

Quality of optical surfaces of TG vs. Fizeau?

# Fizeau Interferometer-Laser Source (Spherical Surfaces)

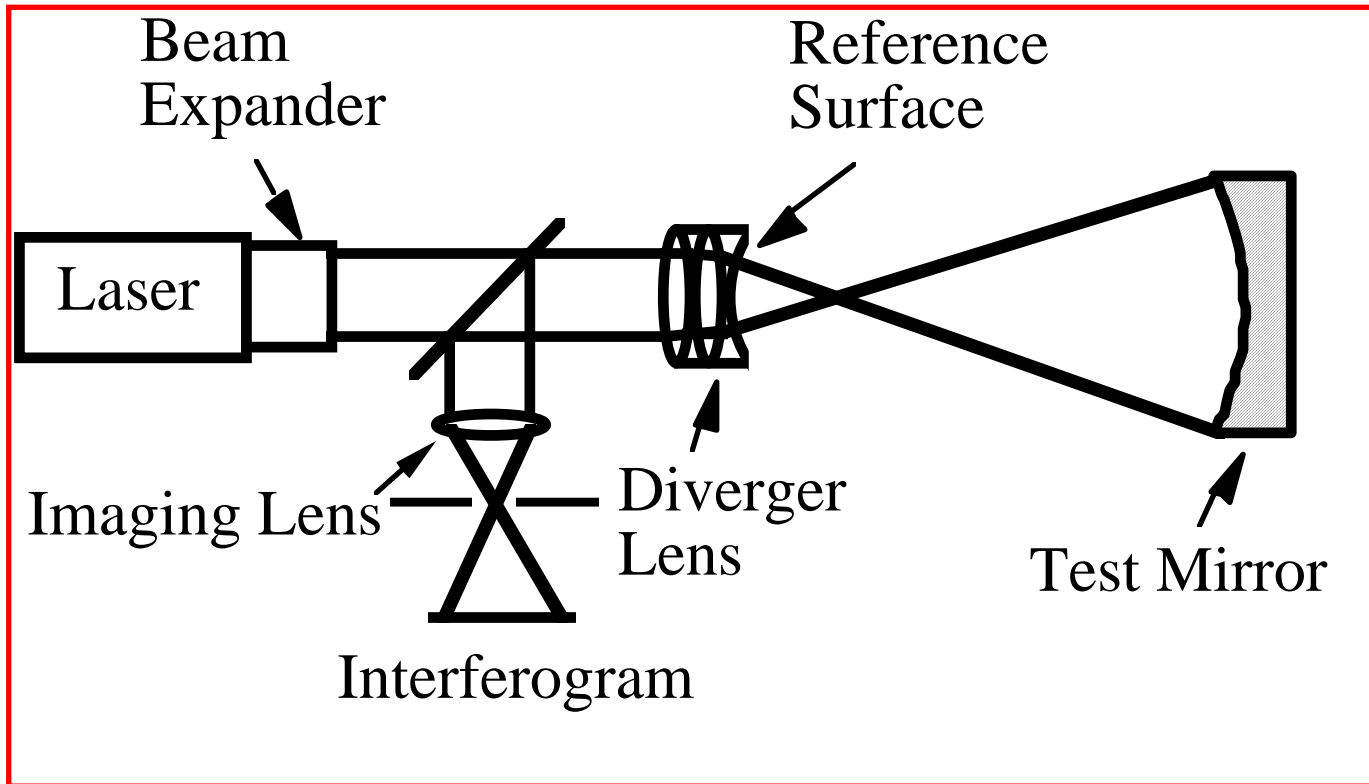

An optical system always images an object to an image and the entrance pupil to the exit pupil.

Actually, every object plane is imaged to its corresponding image plane.

An interferometer is an optical system, so what two sets of planes form conjugate pairs?

1. Wavefront or source to center-of-curvature of test optic.
2. Test optic to detector

What happens if test object is not imaged onto the detector?

# Testing High Reflectivity Surfaces

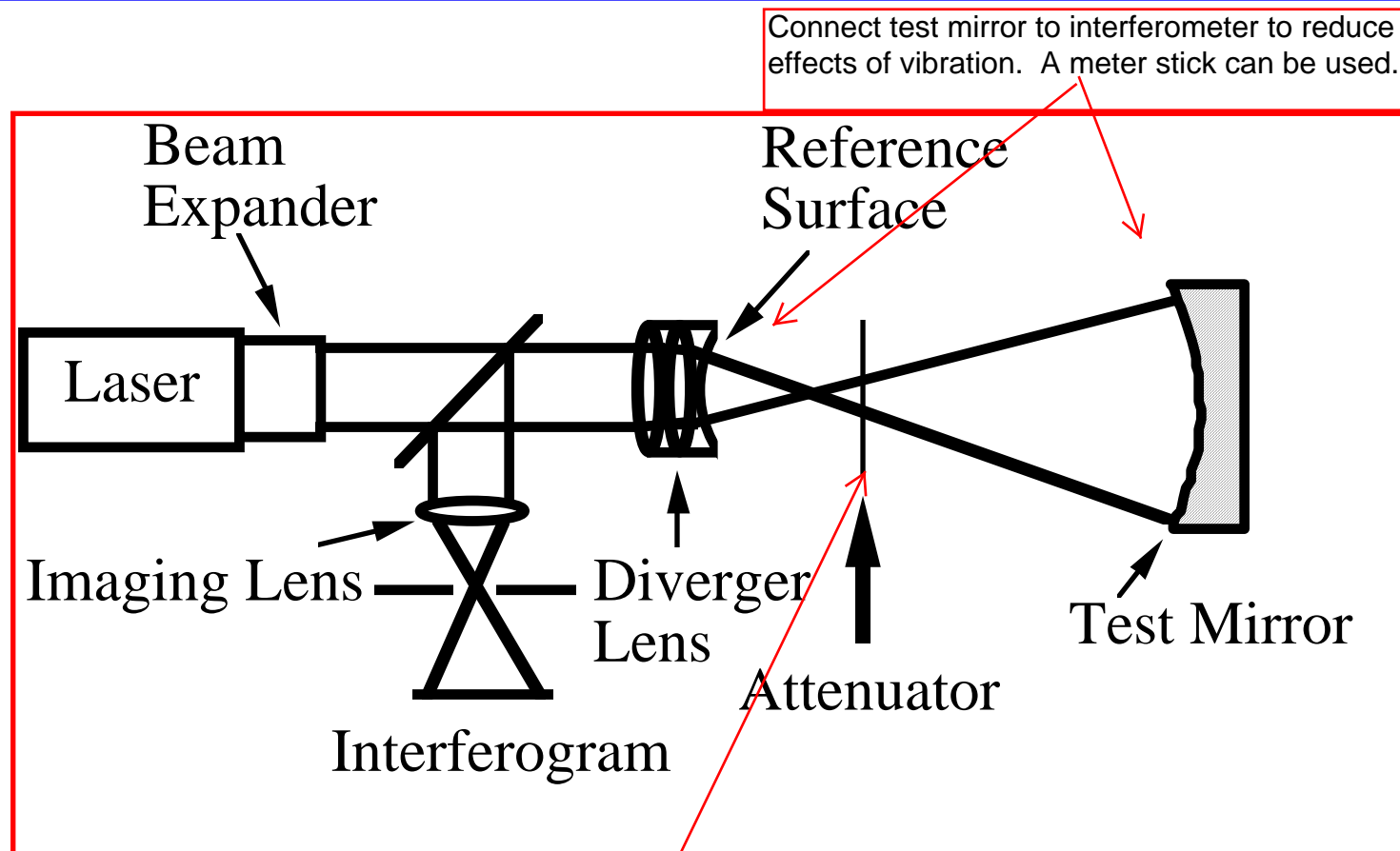

Connect test mirror to interferometer to reduce effects of vibration. A meter stick can be used.

Should attenuator be normal to beam, even a diverging beam?

Attenuator is often a partially reflecting pellicle beam splitter, which is a fragile, thin piece of mylar. (Never touch it.)  
What is the advantage of using a pellicle beam splitter vs. a plate or cube? Disadvantage?

# Hill or Valley?

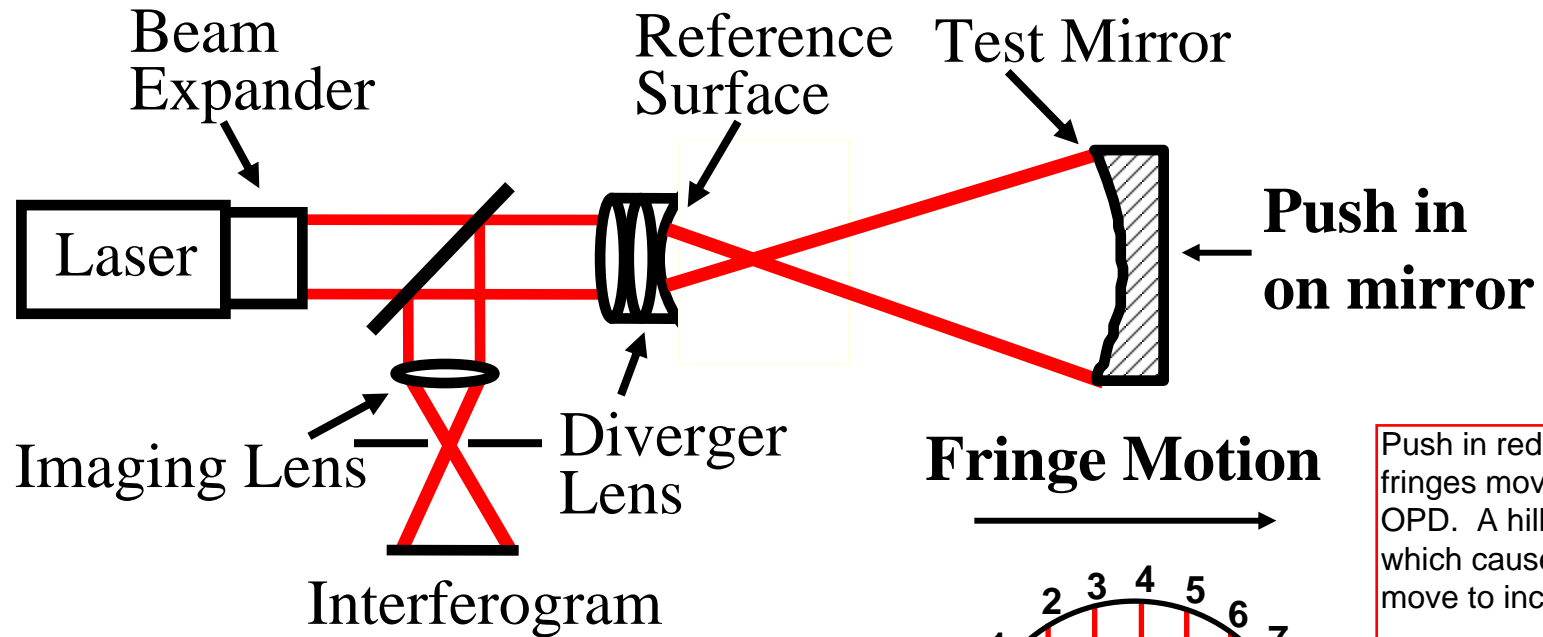

## Fringe Motion

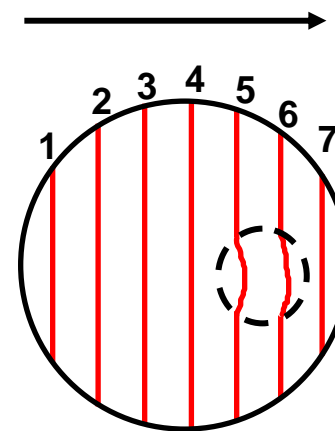

Push in reduces OPD so fringes move to increase OPD. A hill reduces OPD which causes fringes to move to increasing OPD.

**Hill**

Interferogram

# Mach-Zehnder Interferometer

---

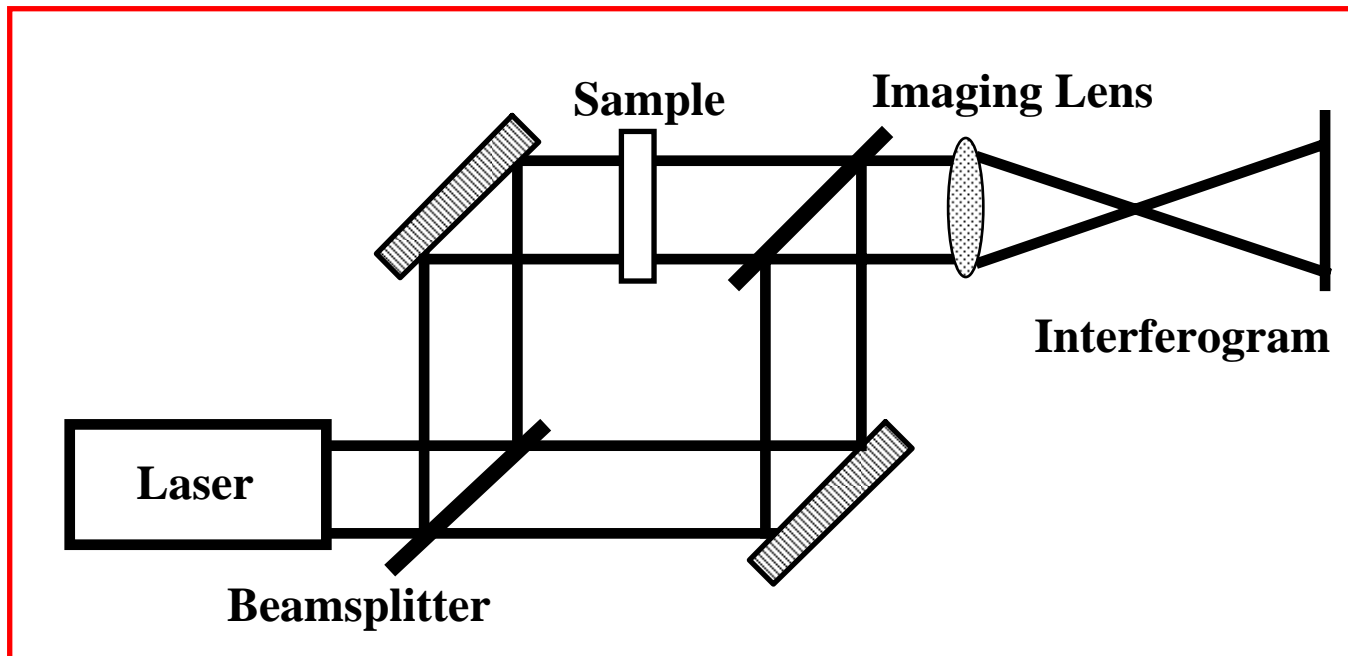

**Testing samples in transmission**

# Laser Beam Wavefront Measurement

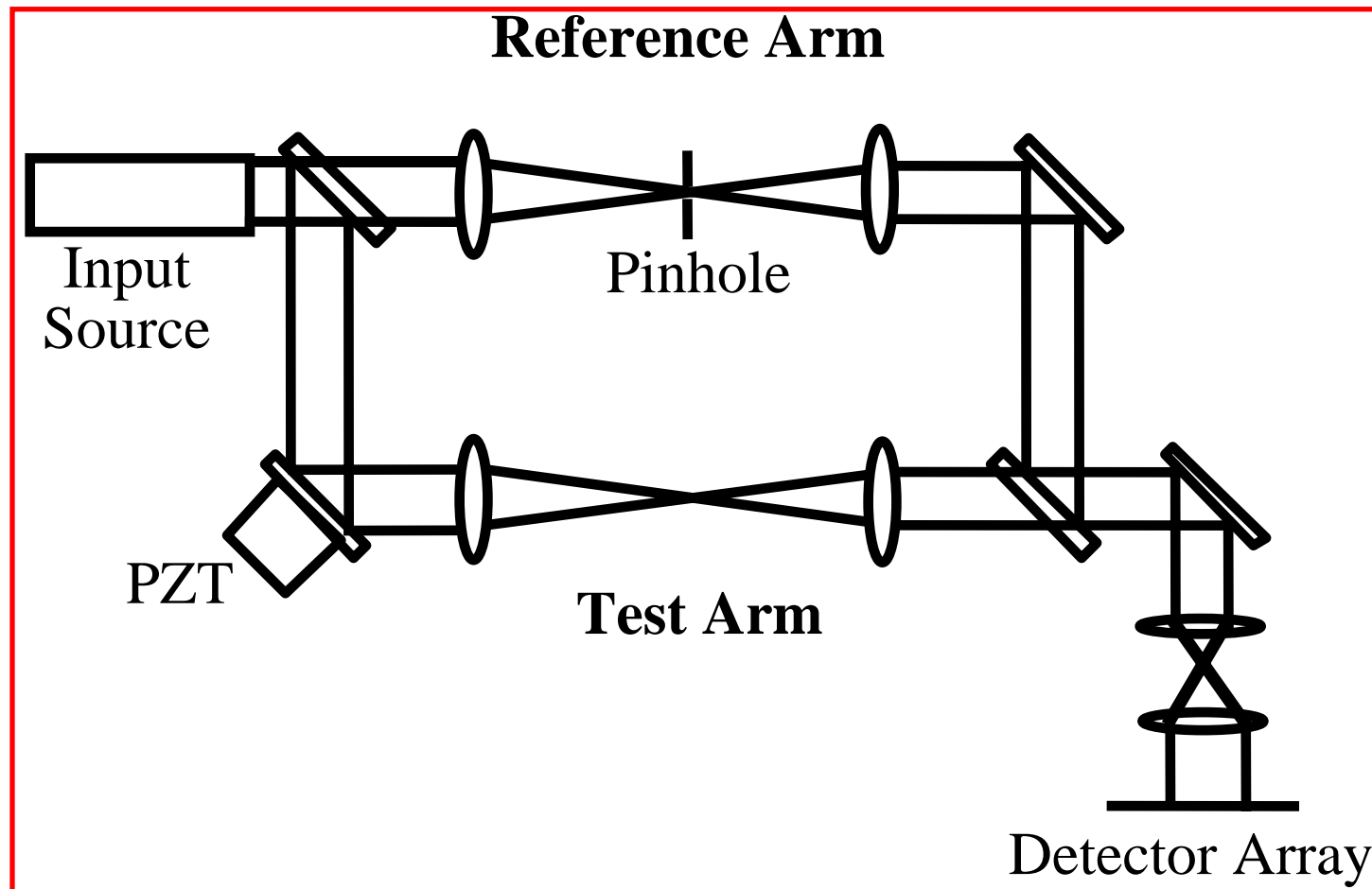

# Interferograms, Spherical Aberration

Curved fringes are tangent to the average fringe pattern around the axis

Paraxial Focus

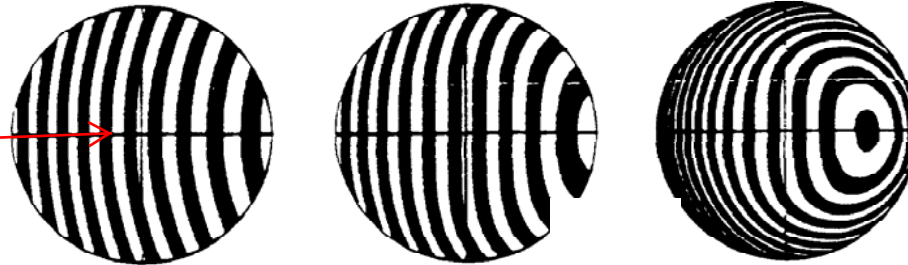

Curved fringes are tangent to the average fringe pattern midway out to the edge.

Mid Focus



Curved fringes are tangent to the average fringe pattern at edge of pupil

Marginal Focus

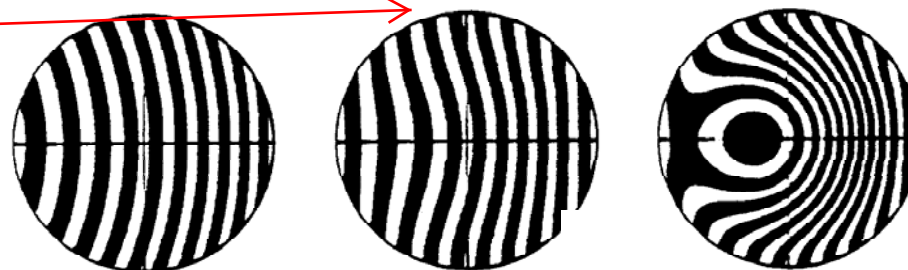

No Aberration  
Focal Shift

Small Spherical  
Aberration

Larger Spherical  
Aberration

# Interferograms

## Small Astigmatism, Sagittal Focus

---

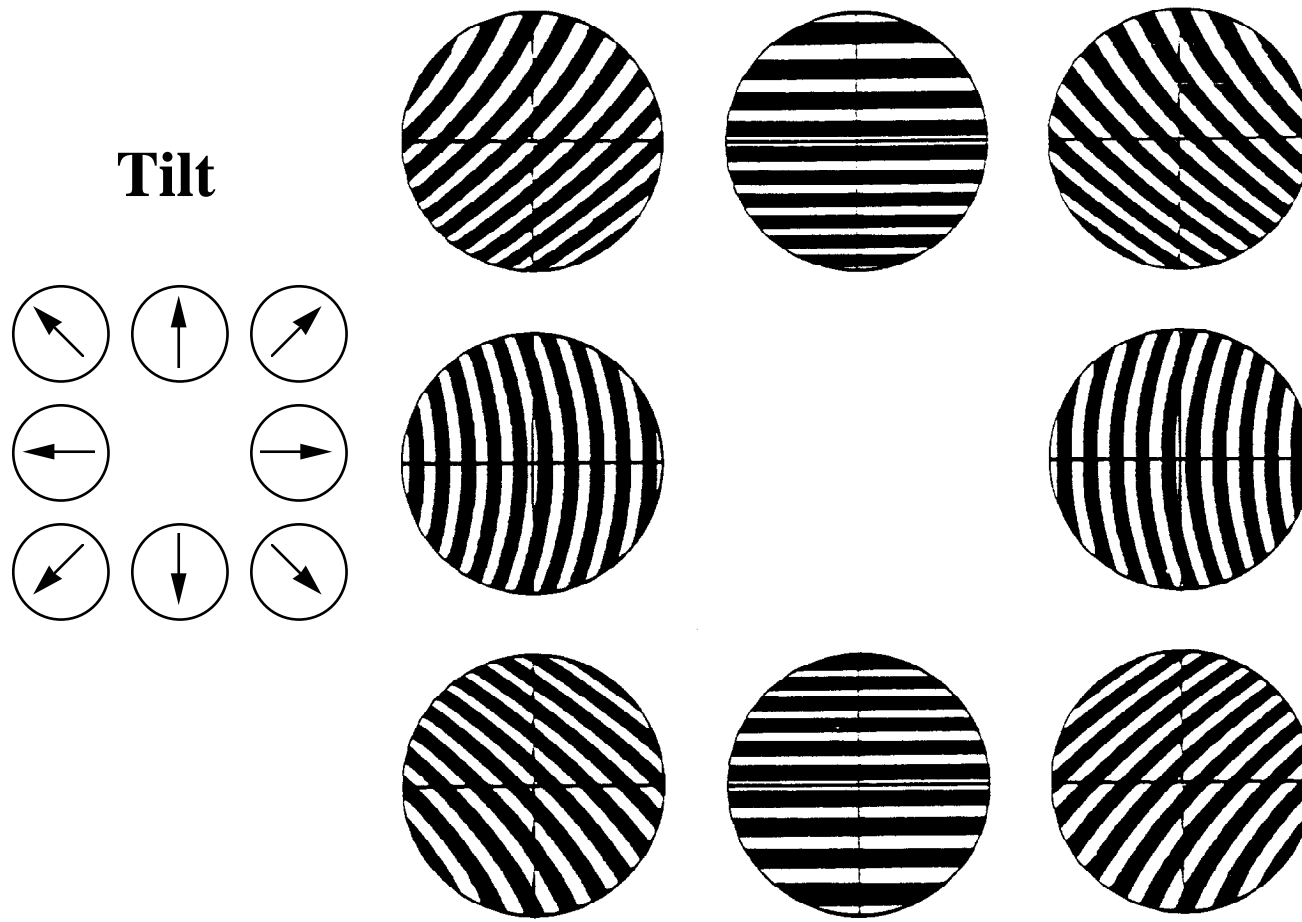

# Interferograms

## Small Astigmatism, Medial Focus

---

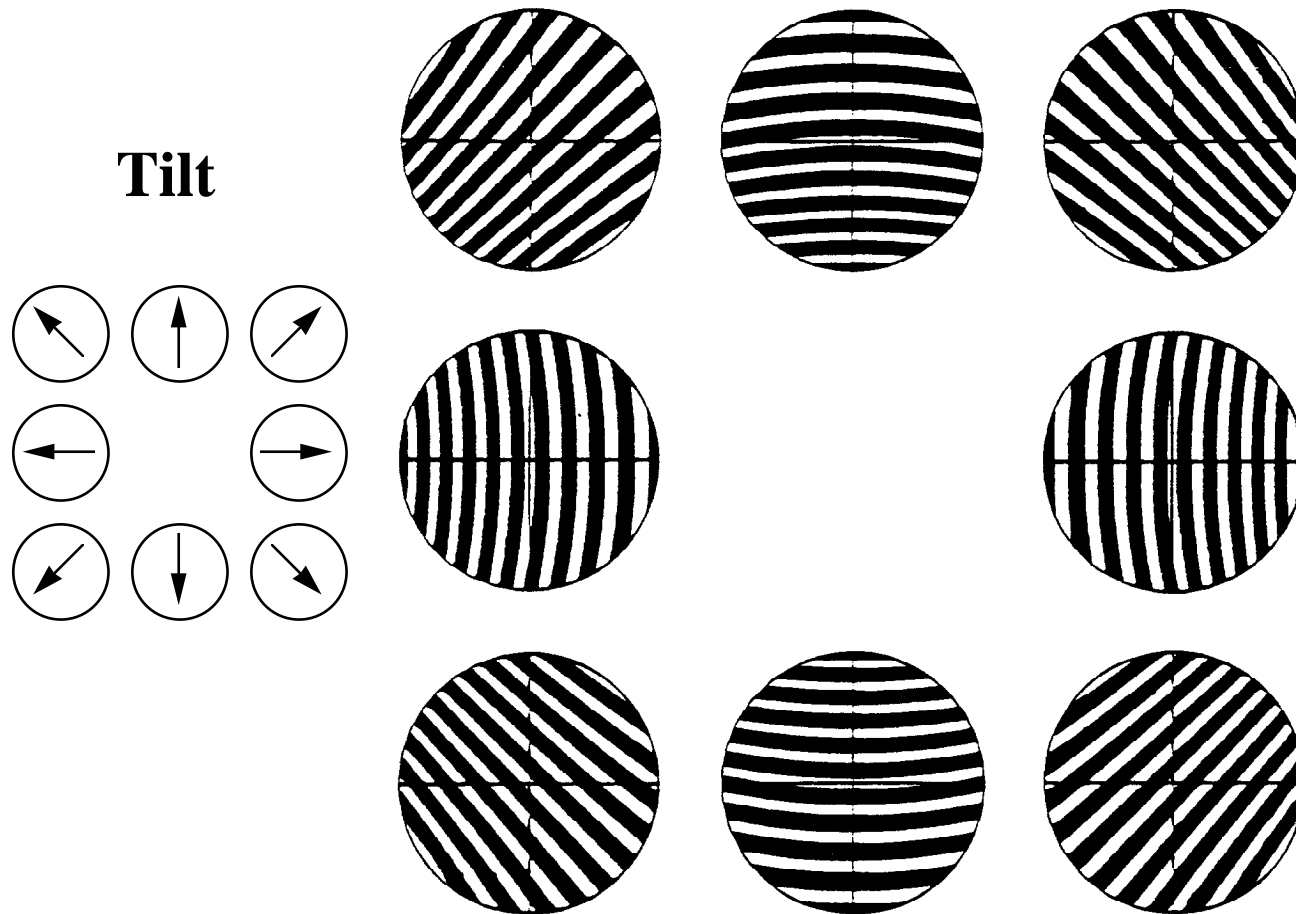

# Interferograms, Large Astigmatism, Sagittal Focus, Small Tilt

---

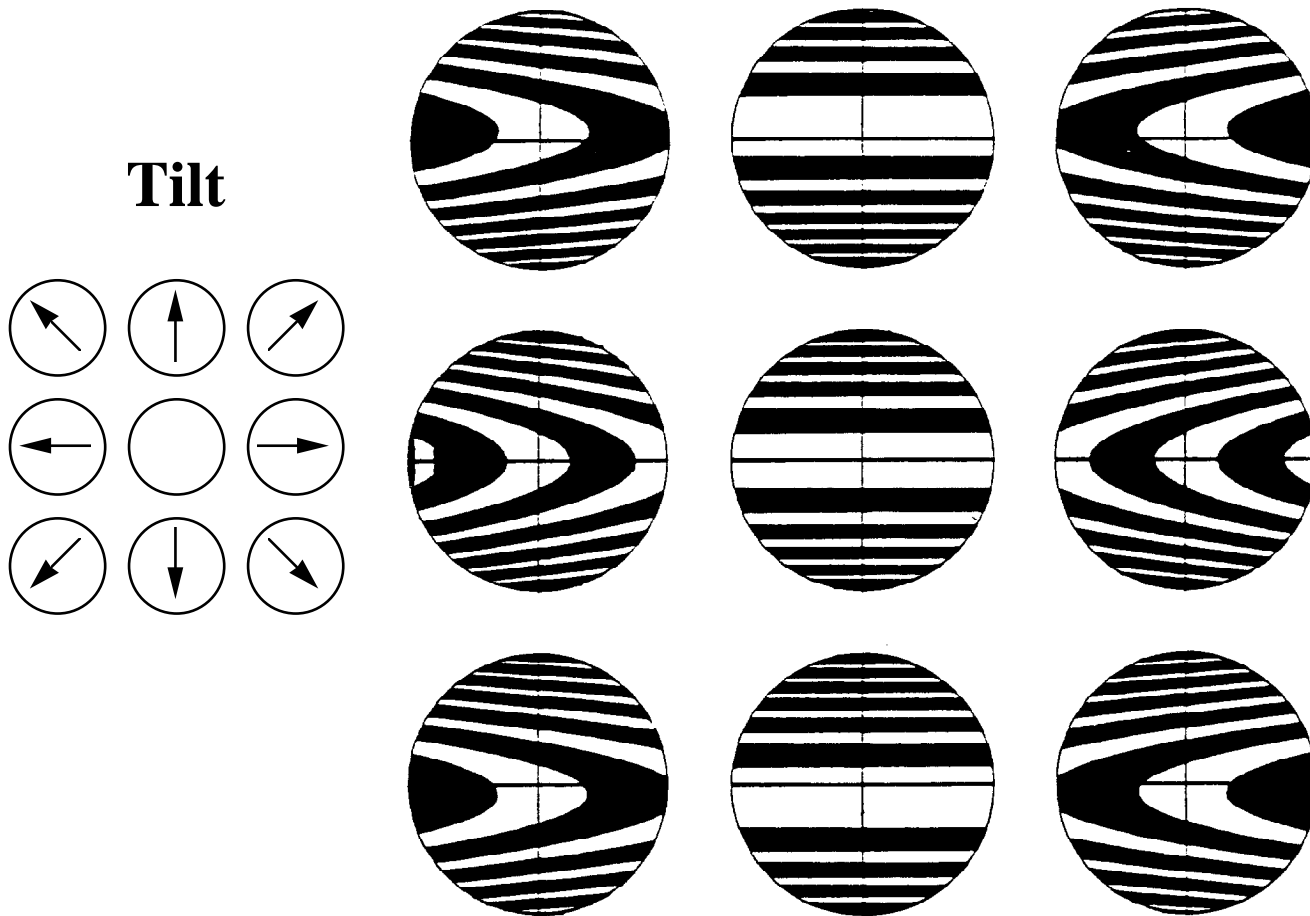

# Interferograms, Large Astigmatism, Medial Focus, Small Tilt

---

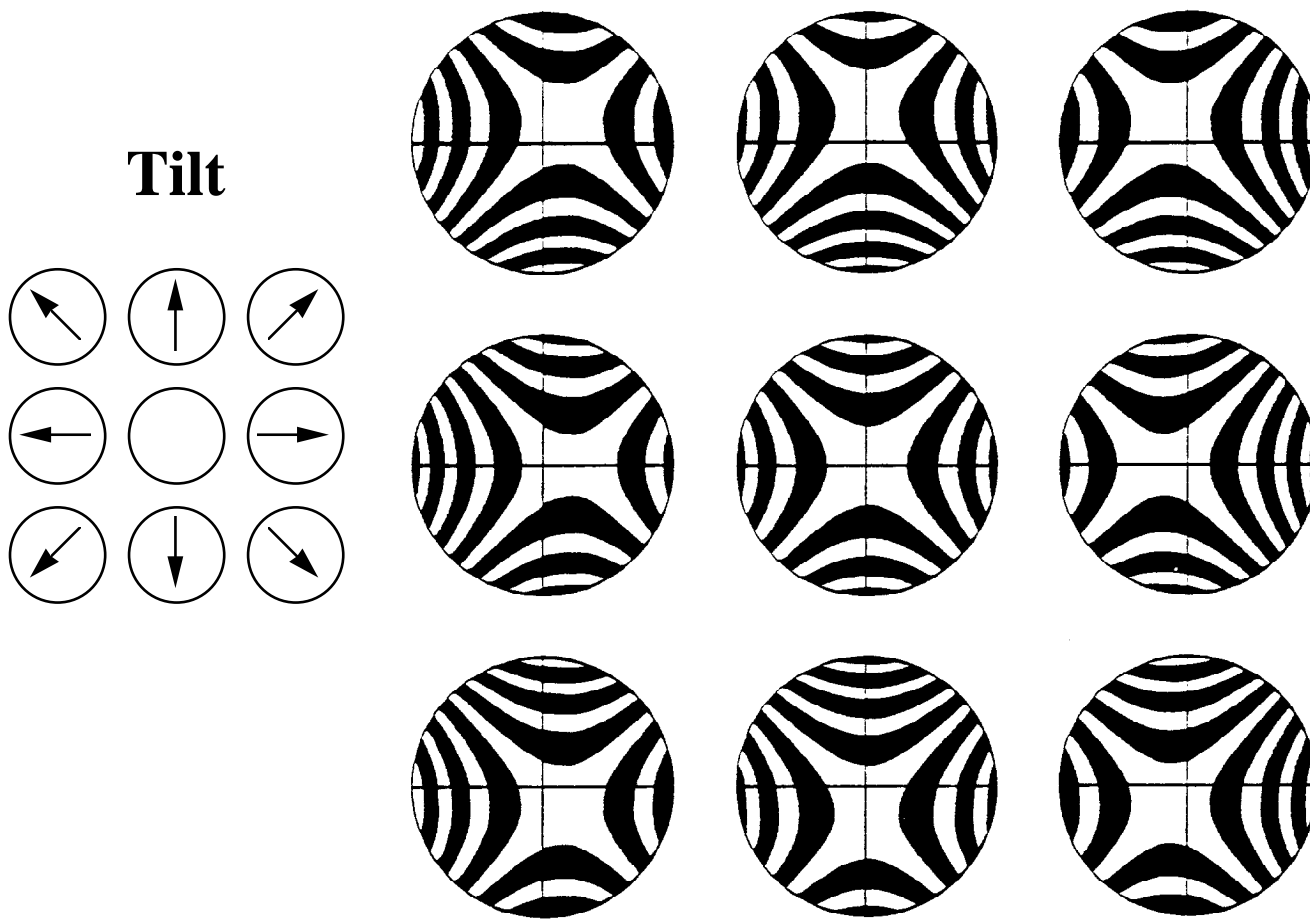

# Interferograms

## Small Coma, Large Tilt

---

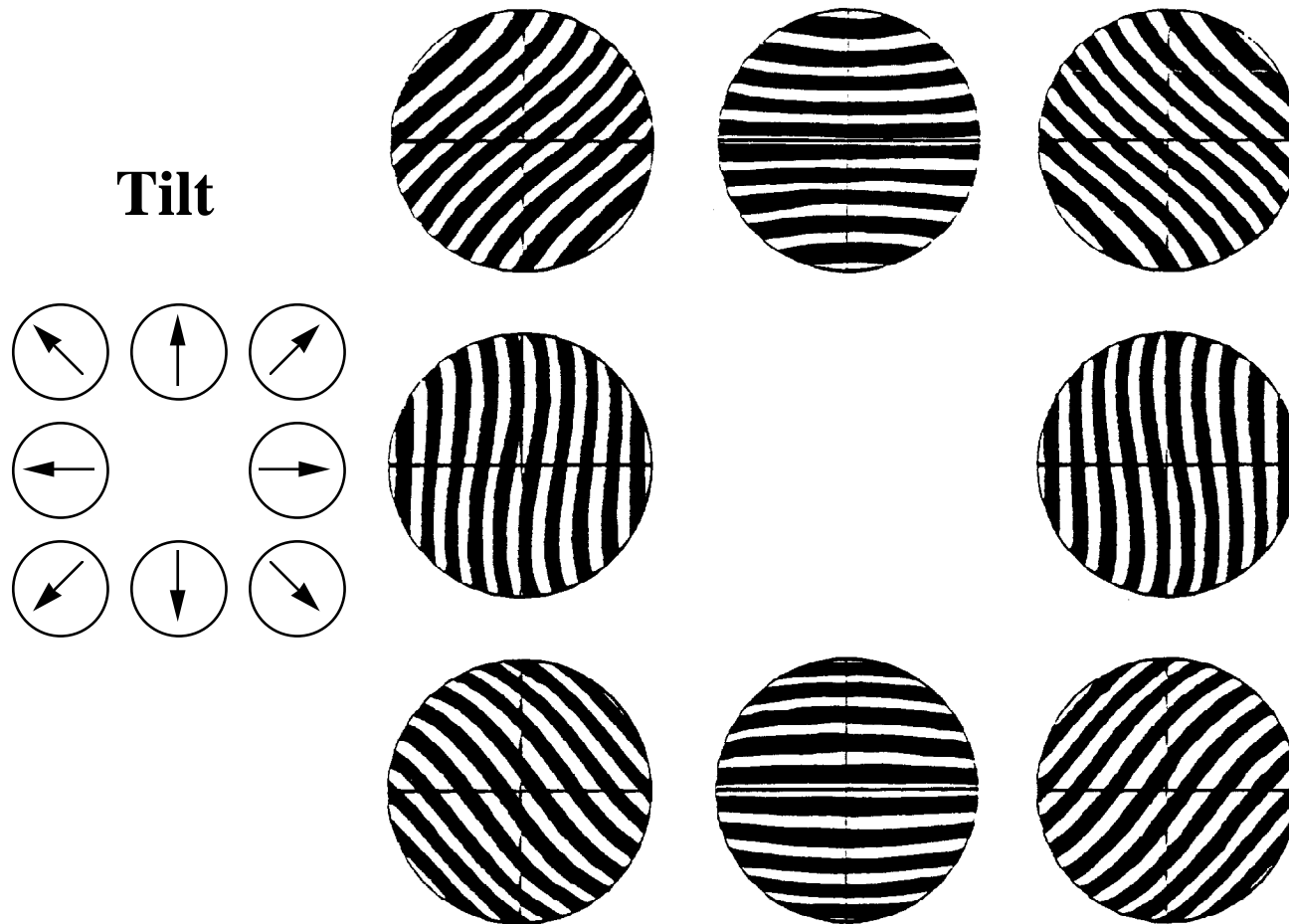

# Interferograms

## Large Coma, Small Tilt

---

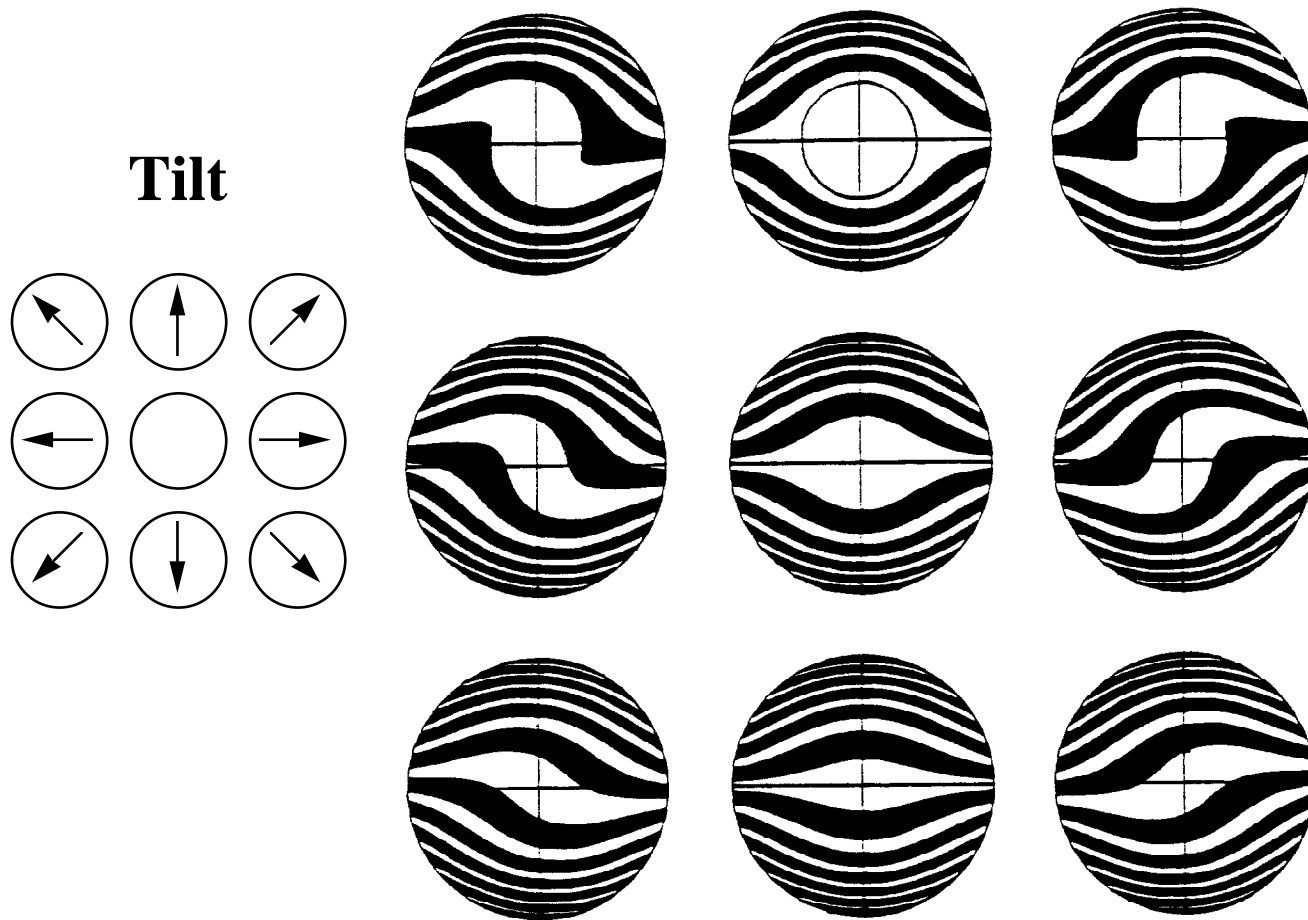

# Interferograms

## Large Coma, Large Tilt

---

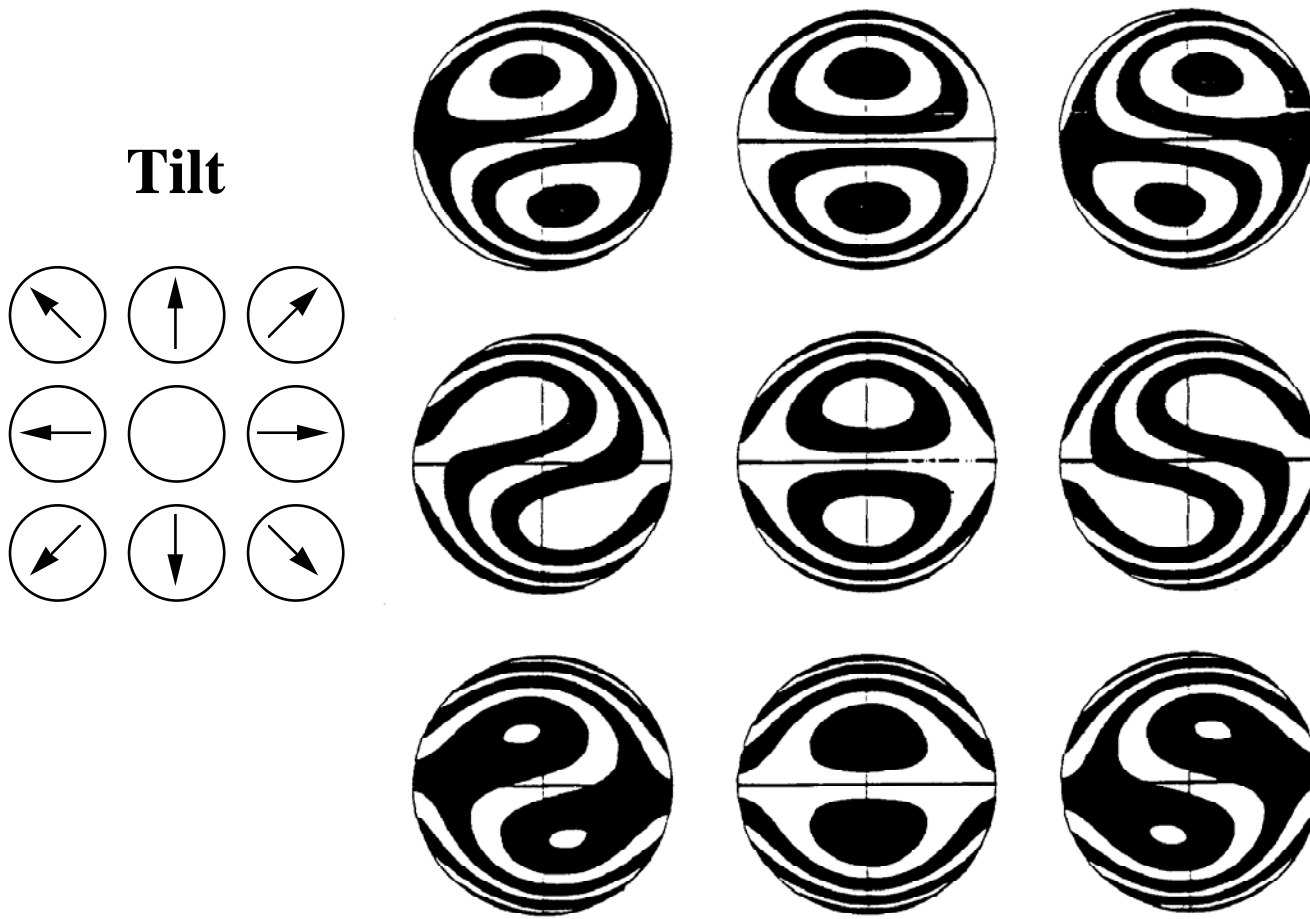

# Interferograms

## Small Focal Shift

---

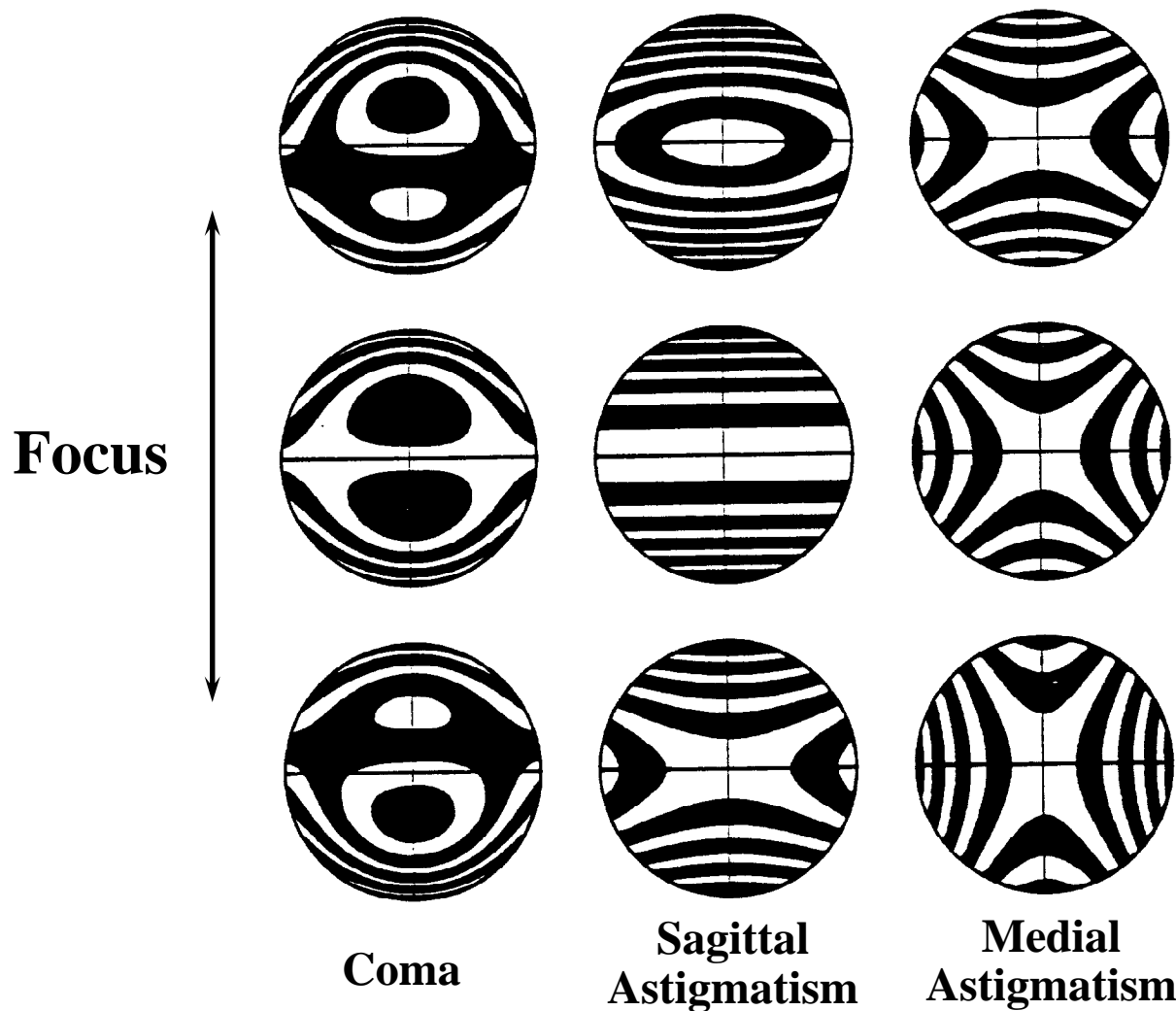

# Interferograms Combined Aberrations

---



Spherical



Sph + Coma



Coma



Sph + Astig



Sph + Coma  
+ Astig



Astig



Coma + Astig

**All wavefronts have  
1  $\lambda$  rms departure  
from best-fitting  
reference sphere.**