

OPTI 420/521 – Introductory Optomechanical Engineering

5. Prisms

a) *Tunnel diagrams and reduced thickness*

b) *Motion of prisms*

beam steering
image rotation

c) *Common prisms and uses*

90° Beam deviation

Right angle prism
Porro (Right angle prism with roof)
Penta prism (and roof penta prism)

Image rotators

Dove (+array)
K mirrors
Abbe (+ folded)
Schmidt (Delta prism)
Pechan

180° beam deviation

plane mirror
Porro
Cube corner

Other

Rhomboid
Porro erecting prisms
Abbe erecting prisms
Anamorphic prisms

References:

Mil-HDBK-141

W. Smith, *Modern Optical Engineering* (McGraw-Hill, 2000).

W. Wolfe, "Non-dispersing prisms" Ch.4 in *Handbook of Optics, Vol II*, 2nd ed. (McGraw Hill, 1996).

Yoder, P. R., *Design and Mounting of Prisms and Mirrors in Optical Instruments*, (SPIE vol. TT32, 1998)

D. Swift, "Image rotation devices – a comparative survey", *Optics and Laser Technology*, Vol. 4, pp 175-188 (1972).

Prof. Shack's prism program

Tunnel diagrams and reduced distance

The optical performance of a prism can be represented by a combination of the methods used for plane mirrors and optical windows.

Unfolding

All of the reflections can be unfolded.

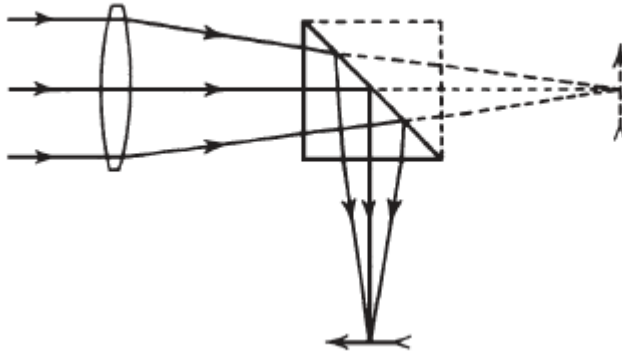

Figure 4.16

(Smith)

Reflections in glass

Use total internal reflection if

$$n \sin \theta > 1$$

(for all angles of incidence)

This is lossless!

However, the surface must be protected. A little smudge ruins it.

For $n = 1.52$, critical angle is 41°

Otherwise, must use reflective coatings

Size of elliptical beamprint

Defined by intersection of light cone with tilted plane

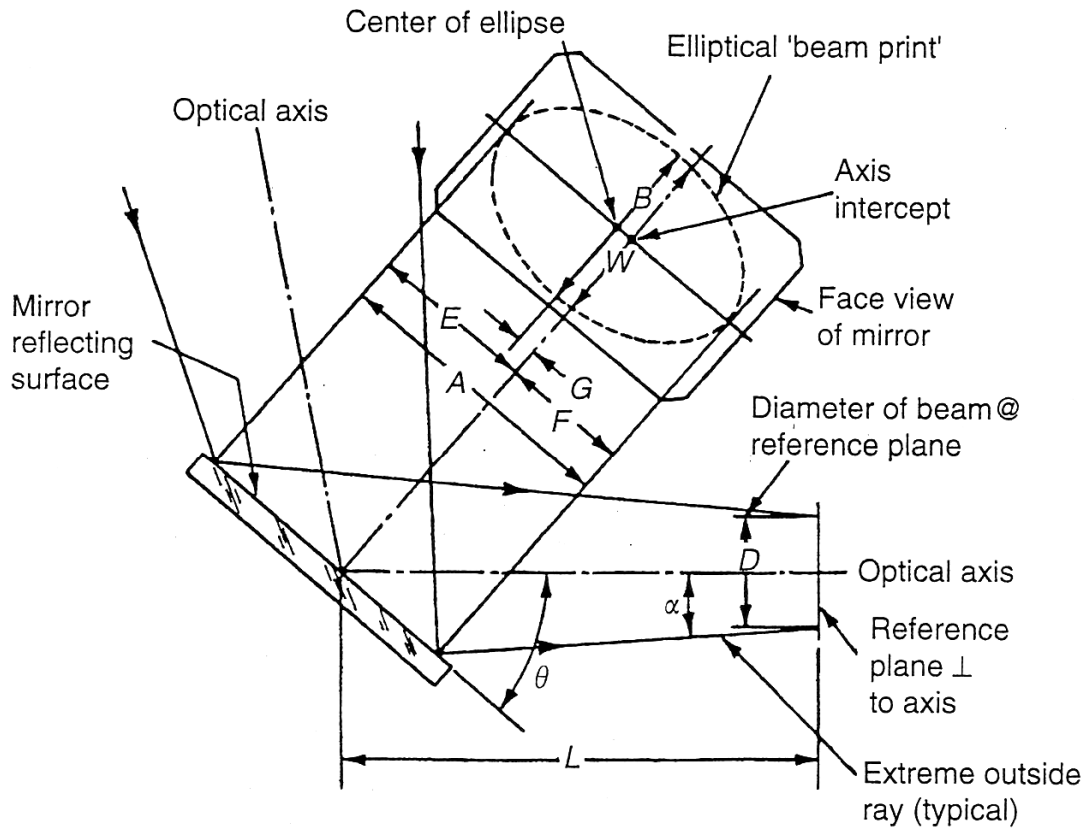

FIGURE 8.8 Geometric relationships used to define the beam print of a rotationally symmetric inclined mirror. (Adapted from Schubert, F., *Mach. Des.*, 51, 128, 1979.)

$$W = D + 2L \tan \alpha$$

$$A = E + F$$

$$E = \frac{W \cos \alpha}{2 \sin(\theta - \alpha)}$$

$$G = (A/2) - F$$

$$F = \frac{W \cos \alpha}{2 \sin(\theta + \alpha)}$$

$$B = \frac{AW}{(A^2 - 4G^2)^{1/2}}$$

Yoder, Paul R., Jr., *Opto-Mechanical Systems Design*, 3rd Ed., (CRC Press, 2006)

Reduced distance

Remember that plane parallel plate causes an image shift

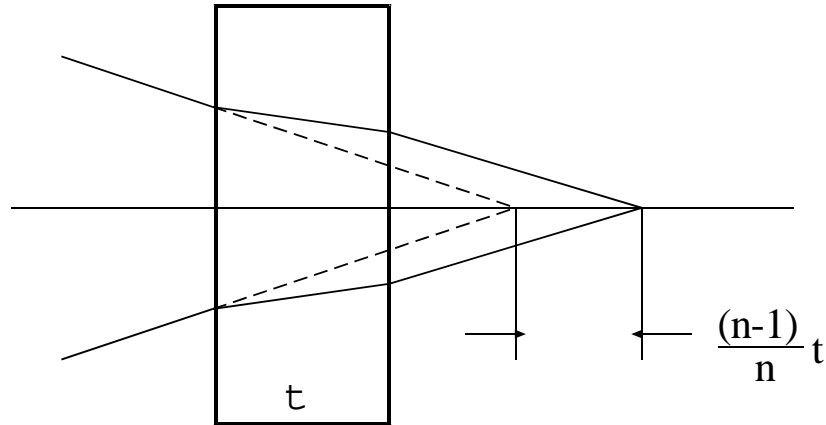

The effect of the image shift from the glass can be accommodated by replacing the glass with the air-space equivalent. If the path length in glass (with refractive index n) is L , then the reduced distance is L/n .

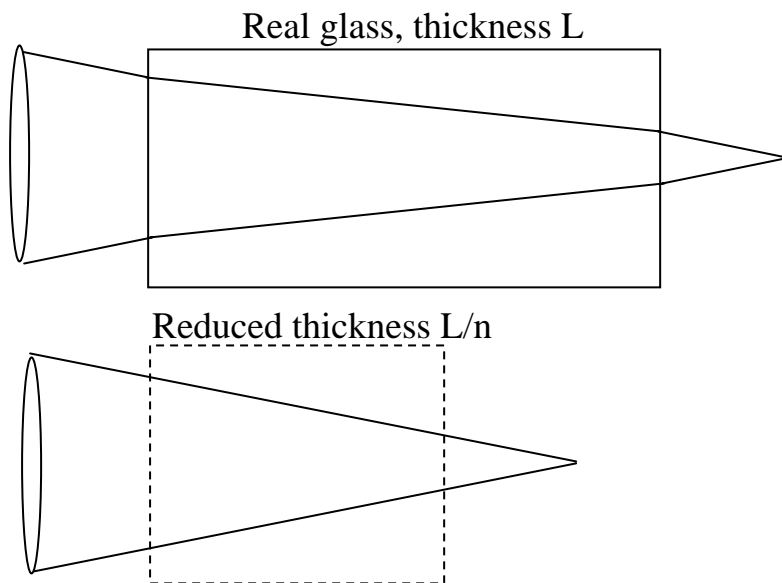

Tunnel diagrams

To represent the first-order properties of the prism, first unfold all reflections, then squash the length to the reduced distance.

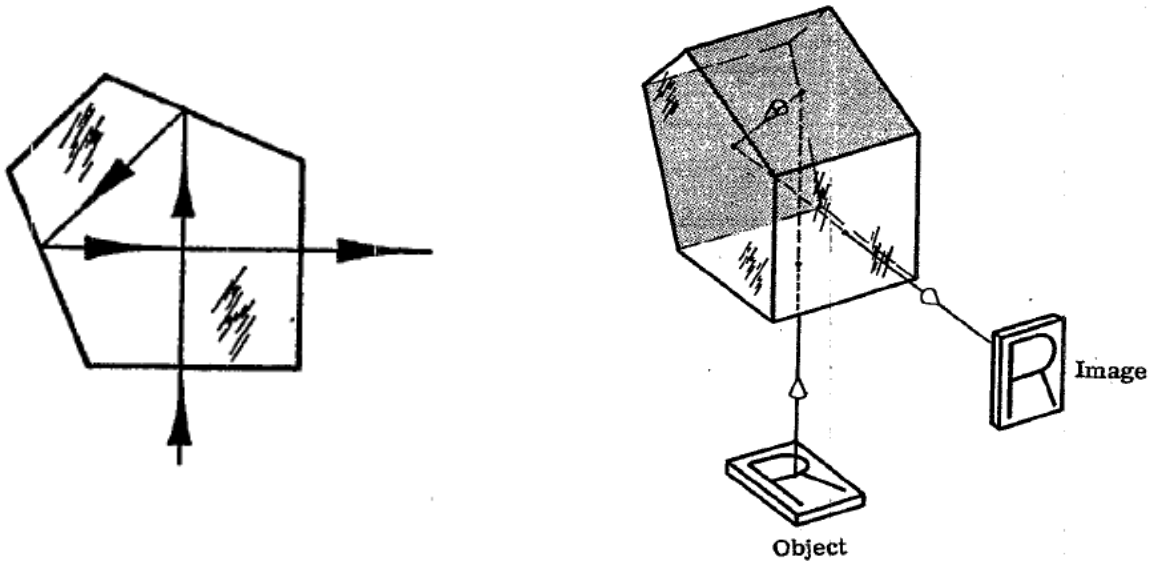

Penta prism gives 90° deviation

Image orientations

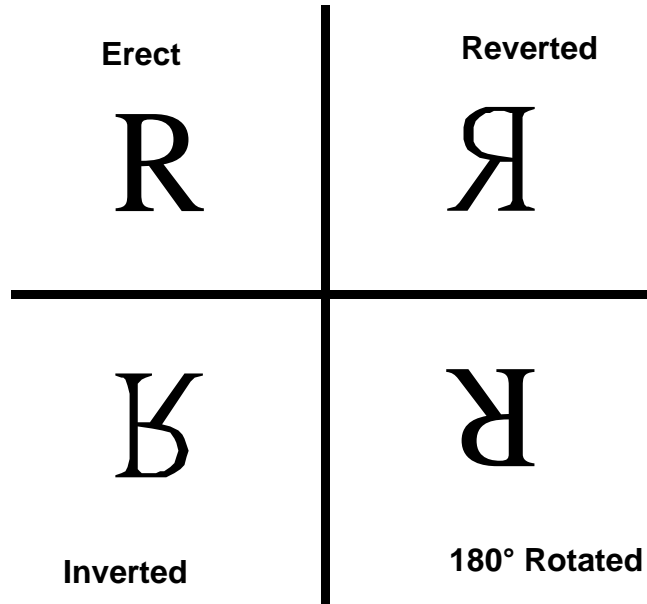

Prism deviation Direct vision

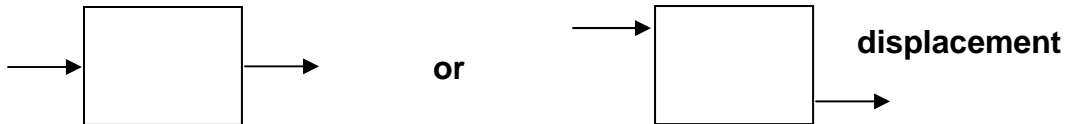

45° deviation



90° deviation

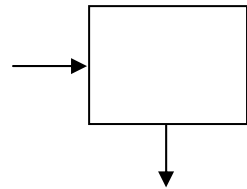

180° deviation

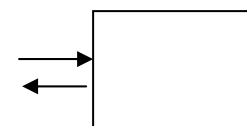

Prism Rotation

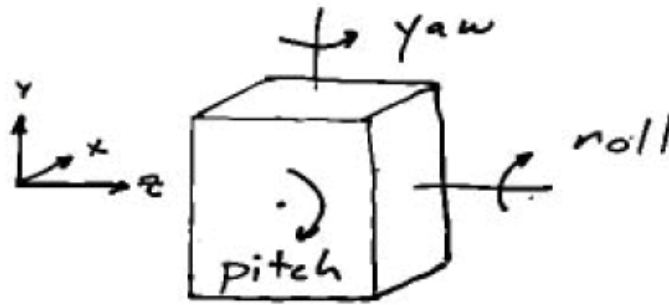

Send coordinate system through
 Line of sight (LOS) $z \rightarrow z'$
 use symmetry to send x or y
 $x \rightarrow x'$

check parity

Even # of reflections

Even parity - Right Handed

odd # of reflections

odd parity Left Handed

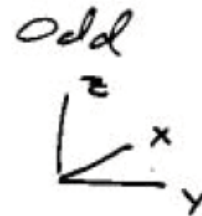
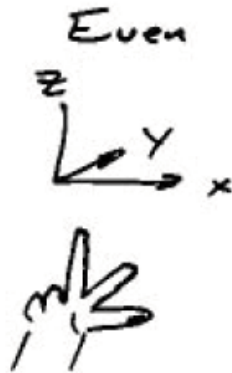

90° deviation prisms

Right angle prism

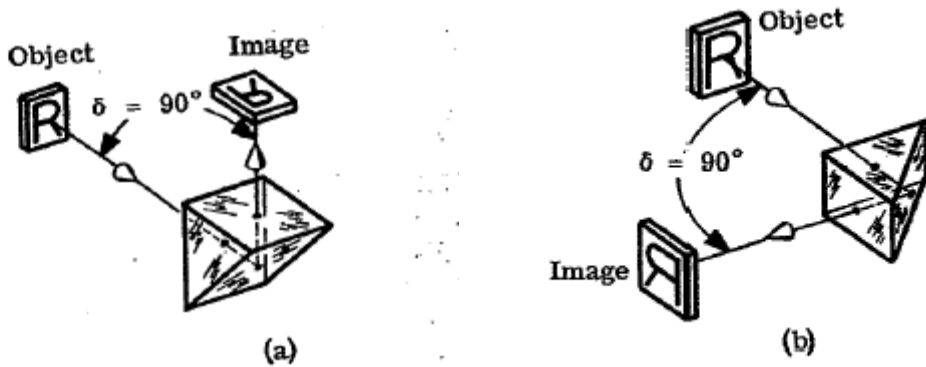

(Mil-Hdbk-141)

Amici prism (sometimes called a roof prism)

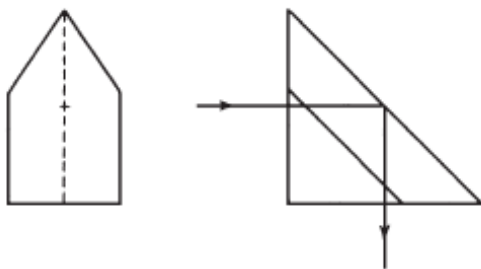

Figure 4.21 prism.

The "V" indicates roof

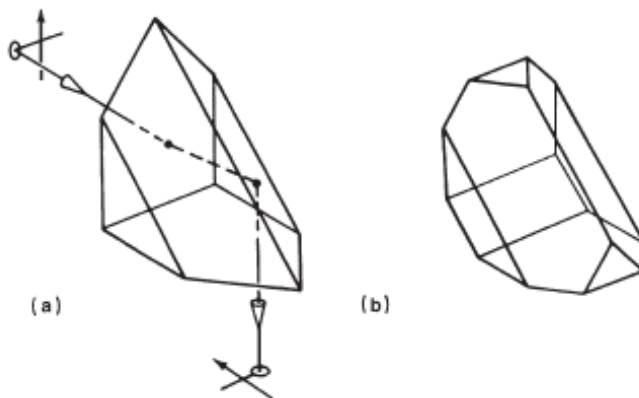
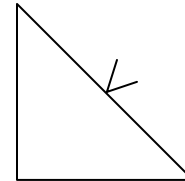
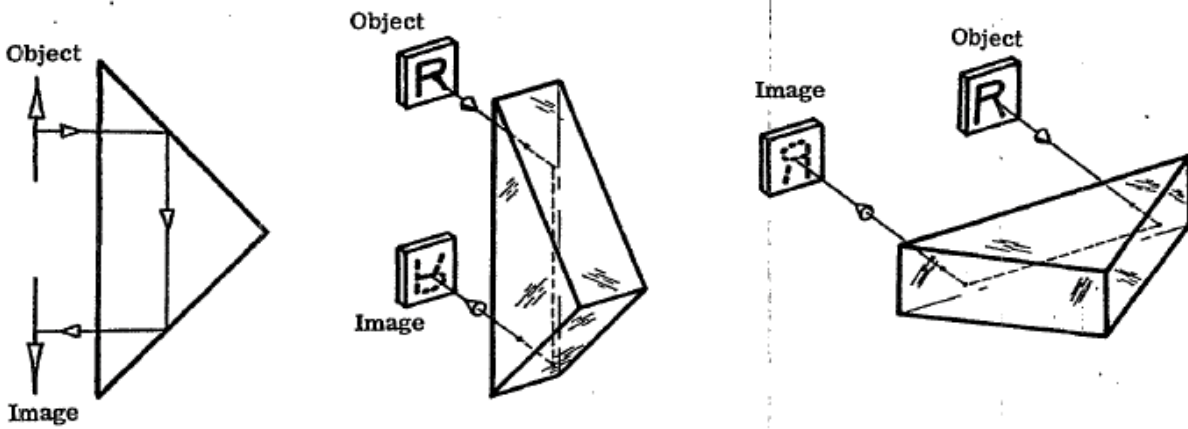

Figure 4.22 Amici prism (a) showing a single ray path through the prism and indicating the image orientation, (b) with truncated corners to reduce weight without sacrifice of useful aperture.

(Smith)

Porro prism



This gives 180° deviation + inversion

Deviation is insensitive to prism pitch

Tunnel diagram

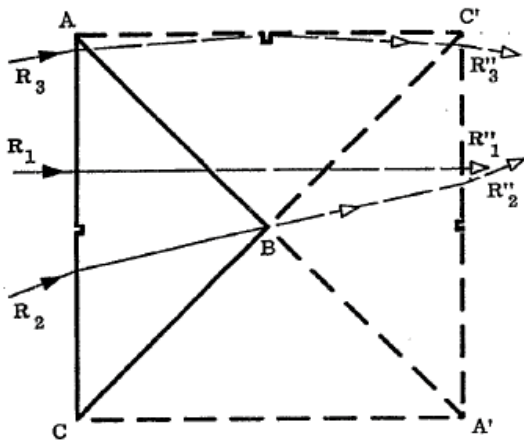

Figure 13.28-Porro prism tunnel diagram.

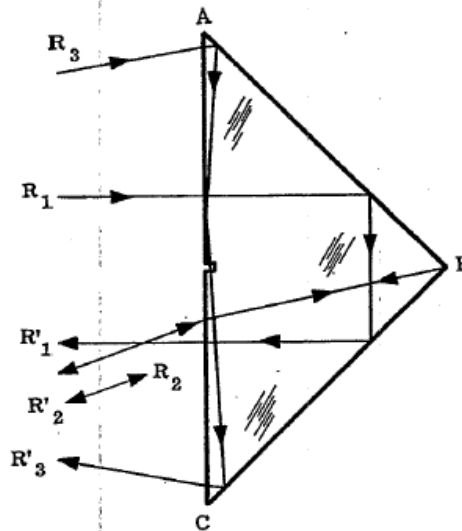

Figure 13.29-The Porro prism.

Applications of Porro prisms

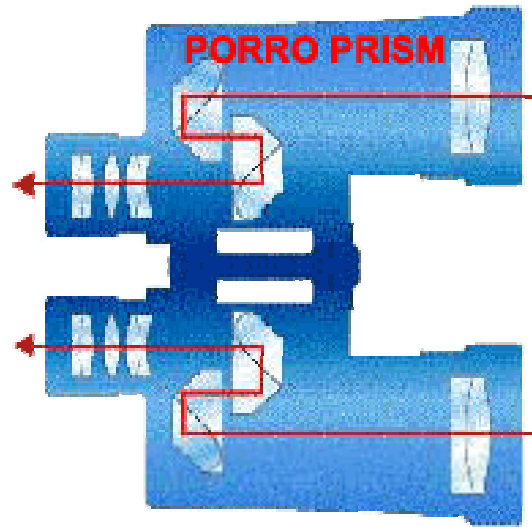
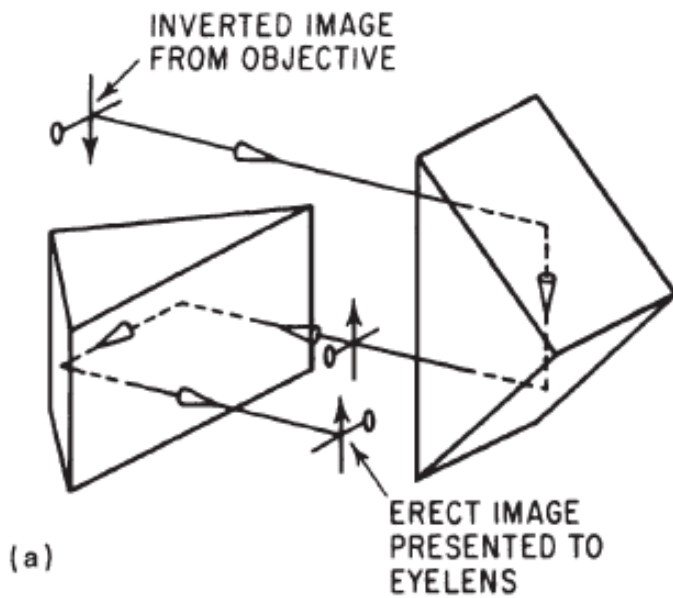

Figure 4.24 Porro prism system (first type) (a) indicating the way the Porro system erects an inverted image. (b) Porro prisms are usually fabricated with rounded ends to save space and weight. Note that the spacing between the prisms has been shown increased for clarity.

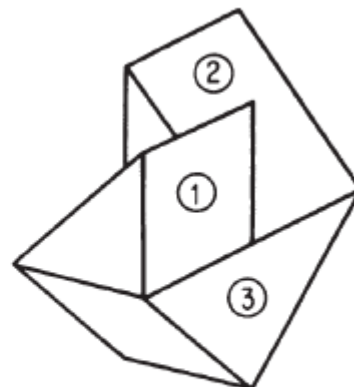
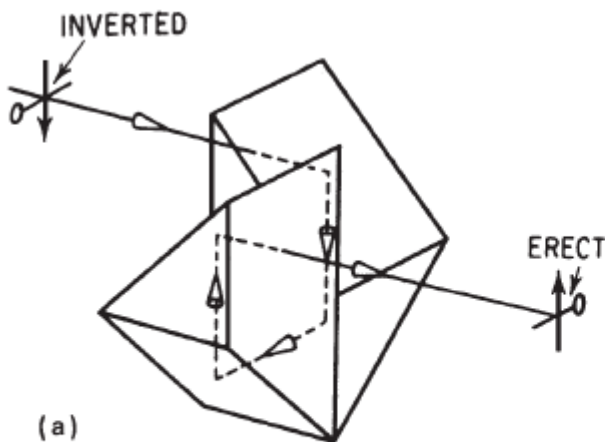
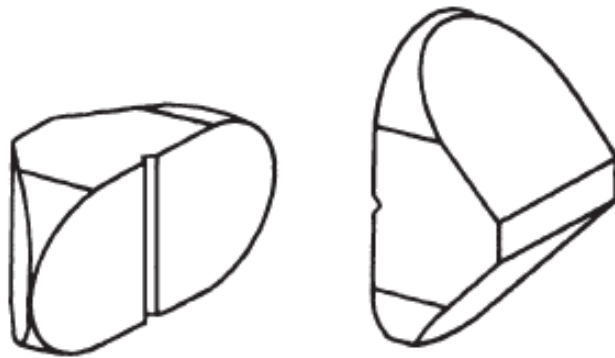

Figure 4.25 Porro prism system (second type) (a) indicating the erection of an inverted image. This system is shown made from two prisms in (a) and from three prisms in (b).

(Smith)

Penta prism

Deviates light by 90° (independent of prism pitch angle)

(This is one of the “magic” prisms)

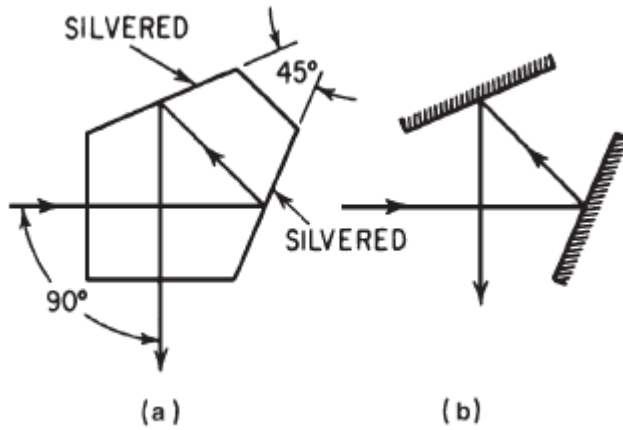

Roof penta prism

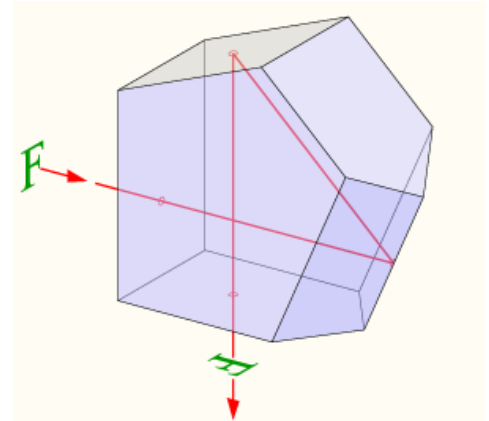

(Smith)

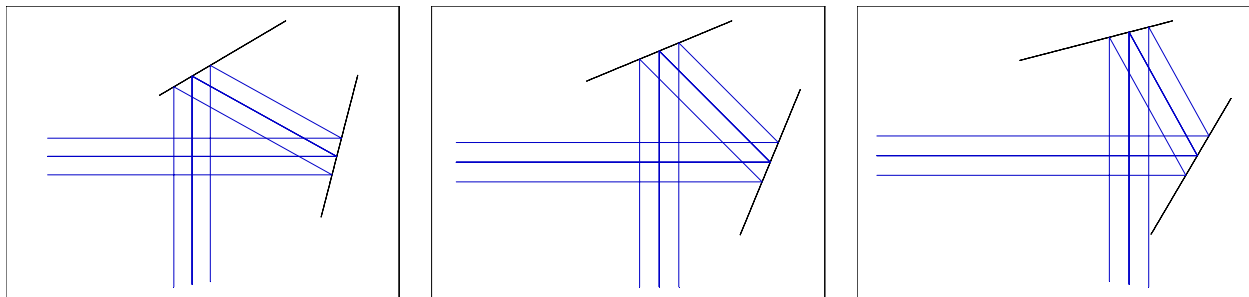

What about roll and yaw?

Direct Vision prisms Rhomboid

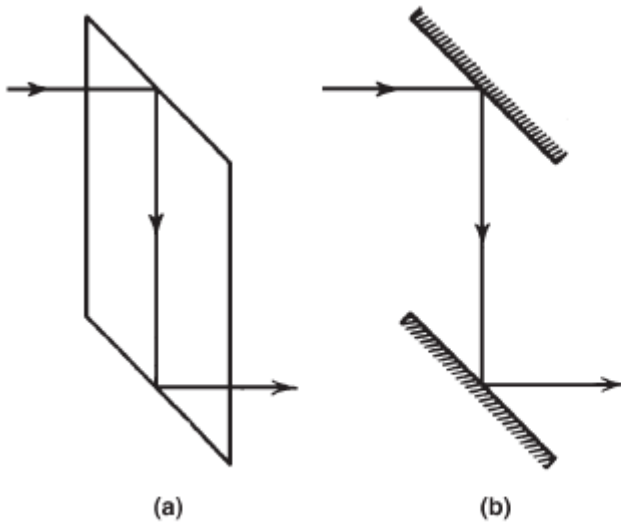
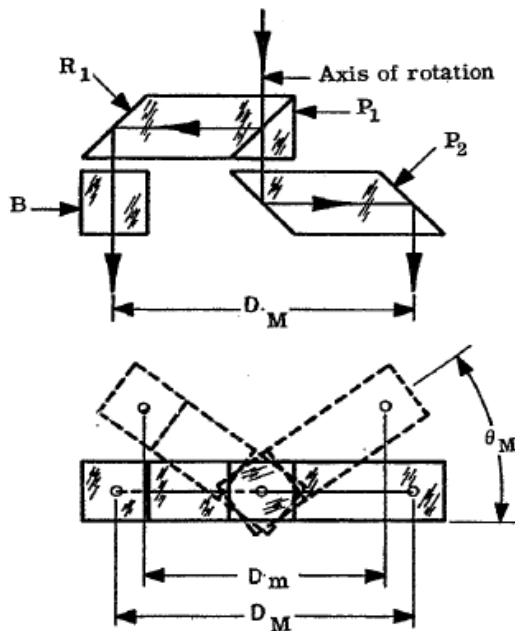

Figure 4.30 (a) Rhomboid prism. (b) An equivalent mirror system. Both systems displace the optical axis without deviation or reorientation of the image.

This is a “magic” prism.

It deviates the light, but does not change the angle *even if the prism is rotated about all axes*

Can be used in a system to create binocular output



(Mil-Hdbk-141)

Microscope Observation Tube Prisms and Beamsplitter

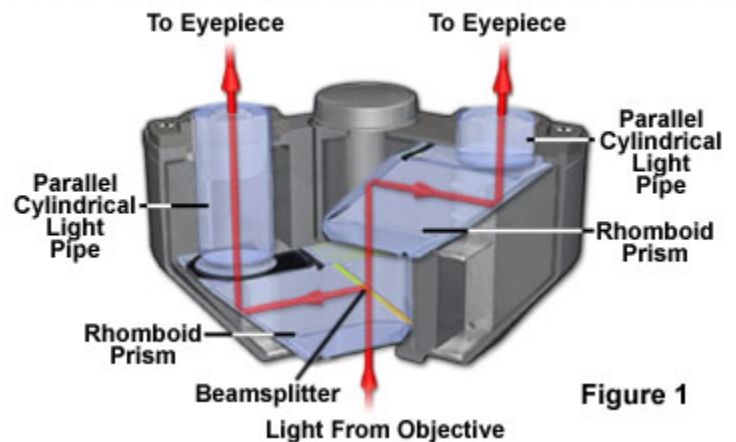
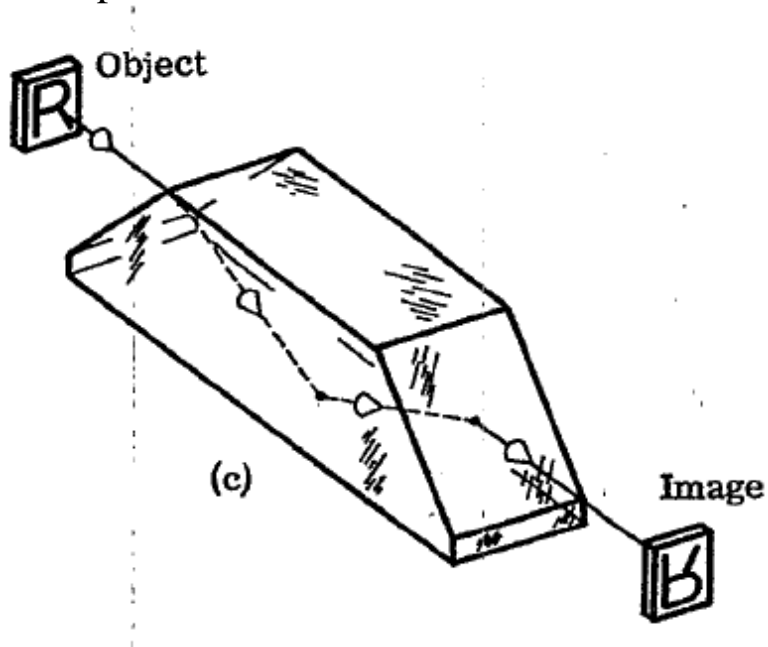

Figure 1

Image rotators

For θ rotation about optical axis, Image rotates 2θ

Dove prism is most common.



(Mil-Hdbk-141)

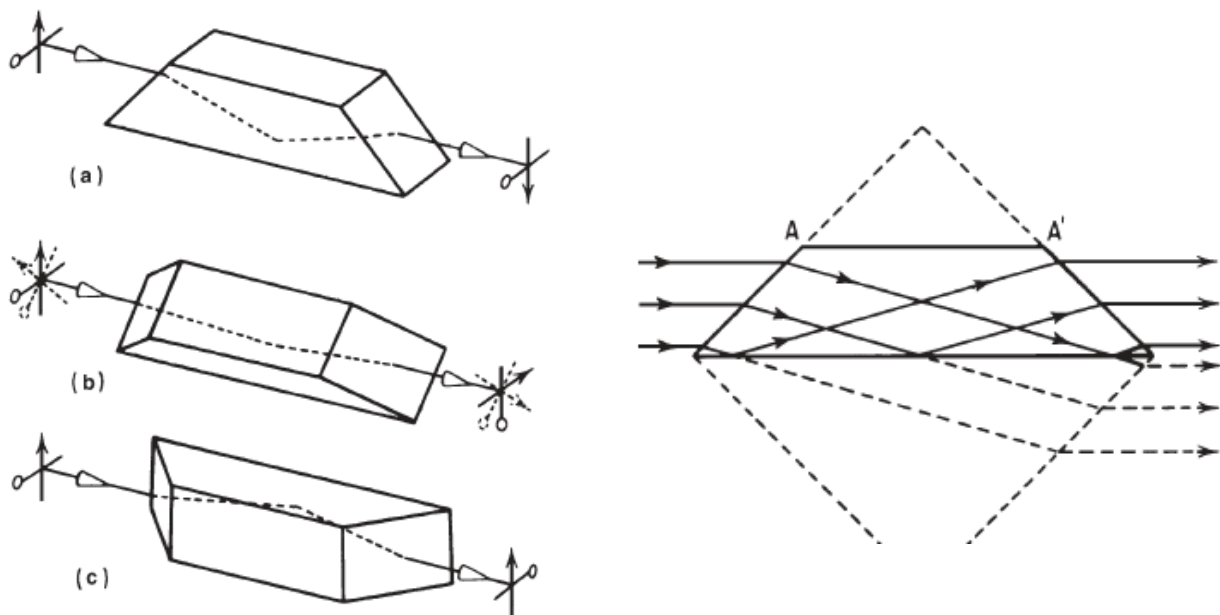

(Smith)

Dove prisms can be used in pairs and arrays

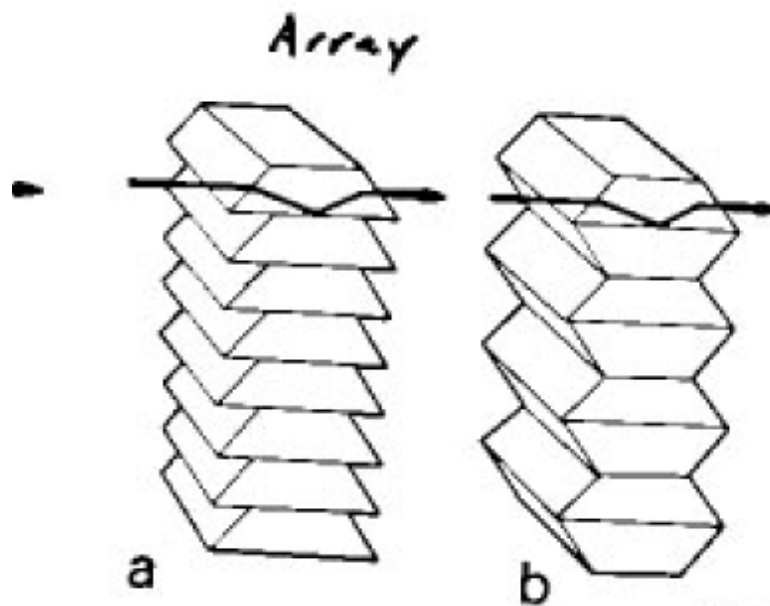
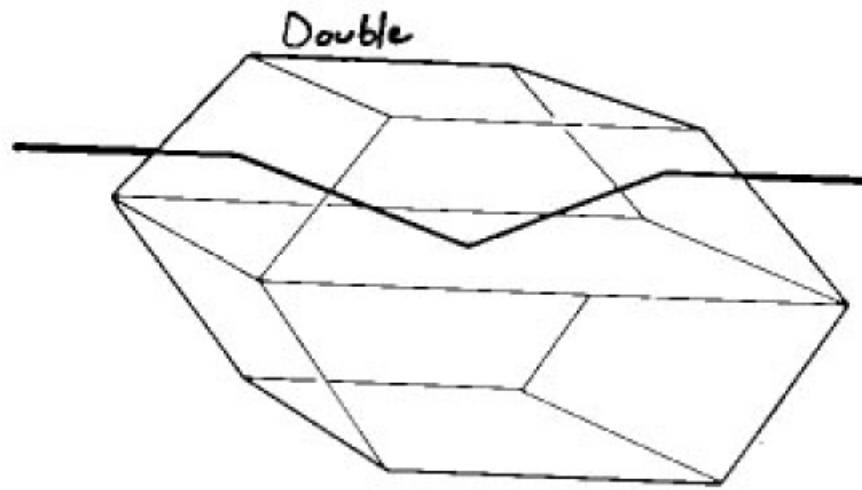

(Swift)

Pechan prism

Compact image rotator

Expensive

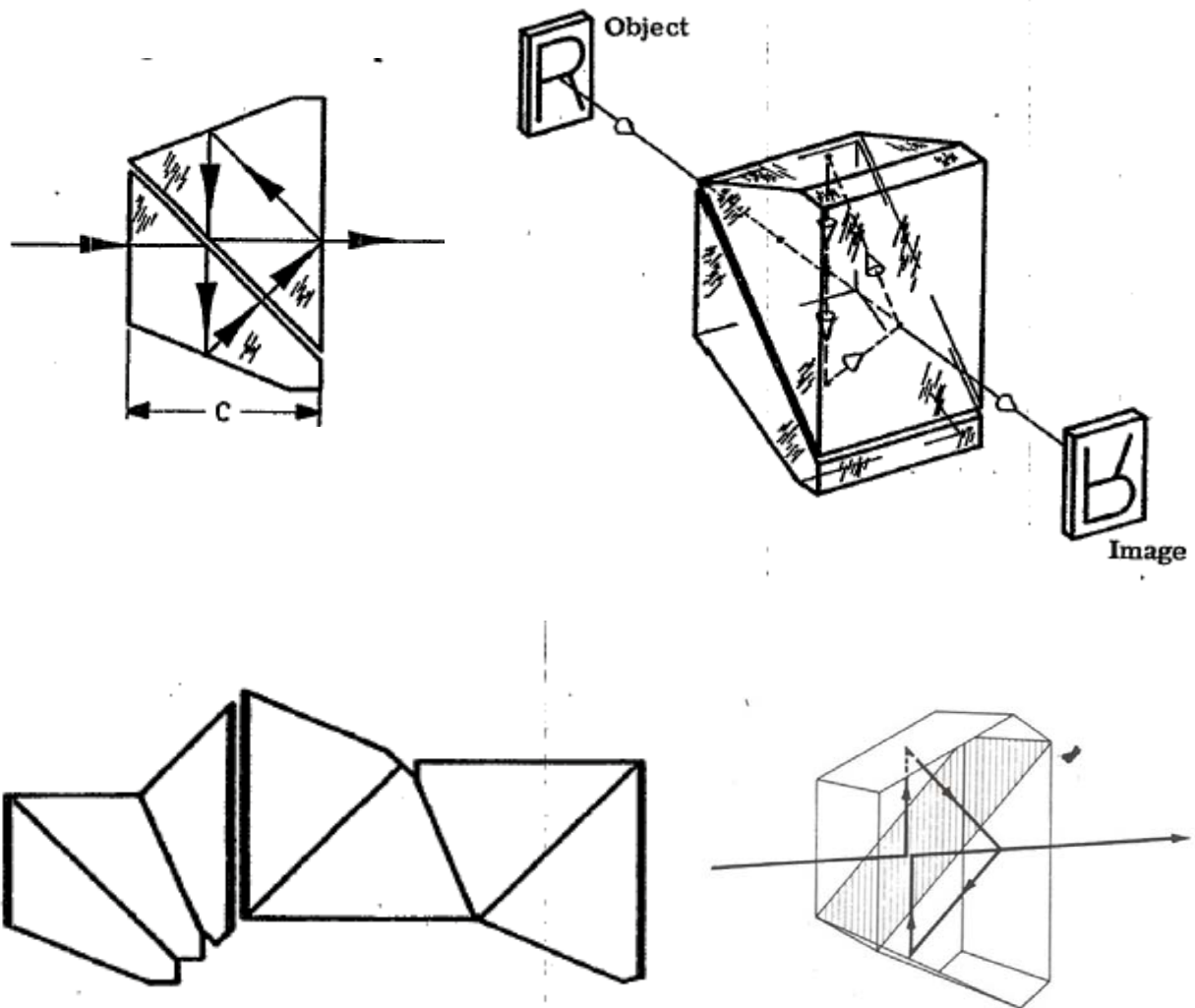
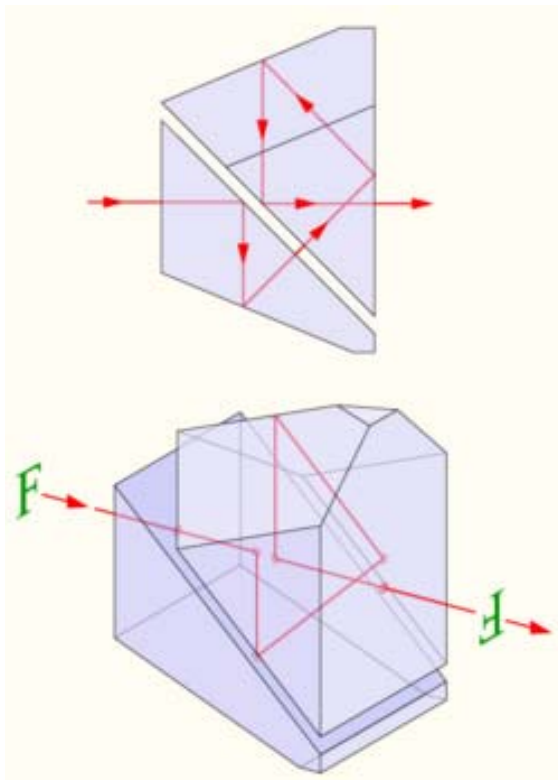
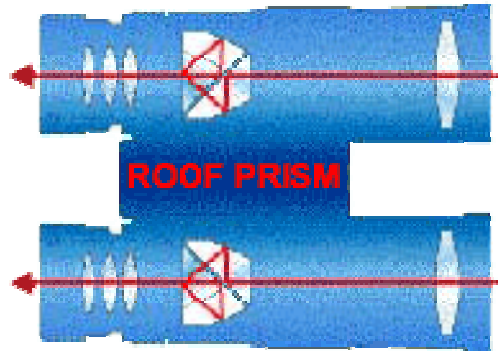
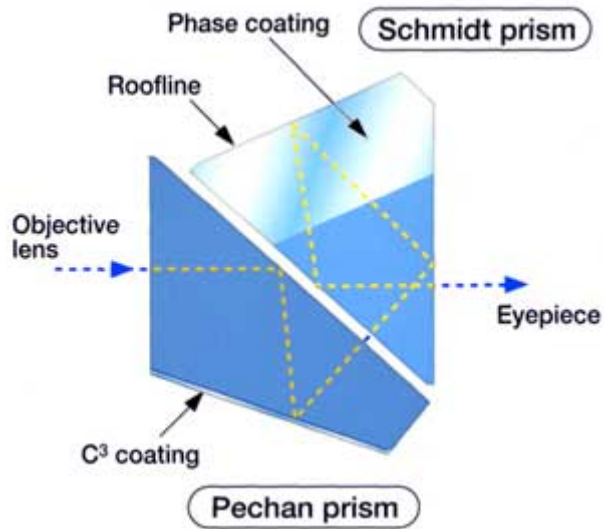

Fig. 22 Pechan rotator

(Mil-Hdbk-141, Swift)

Pechan-Schmidt or “Roof Prism” for image inversion



Abbe Rotation prism

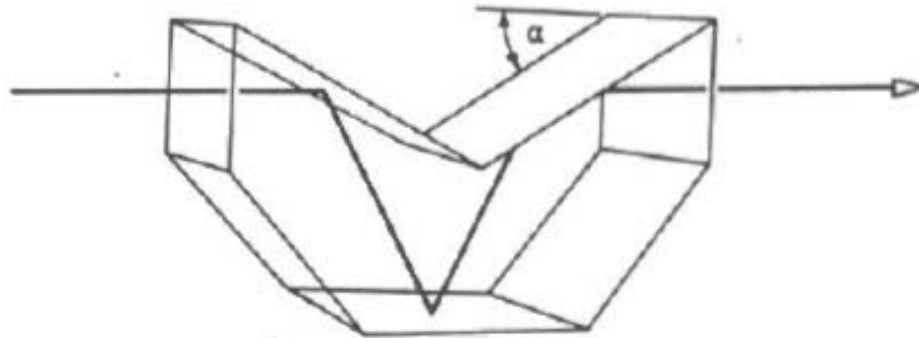

Fig. 12 Abbe type rotator

This can be made from 3 plane mirrors – same geometry

“K-mirrors”

Also, it can be folded:

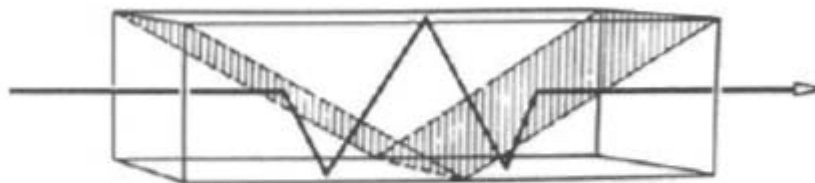
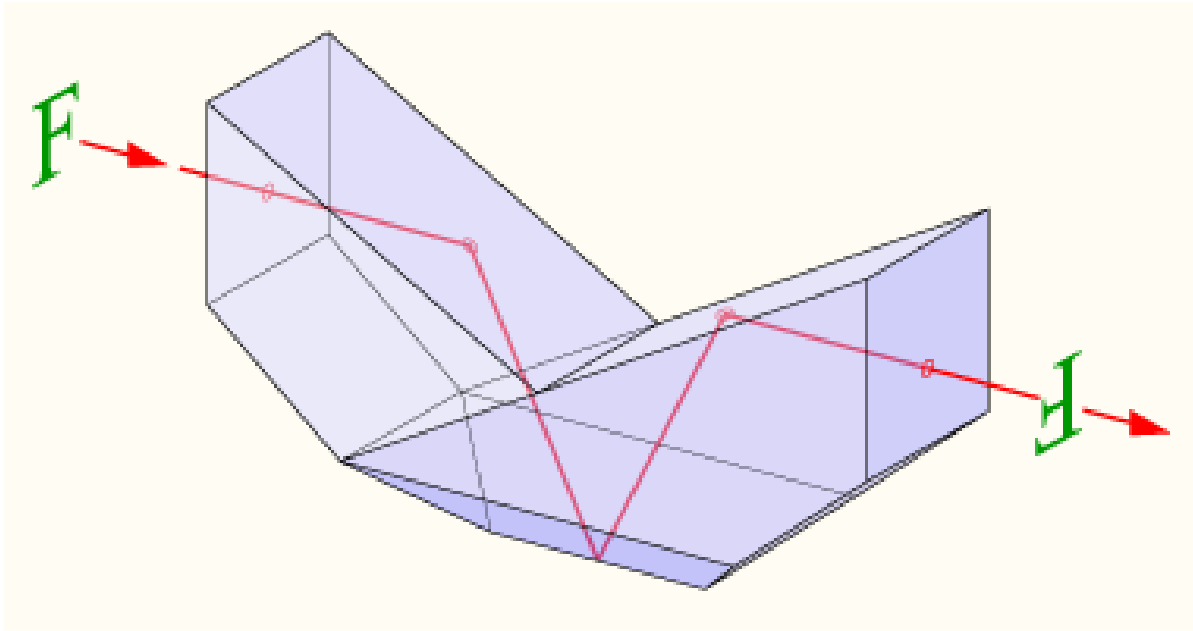

Fig. 15 Folded Abbe type rotator

(Swift)

Add a roof, Abbe-Koenig for inversion



Few surfaces !

Look at coordinate system in and out. Why does the roof convert the prism from an image rotation prism to an image inversion prism



Schmidt rotator prism

Compact image rotator
(Folded Dove prism)
Must be used in collimated light

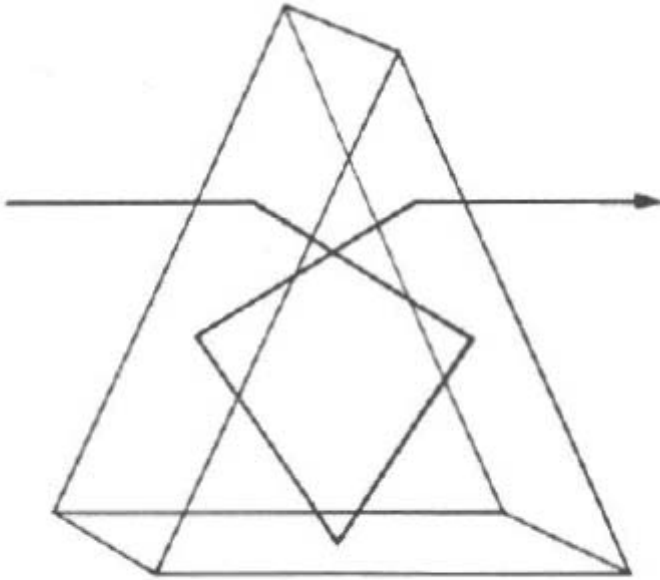

Fig. 7 Schmidt type rotator

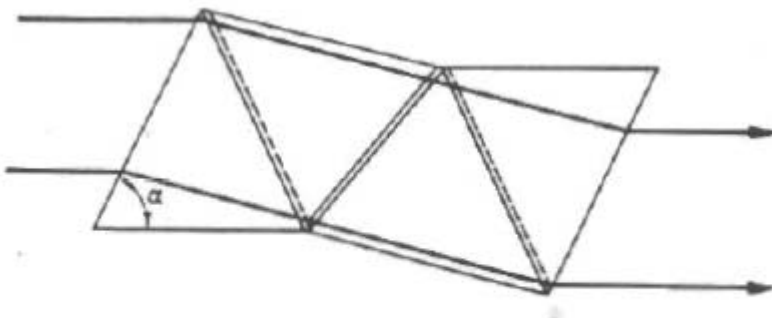

Fig. 8 Schmidt type rotator tunnel diagram
2

Add a roof

(Swift)

Corner Cube

(aka Cube Corner, retroreflector)

3 mirrors, arranged at 90° like a corner

“Magic” prism

Light that hits all 3 mirrors is reflected in the opposite direction as the incident light – independent of orientation of the prism

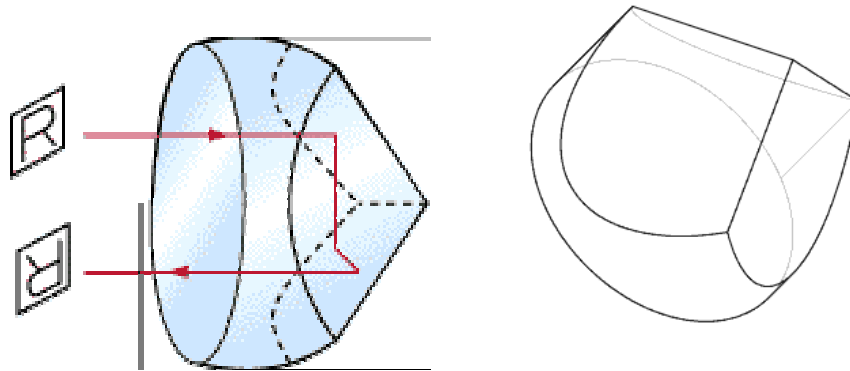

Prism - solid glass uses inside reflections: can be TIR or silver

These are often used in arrays

Hollow- uses first surface mirrors

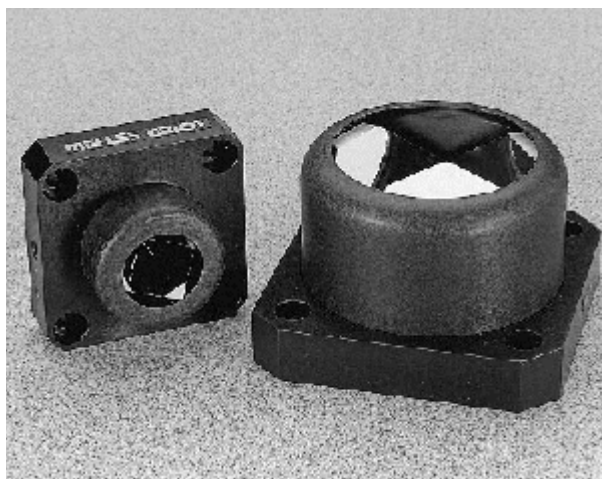

SMR – Spherical mounted retroreflector



Anamorphic prism pairs

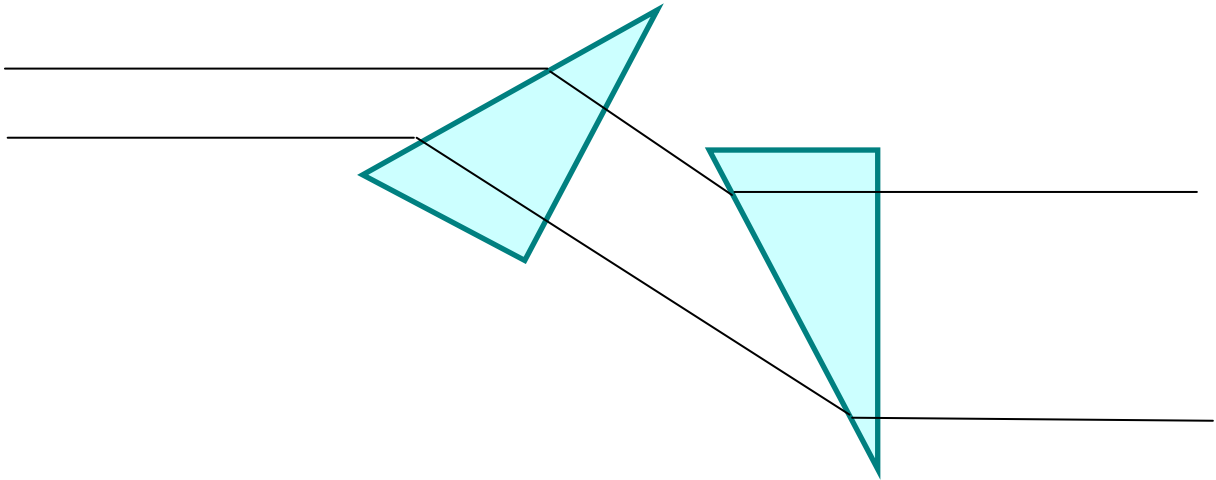

Expands beam in one direction, not in the other

Used to create circular beam from laser diodes

Prisms (from Shack)

