

Guest Lecture

Practical Interferometer Design*

November 2005

James Millerd, Ph.D.
Chief Technology Officer
4D Technology Corporation
Tucson, Arizona

* *Turning ideas into working instruments*

Outline

- **Overview of Interferometers**
- **Design Methodology**
 - Appropriate for systems level design
- **Special Considerations for Interferometers**
- **Design Examples**
- **Summary**

Basic Interferometer

- Measure interference between two coherent optical beams

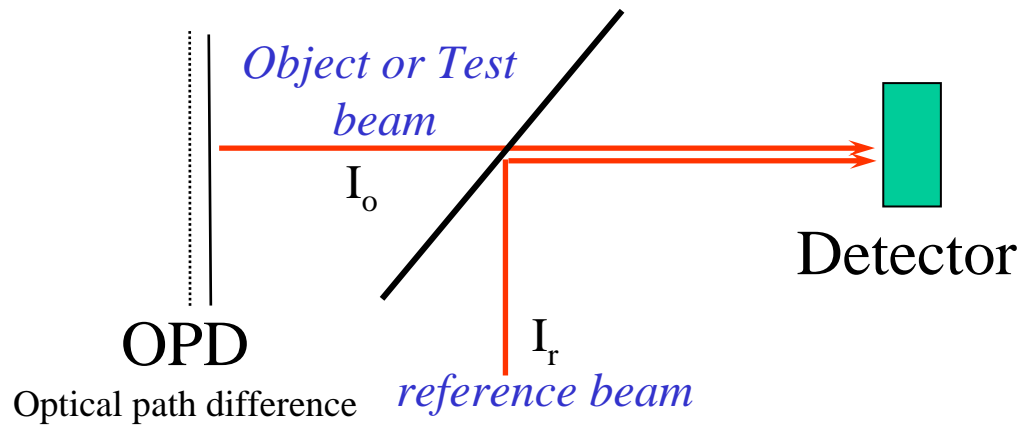

$$I(x,y,t) = I_r + I_o + 2\sqrt{I_r I_o} \cos\left(\frac{2\pi \text{OPD}(x,y,t)}{\lambda}\right)$$

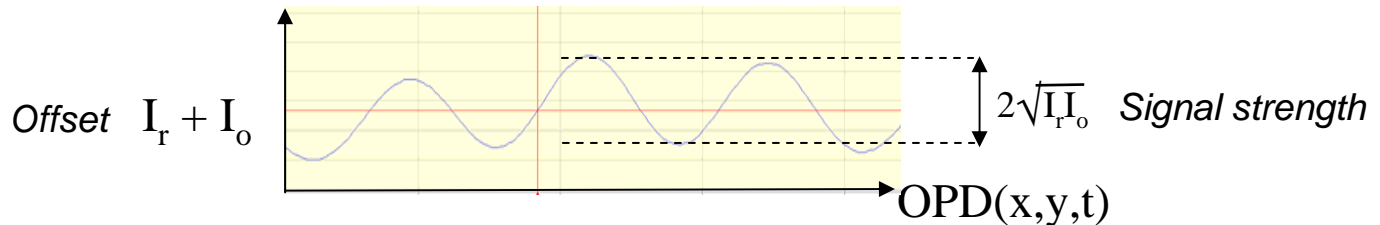

Types of interferometers

– Single point

- Distance measuring
- Vibration measurement
- Wavelength/Frequency measurement

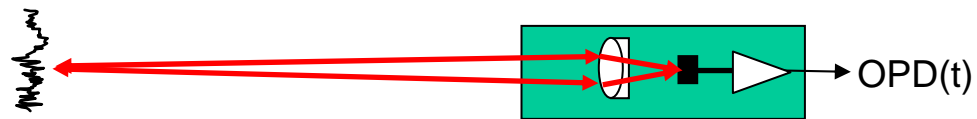

Frequency spectrum

– Full field/Imaging

- Wavefront measurement
- Surface measurement (single λ , multi- λ , white light)
- Displacement measurement (speckle metrology)

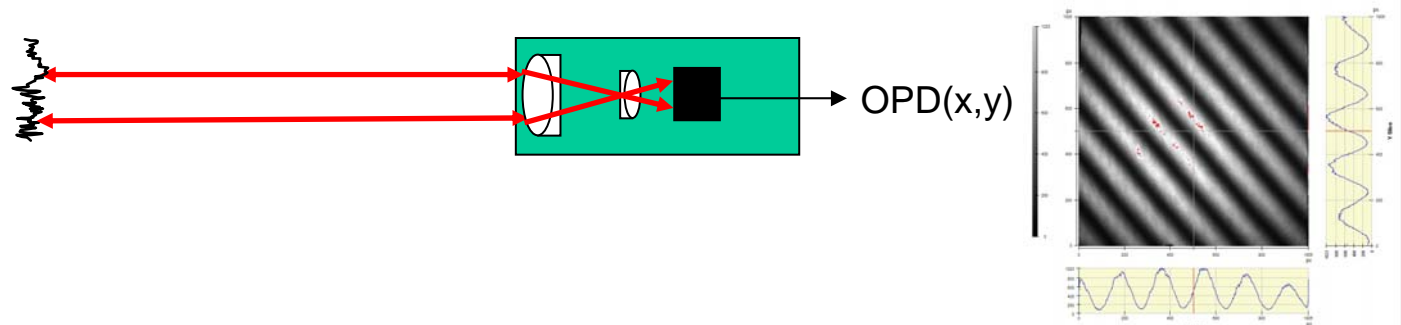

Heterodyne Interferometer

~100 MHz Carrier frequency

Measures small change in OPD to determine surface vibration



VibroMet 500 – sold by MetroLaser

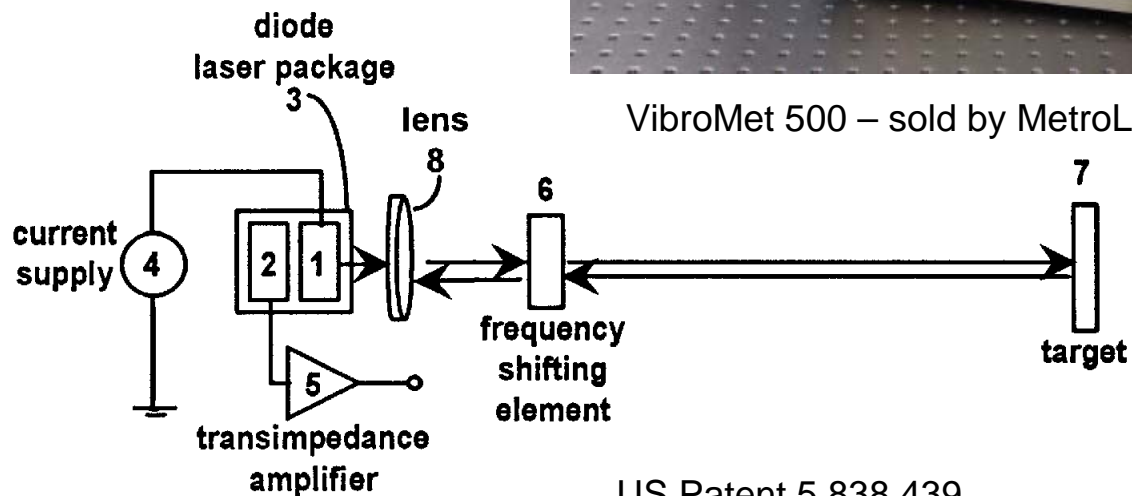

US Patent 5,838,439

Twyman-Green interferometer

Twyman-Green Interferometer

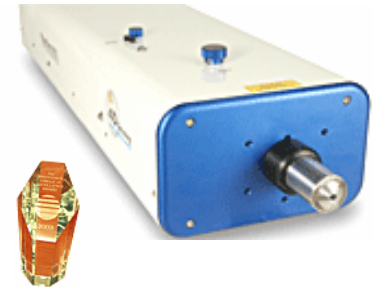
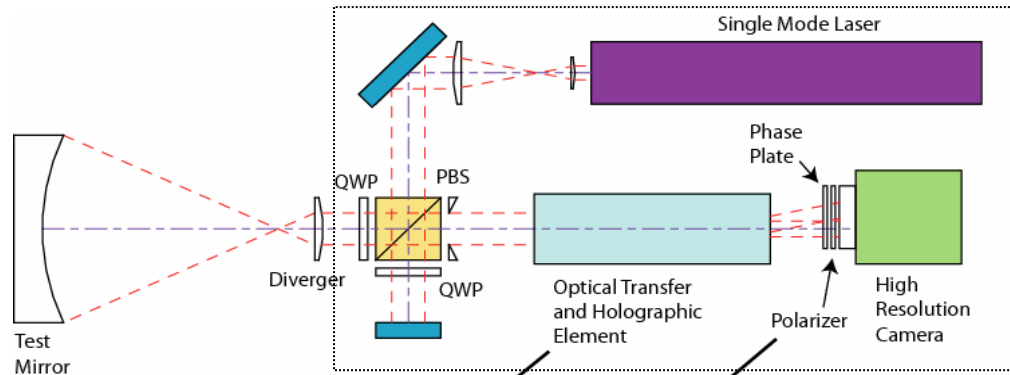

0.3m mirror w/2meter ROC

PhaseCam

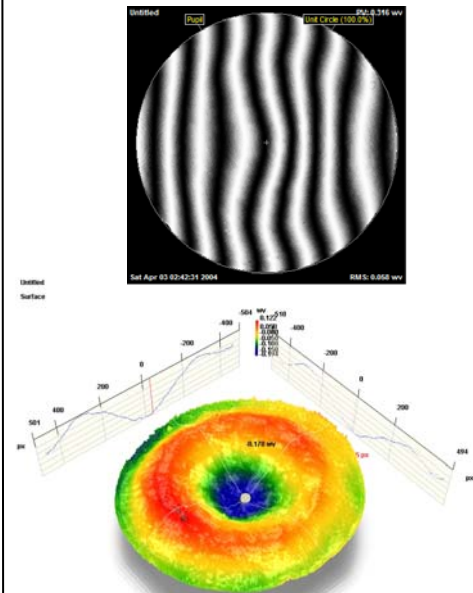
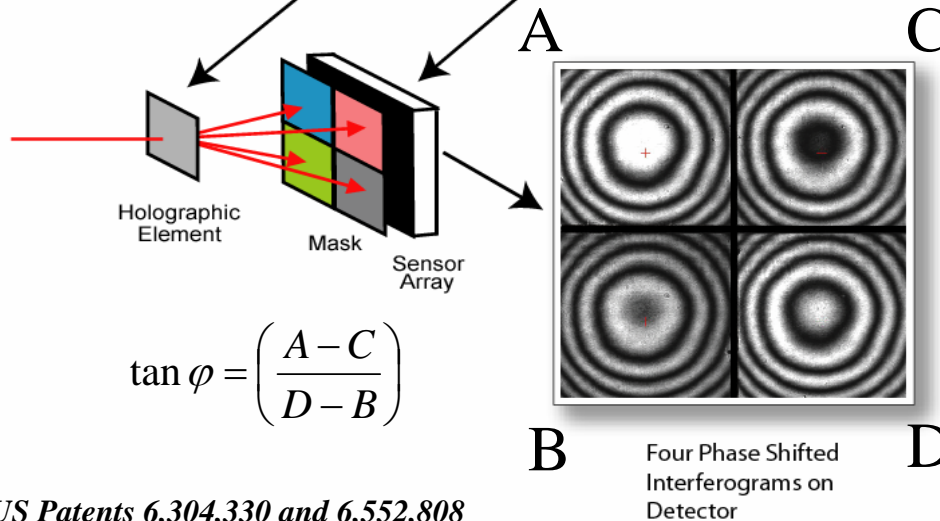

US Patents 6,304,330 and 6,552,808

Speckle interferometer

- High Power
- Fiber pathmatch

Test Article

10 nanosecond pulse

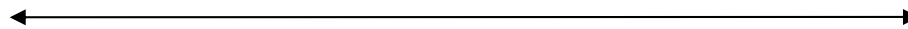

6.4m

Measurement of Mechanical Deformation in 1m Carbon Fiber Target

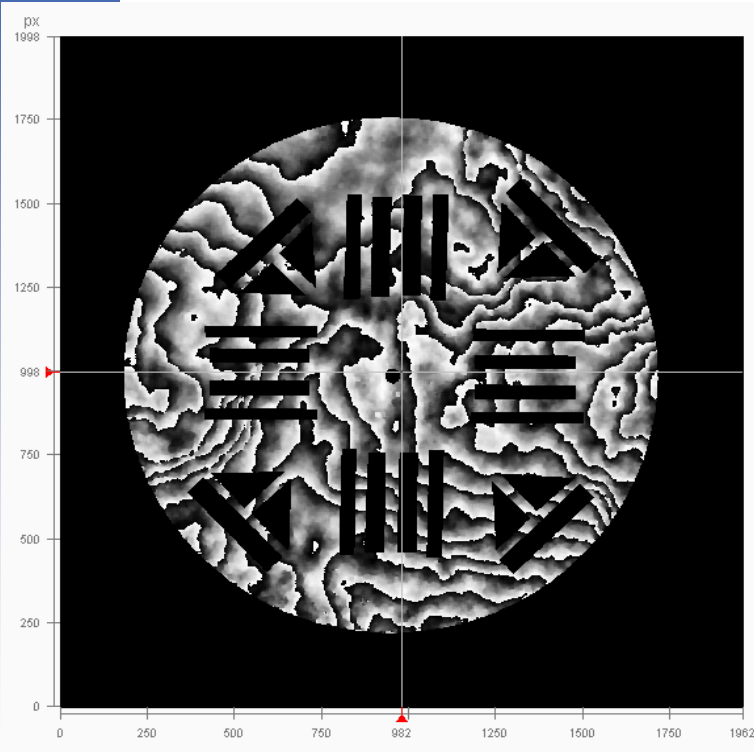

Measurement - baseline

10 nanosecond pulse

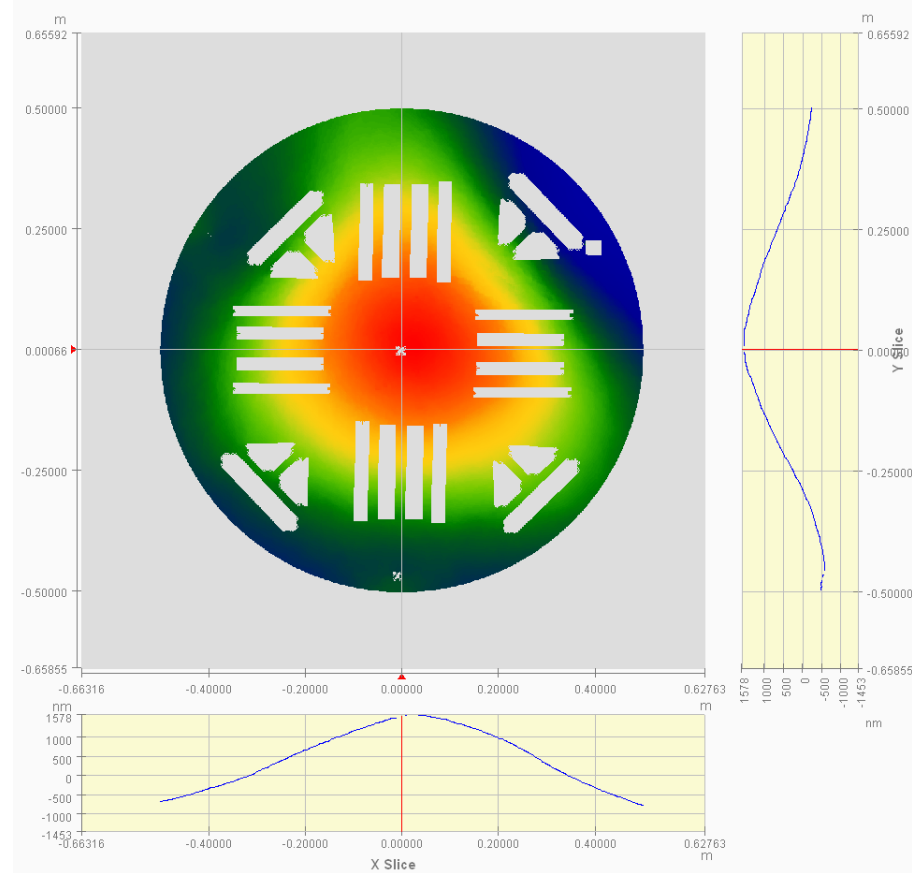

- A Two Step Averaging Scheme Was Used to Mitigate the Effect of Air Turbulence

Fizeau Interferometer

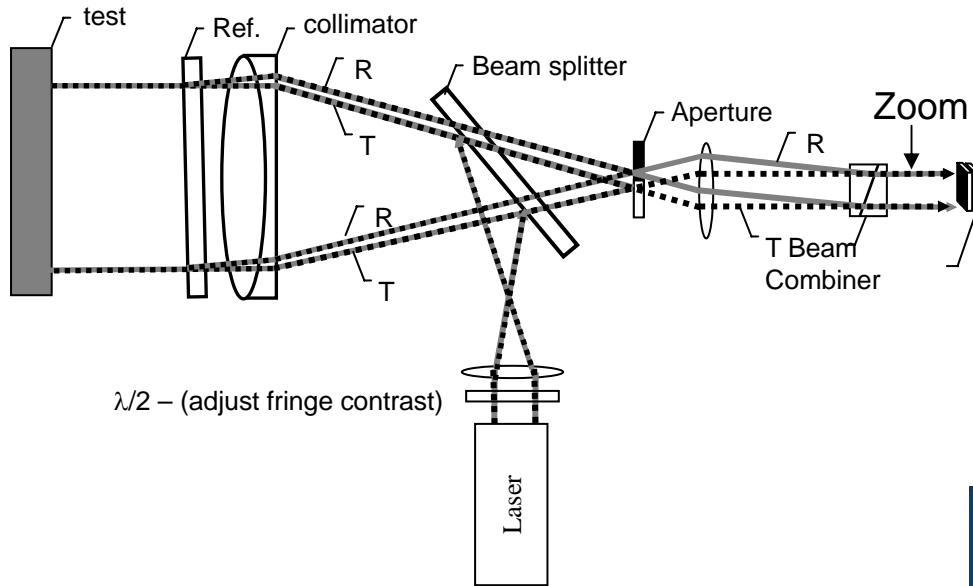

Disk drive excited at 400Hz

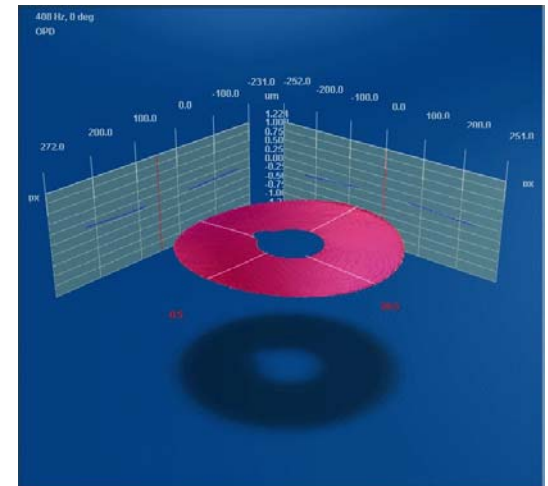

Design Cycle

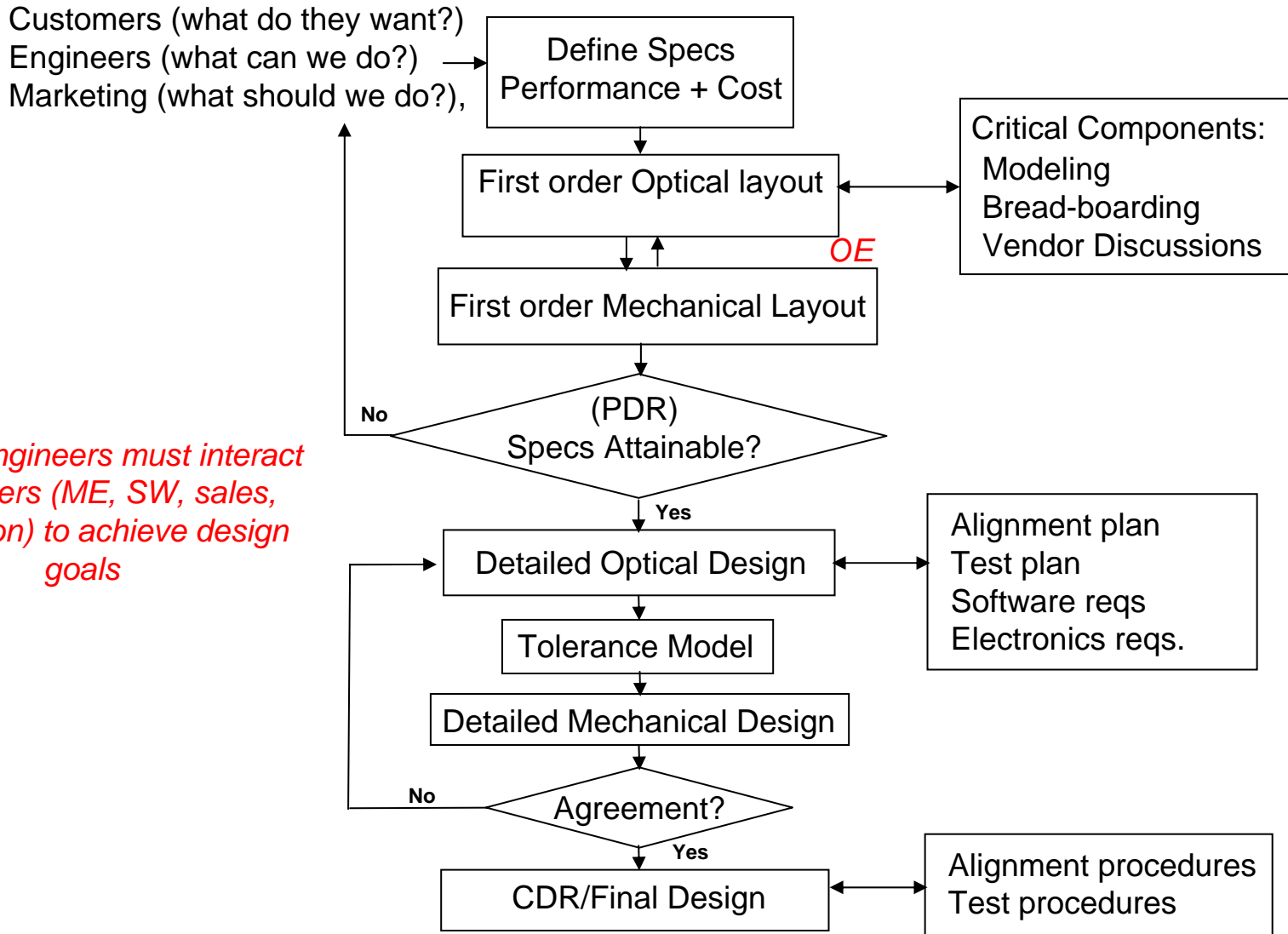

Optical Engineers must interact with others (ME, SW, sales, production) to achieve design goals

Define Specs

What parameters should you nail down before starting the design?

- As many as you possibly can!!
 - Field of view, focus range
 - Wavelength(s)
 - Camera(s) – pixel size, number of pixels
 - Features (zoom, focus, intensity, etc.)
 - Performance (uncalibrated accuracy, retrace, repeatability)
 - Operational environment (temp, vibration)
 - CDRH requirements
 - Reliability requirements
 - Size
 - Cost
 - Schedule

The project has to make sense!



First Order Design

- Simple sketches (by hand, Autocad, visio)
 - Consider how the physical dimensions of the optical design will impact the overall instrument size.
 - Specify and choose components
- Spreadsheets (e.g. Excel)
 - Excellent method to study design tradeoffs
 - Look for problems with first order design before detailed modeling
- First order stray analysis before the detailed design
 - Beam-splitters, windows, prisms
- Detailed verification of components or sub-systems may be necessary to determine viability even at an early stage
 - Modeling (Zemax, Matlab, etc)
 - Breadboard experiments
 - Talk to vendors (what will it cost to make this?)

First order design worksheet(2)

Worksheet for a zoom design – examines f/num and size

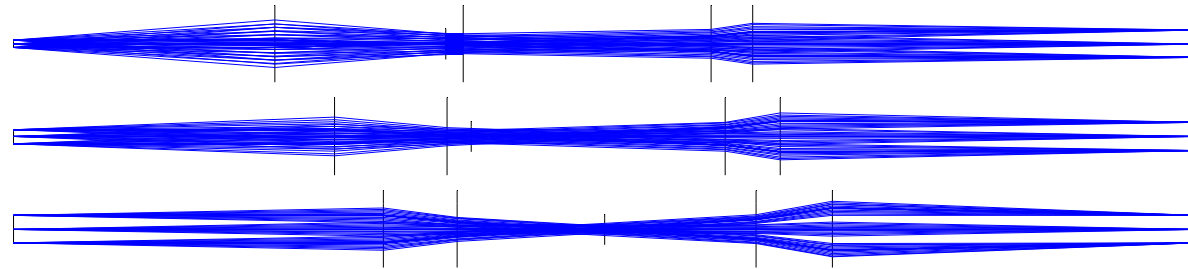

| | | 1Meg | 4Meg | | | | | | | | | |
|-------------|------------|-----------|----------|-------------------|---------------------|----------|--------------|---------------|-------------|-----------|-----------|-----------------|
| sensor size | | 9 | 15 | | | | | | | | | |
| pixel size | | 9 | 7.5 | | | | | | | | | |
| Config | System Mag | 1 Meg Mag | 4Meg Mag | Resolution pixels | Input Field 4M (mm) | Input f# | Front EFL mm | Limiting Ap > | Rear EFL mm | Output F# | spot size | Output Field mm |
| 1 | 1.0 | 1 | | 4 | 9.0 | 23.3 | 98.0 | 4.2 | 98.0 | 23.3 | 36.0 | 9 |
| 2 | 1.5 | | 1.00 | 4 | 10.0 | 12.9 | 65.3 | 5.0 | 98.0 | 19.4 | 30.0 | 15 |
| 3 | 2.0 | 2 | | 4 | 4.5 | 11.7 | 49.0 | 4.2 | 98.0 | 23.3 | 36.0 | 9 |
| 4 | 2.3 | | 1.53 | 4 | 6.5 | 8.4 | 42.6 | 5.0 | 98.0 | 19.4 | 30.0 | 15 |
| 5 | 3.0 | | 2.00 | 4 | 5.0 | 6.5 | 32.7 | 5.0 | 98.0 | 19.4 | 30.0 | 15 |
| 6 | 4.0 | 4 | | 4 | 2.3 | 5.8 | 24.5 | 4.2 | 98.0 | 23.3 | 36.0 | 9 |
| 7 | 5.0 | 5 | | 4 | 1.8 | 4.7 | 19.6 | 4.2 | 98.0 | 23.3 | 36.0 | 9 |
| 8 | 6.0 | | 4.00 | 4 | 2.5 | 3.2 | 16.3 | 5.0 | 98.0 | 19.4 | 30.0 | 15 |

Things to watch for:

- F/number
- Length
- Large clear aperture

System getting very fast

>F/7 may be possible to use off-the-shelf optics
 <F/7 custom solution likely
 < F/3 multi-elements, difficult
 Depends on aperture (larger = more difficult)

Special Considerations

- Necessary conditions for operation
 - Fringes temporally resolved
 - Vibration ($\Delta\text{OPD}(t) < 1/2f_{\text{max}}$)
 - Coherence ($\text{max OPD} < \text{coherence length}$)
 - Fringes spatially resolved ($\Lambda/2 > \text{pixel width}$)
 - Polarization (need common components at the detector)
 - Signal Level (Intensity balance of ref. and obj.)
- Other design considerations
 - Coherent interference from stray/multiple reflections
 - Non-common path aberrations (may be due to elements that appear to be common path)
 - Both pupil imaging and wavefront transfer must be considered
 - Polarization issues (birefringence, phase-shift on reflection)

Temporal and Spatial Resolution

Spatial Sampling

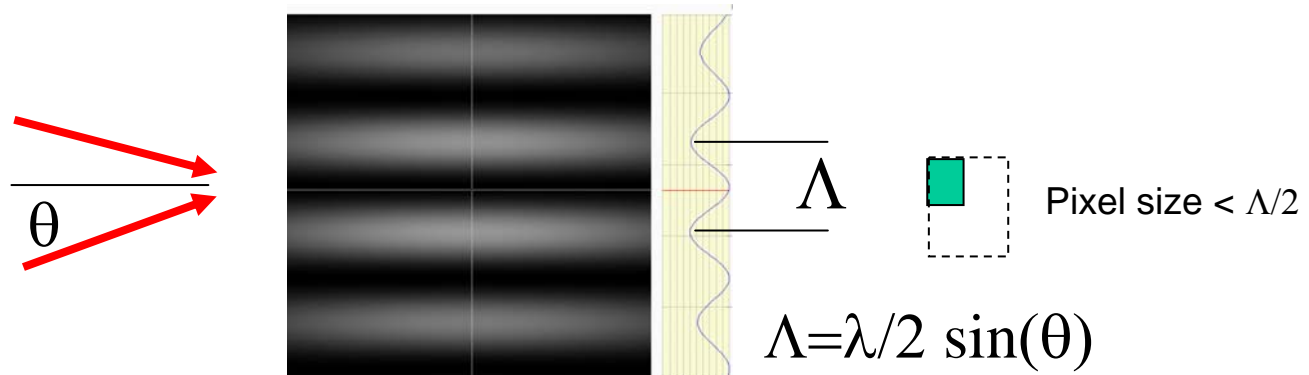

Temporal Sampling

$$I(t) = I \cos(2\pi f t)$$

$$BW > f_{max}$$

Analog system

$$T < 2/f_{max}$$

Discrete sampling

Stray Reflections

- Coherent Optical System

$$I_{\text{noise}} \sim \sqrt{I_{\text{signal}} I_{\text{stray}}} \quad (\text{incoherent } I_{\text{noise}} = I_{\text{stray}})$$

Stray from outgoing beam

$$I_{\text{stray(out)}} = I_{\text{out}} R$$

Stray from incoming beam

$$I_{\text{stray(inc)}} = I_{\text{signal}} * R^2$$

$$I_{\text{signal}} \sim 0.02 I_{\text{out}}$$

For 256:1 SN (8bits)

$$I_{\text{noise}} < I_{\text{signal}} / (256)$$

$$I_{\text{stray}} < I_{\text{signal}} / (256)^2$$

What happens if they focus?

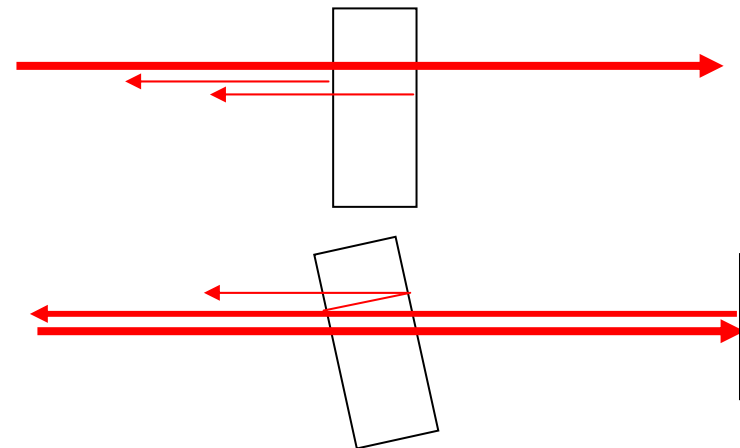

For outgoing

$R < 0.00003\%$ (Not possible!)

For incoming

$R < 0.4\%$ (possible but demanding)

Reducing Strays

1. Attenuation
 1. AR
 2. Absorption

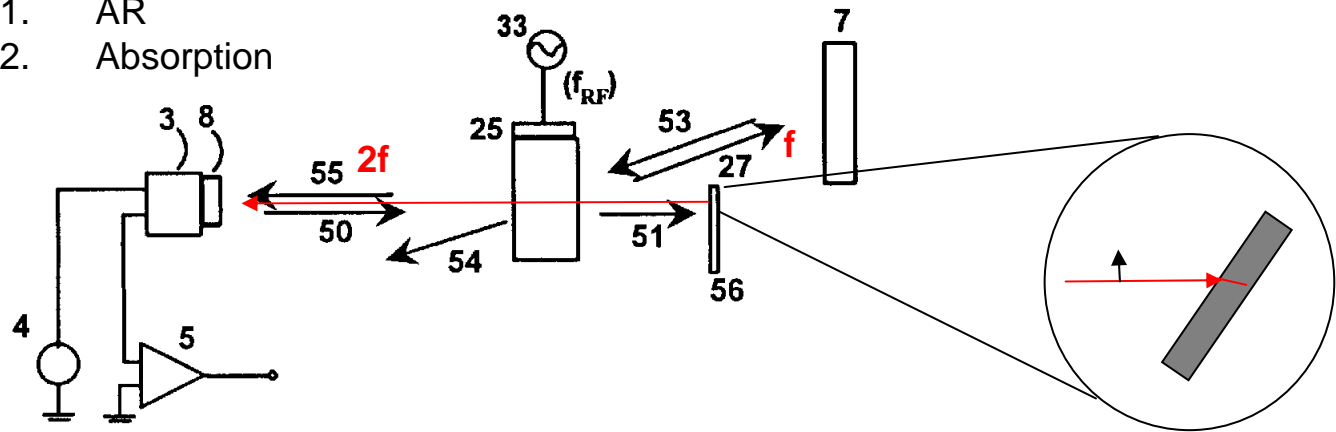

2. Walk off

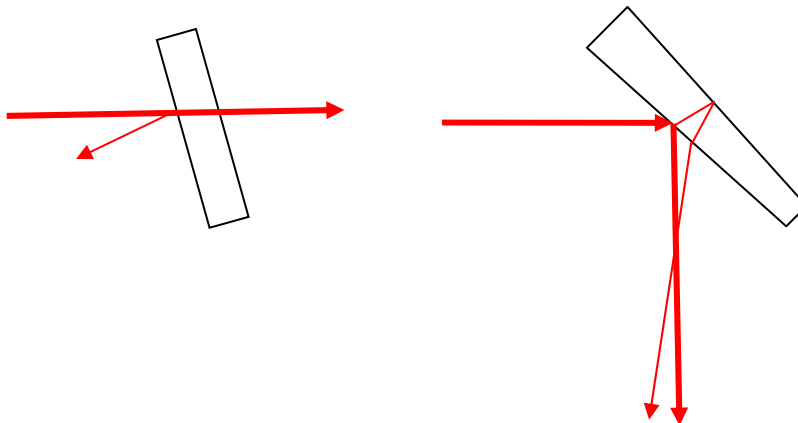

3. Eliminate surfaces



Phase shift on reflection

- A mirror can act like a waveplate
- Multiple mirrors will stack errors
- Collimated beam – piston error
- Diverging beam – radial error

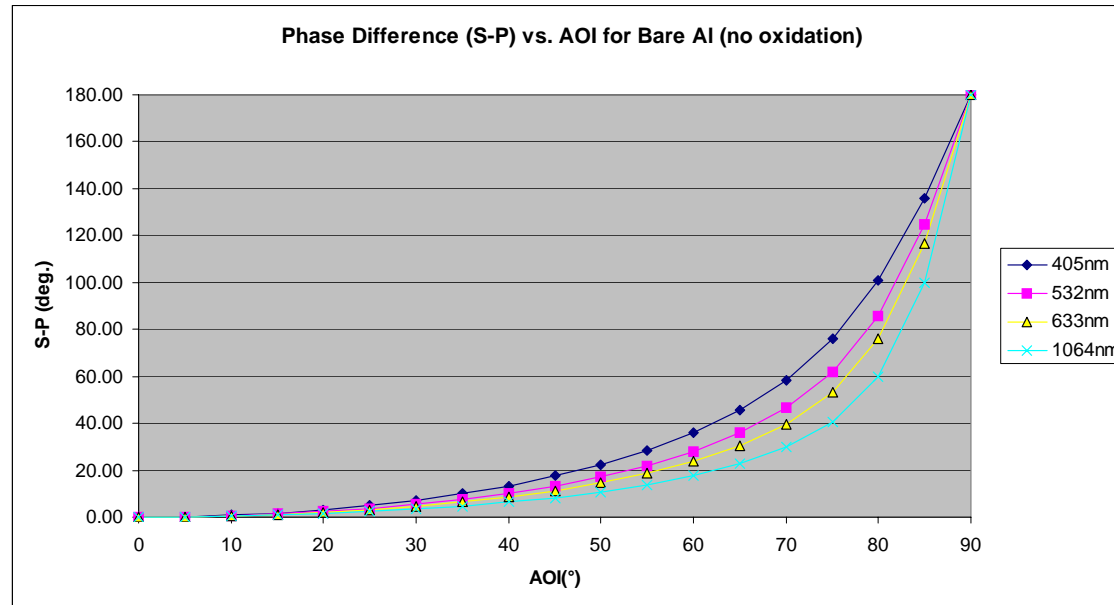
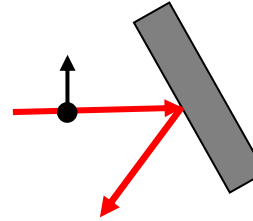

Detailed Design

- Zemax, Code V, Oslo, etc
- Often necessary to maintain multiple models
 - Imaging vs. wavefront
 - Wavelengths
 - Zoom configurations
- Possible to balance aberrations in different sections
 - Be careful of wavefront stack-up
- Also need to develop
 - Alignment plan (fiducials, adjustments, procedures, etc)
 - Test plan (how will you verify performance, calibrate the system)
 - Software, electrical requirements
- Keep detailed design and revision notes
 - This will be invaluable when you return to a design after many weeks, months or years.

Optical Models

- **Wavefront model**
- Collimated input
- Tilt between reference and object beam means non-common path

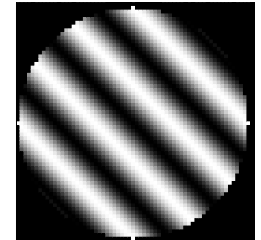
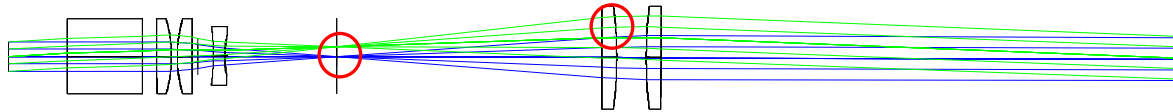

- **Imaging model**
- Field point sources
- Spot size, distortion, etc.

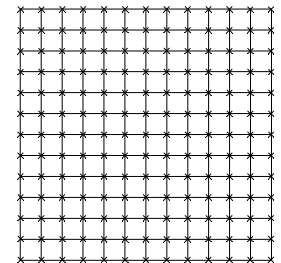
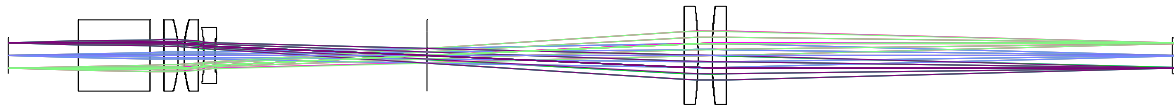

Optical Models (2)

Imaging Path may be different than wavefront model

- Multi-configs used to examine imaging over full range

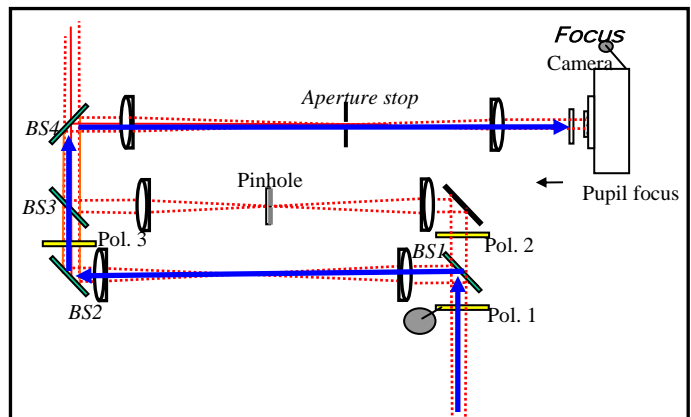
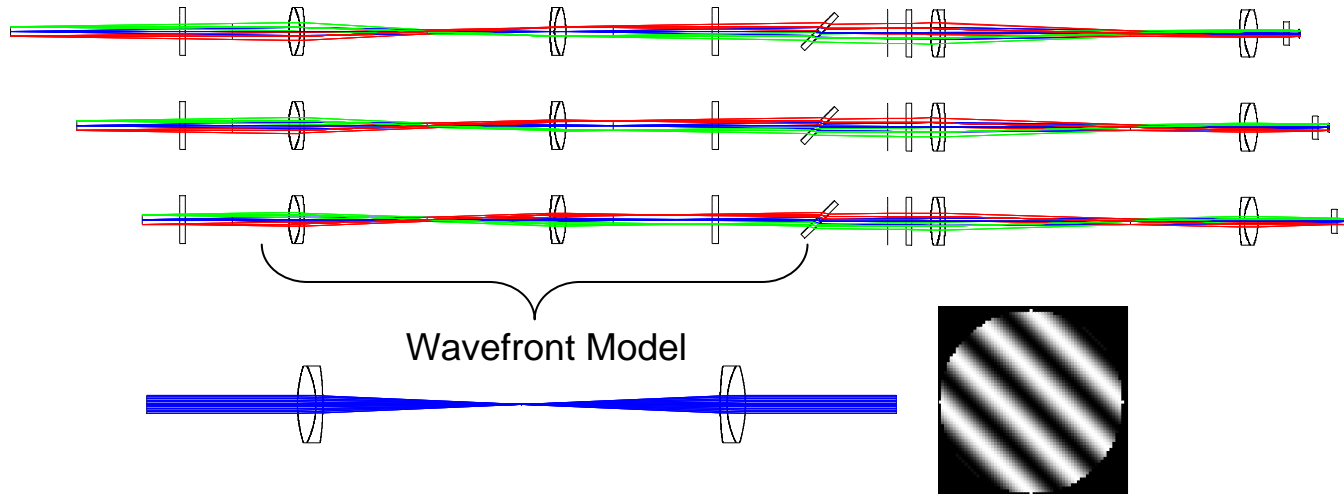

Optical Models (3)

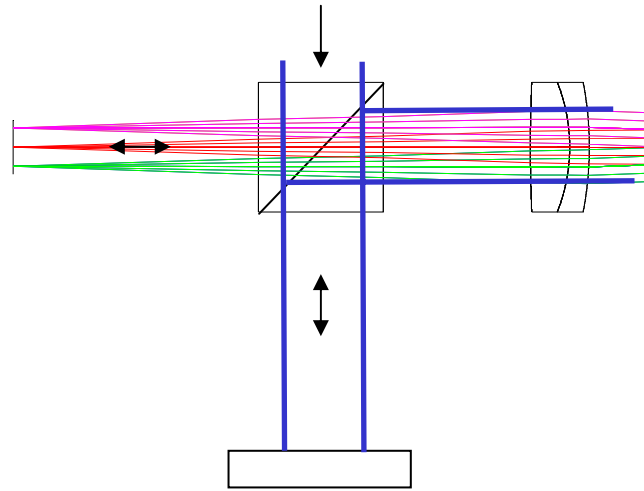

What changes in this setup?

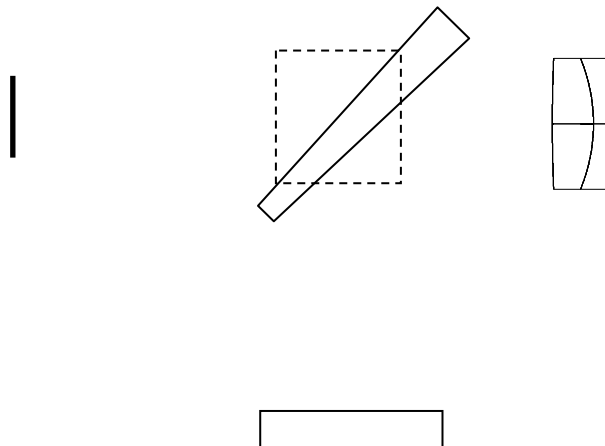

Tolerancing

- An optical design that meets optical performance spec is necessary but not sufficient.
 - The design must be fully toleranced to know if it can be built!
 - Can the design be:
 - built within budget,
 - aligned by a mortal, and
 - work over the desired environmental range?



Tolerancing approaches

- Steps to help arrive at a good final design
 - Including appropriate fields, wavelengths, and merit functions
 - Work closely with a mechanical engineer or machinist to understand what is doable and what is not.
 - Take advantage of fiducials and active adjustments during assembly to help reduce tolerance requirements

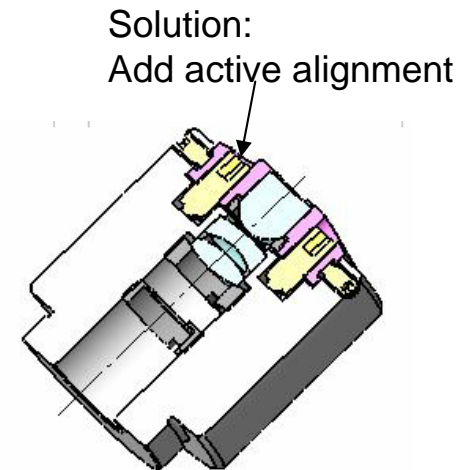
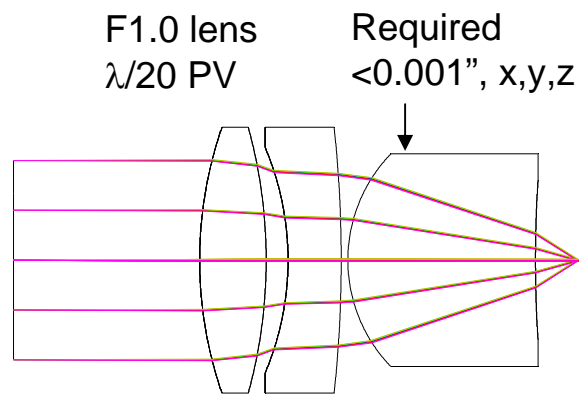

Adjustments, fiducials and procedures

Add adjustments judiciously

Too many: adds cost, complexity
 Too few: can't align the system

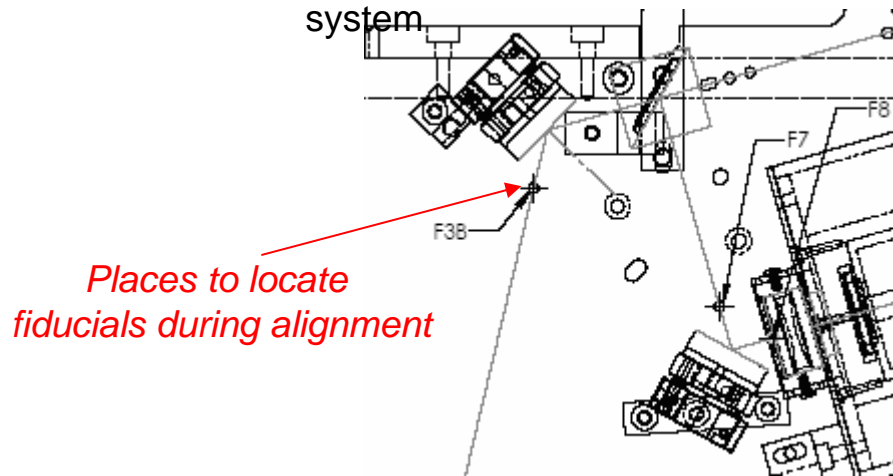

Add fiducials as necessary

Too many: over constrained
 Too few: can't align the system

Simple Fiducial

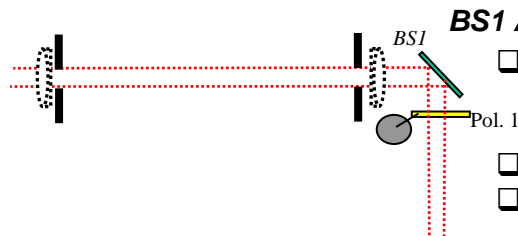

BS1 ALIGNMENT

- Place First Beam Splitter, BS1, 60% reflector
 - o HR side closest to input and Lens 1.
 - o Make sure the clock angle of the wedge is correct (Thick edge closest to Lens 1).
- Place iris in the position of the two lenses in the TEST leg
- Use x,y,z adjust on BS1 to pass the beam through both iris

Summary

- Optical design for a (good) interferometer is an involved process.
 - OE Must interact with a variety of disciplines to be successful
 - A working optical design is not sufficient, it needs to be buildable – Tolerancing!
 - Alignment and test must be considered during the design process
- Interferometers have special requirements
 - Multiple criteria must be satisfied for operation
 - Coherent interference (strays)
 - Wavefront quality and imaging must be considered
- Optical systems design is challenging but can be very rewarding (when you see your instrument work)!