



Night Vision Systems in Aviation

Captain Michel Lortie
Canadian Forces

6 Dec 06

OPTI 696BX

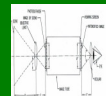

Outline

- How do they work ?
- Design Considerations
- Integration Issues

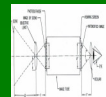

Understanding Night Vision

- NVG objective larger than eye
- NVG sensitive to wider spectrum
- Peak night radiance
- Electron Multiplication

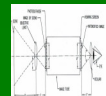
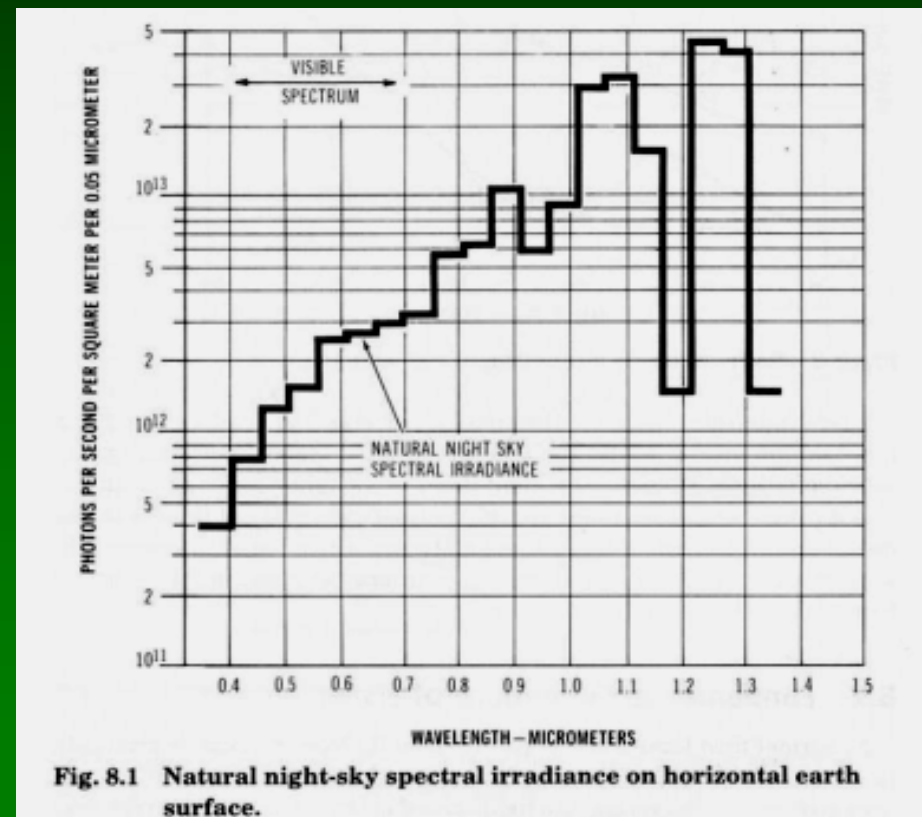

Understanding Night Vision

- NVG objective larger than eye
- NVG sensitive to wider spectrum
- Peak night radiance
- Electron Multiplication

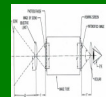
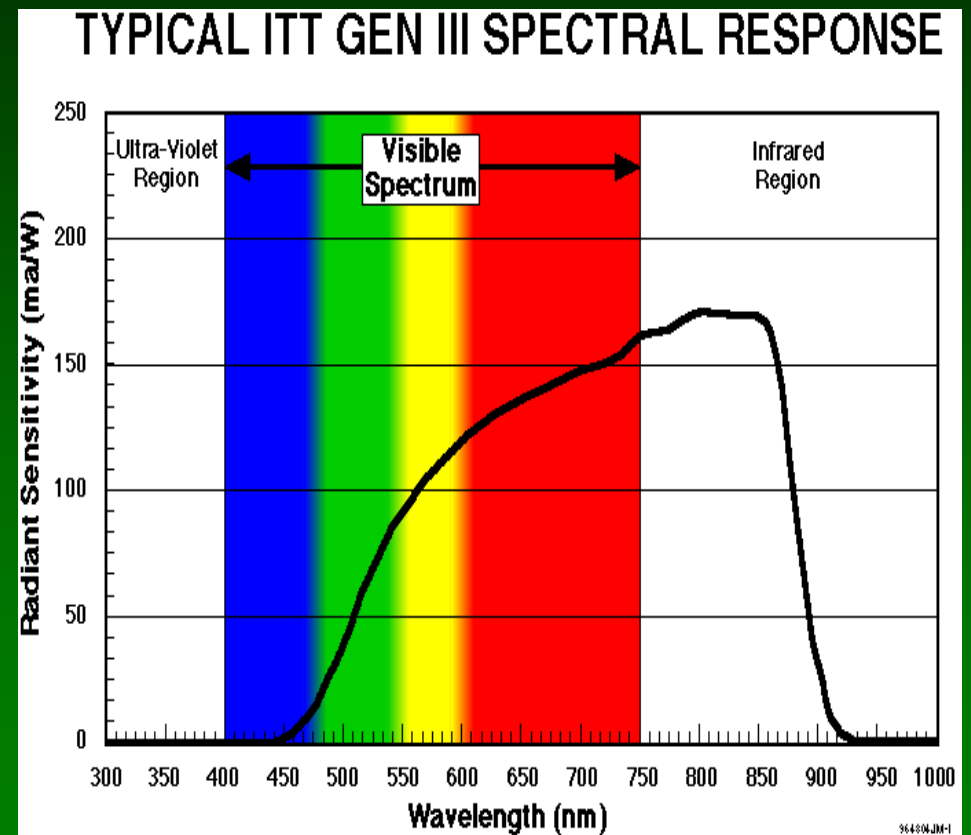

Night Vision Goggles

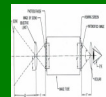
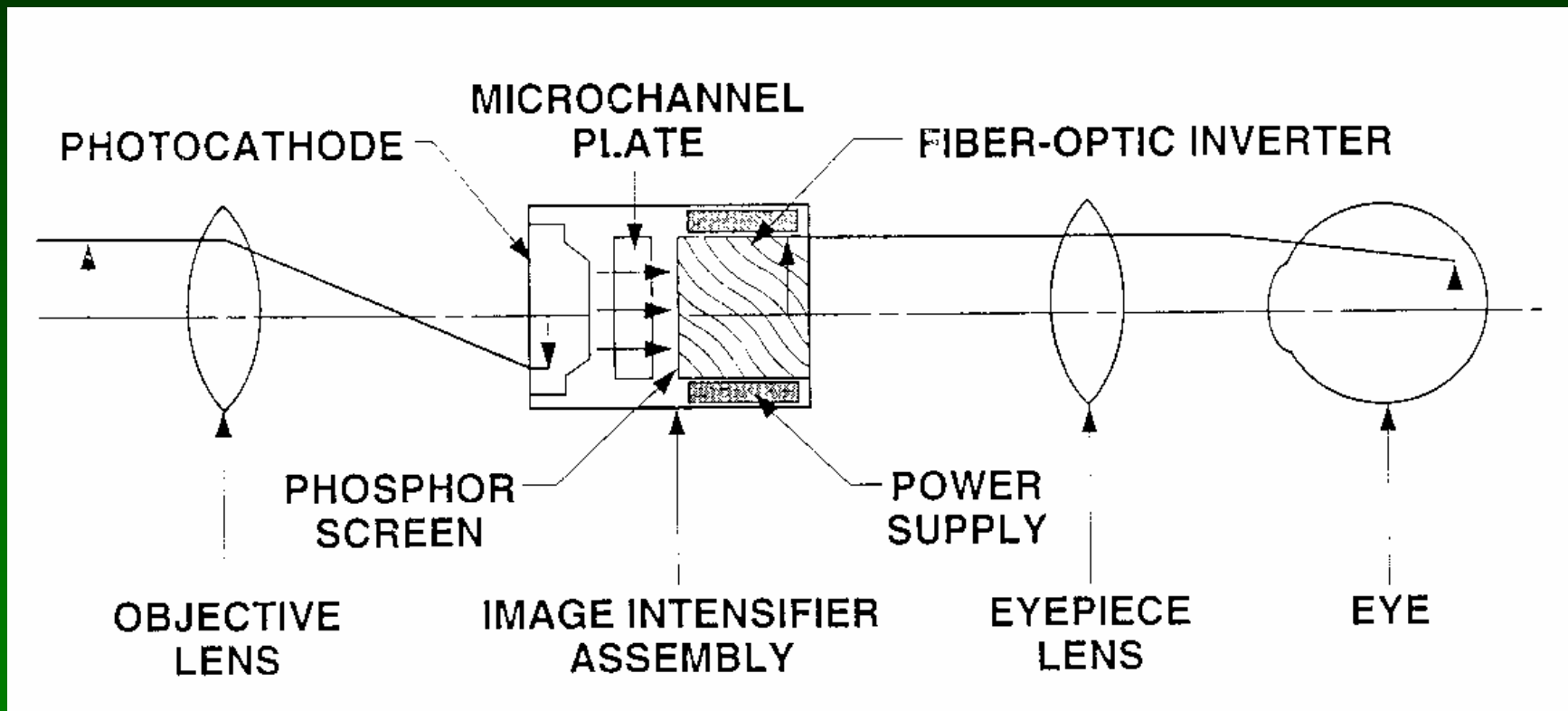
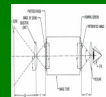
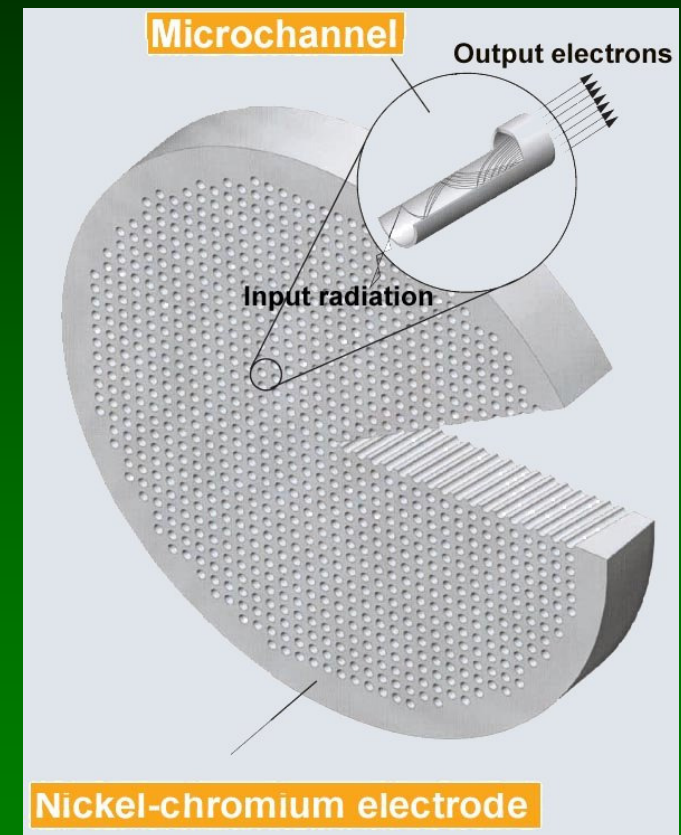

Image Intensifying Tubes

- Hollow fibers fused together together
- Amplifies signal
- Technological generations



Design Considerations

- 1 X Magnification
- Resolution limit- MCP
- Automatic Gain Control
- Compact Design

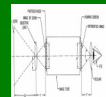
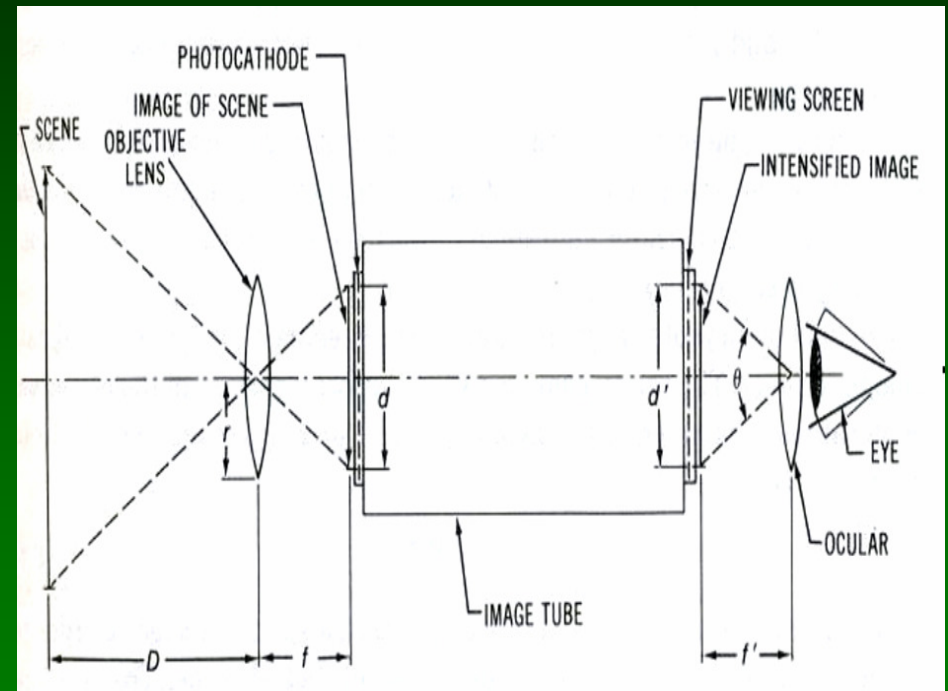

Design Considerations

- No vignetting
- Diopter Adjustment
- Redundancy

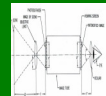
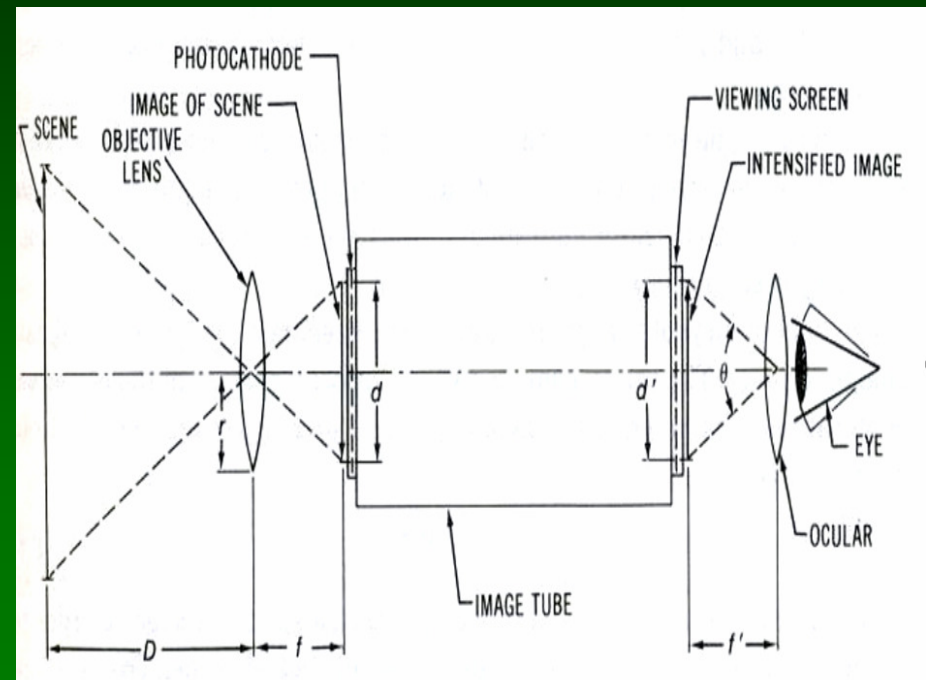

Performance Specs

- Sensitivity (1800 mA/Im^*)
- SNR (21^*)
- Resolution (64 lp/mm^*)

* State-of-the-art performance spec examples

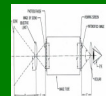

Problems

- Narrow FOV
- Low depth perception
- Inadequate illumination
- Vision through Fog/Snow/Smoke/Sand
- Noise
- Weight

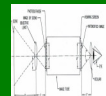

Outline

- How do they work ?
- Design Considerations
- Integration Issues

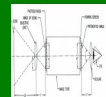

Spectral Response (no filter)

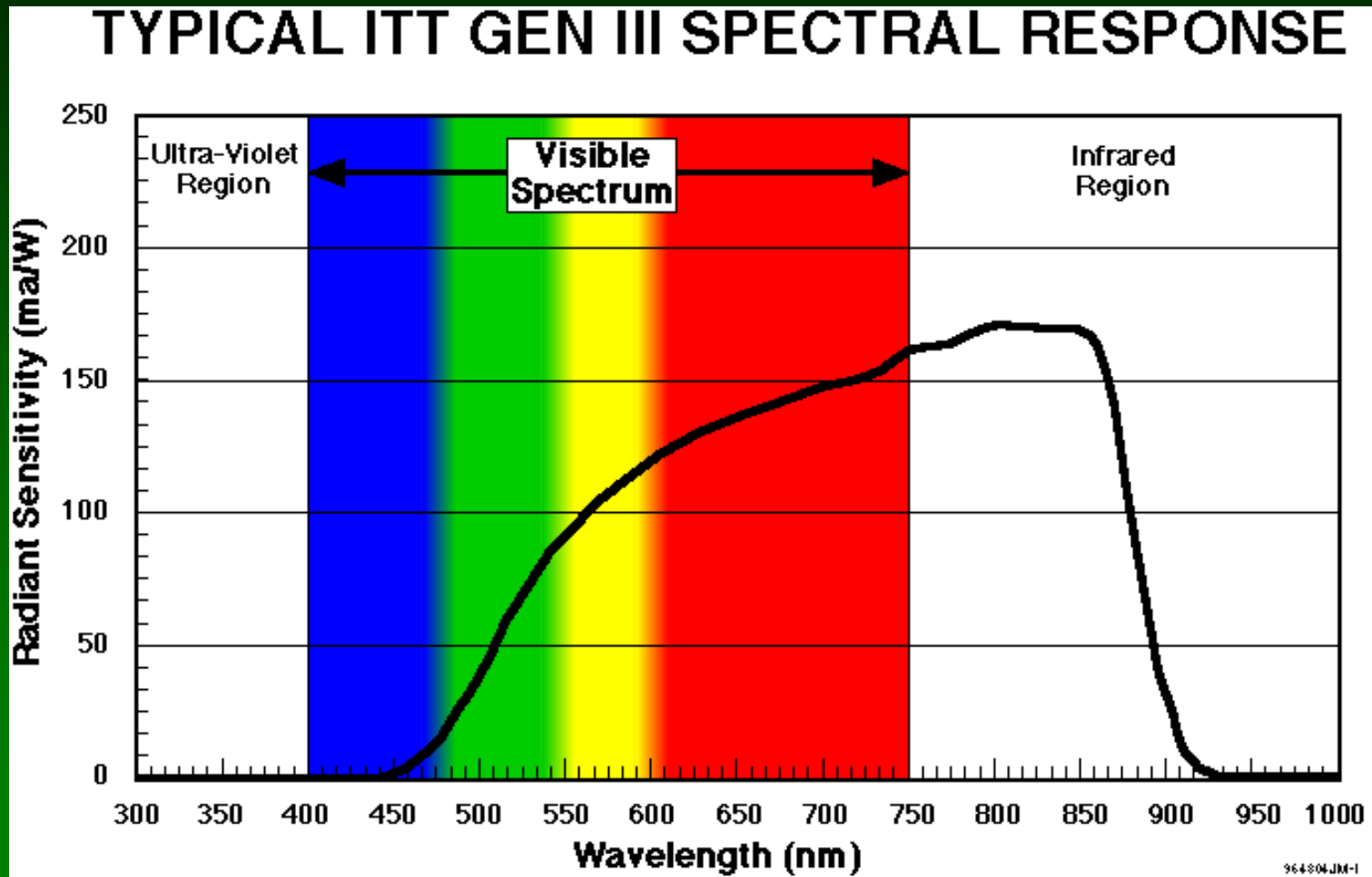

6 Dec 06

OPTI 696BX

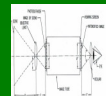

System Response (filtered)

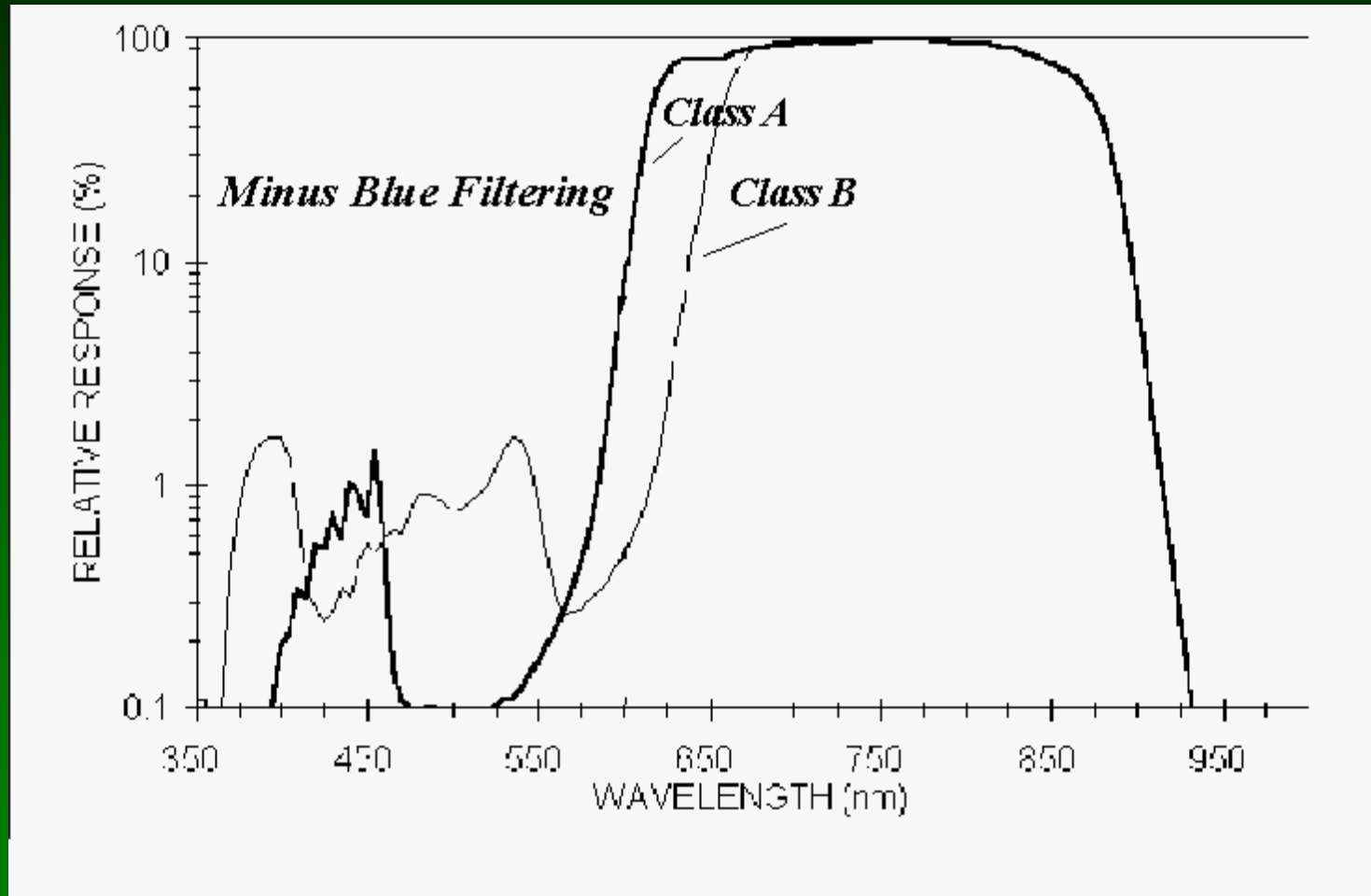

6 Dec 06

OPTI 696BX

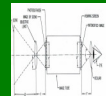

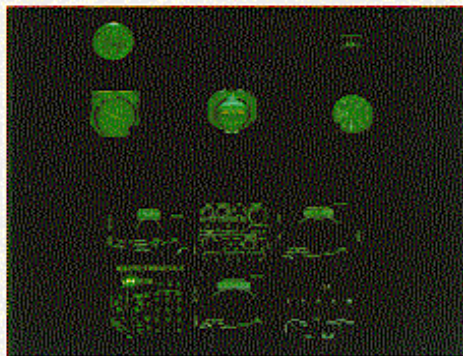

MIL-L-85762A-Compliant Instruments

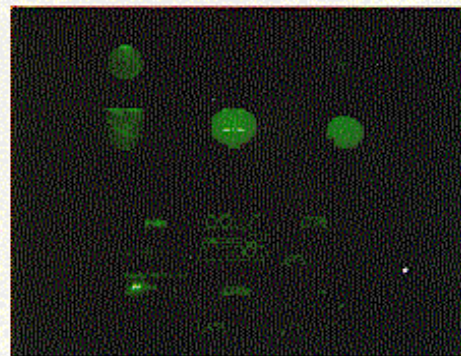

MIL-L-85762A Instruments through Gen III Night Vision Goggles

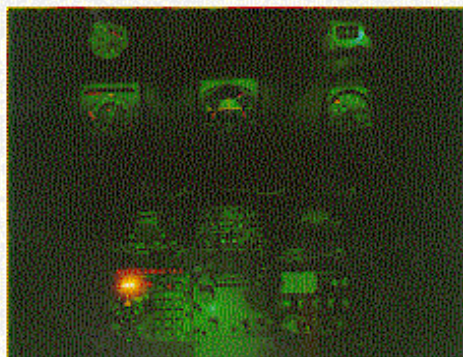

Night Vision Compatible Instruments

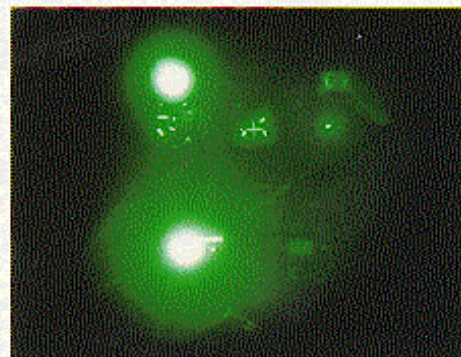

Night Vision Compatible Instruments through Gen III Night Vision Goggles

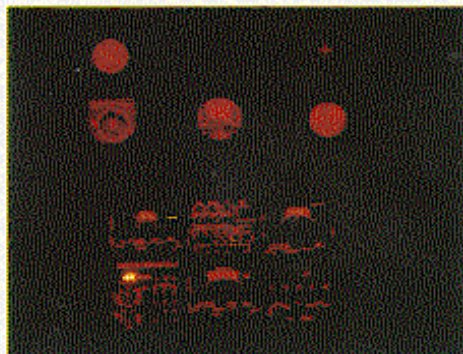

Standard Red Instruments



Standard Red Instruments through Gen III Night Vision Goggles

References

- <http://www.hec.afrl.af.mil/Publications/default.asp>
- www.SPIE.org
- Image Tubes, by Csorba (in Hopf library)

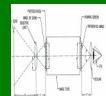



Questions?

6 Dec 06

OPTI 696BX

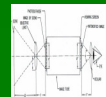

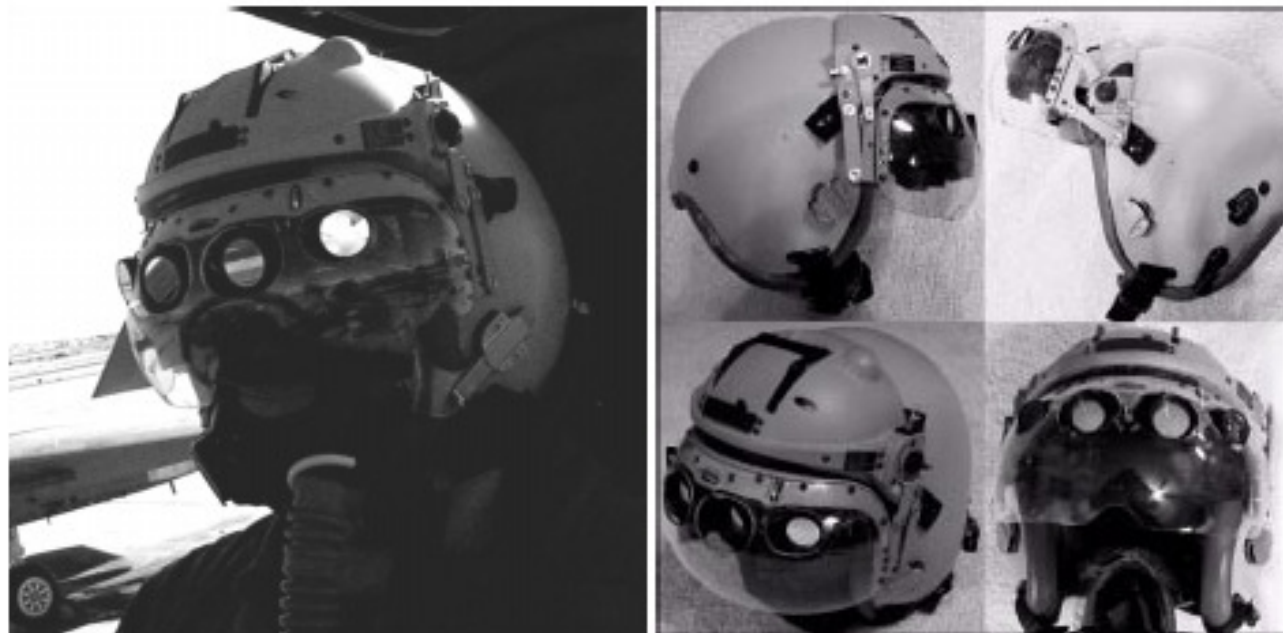
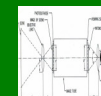
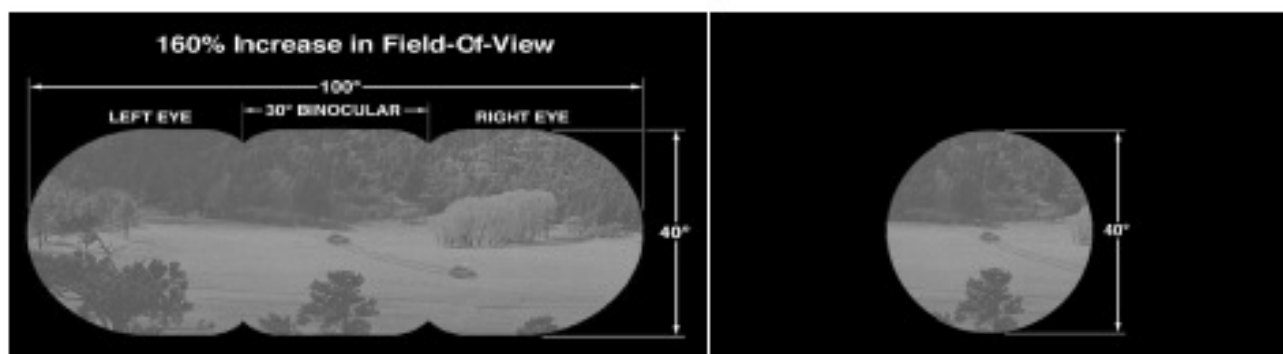
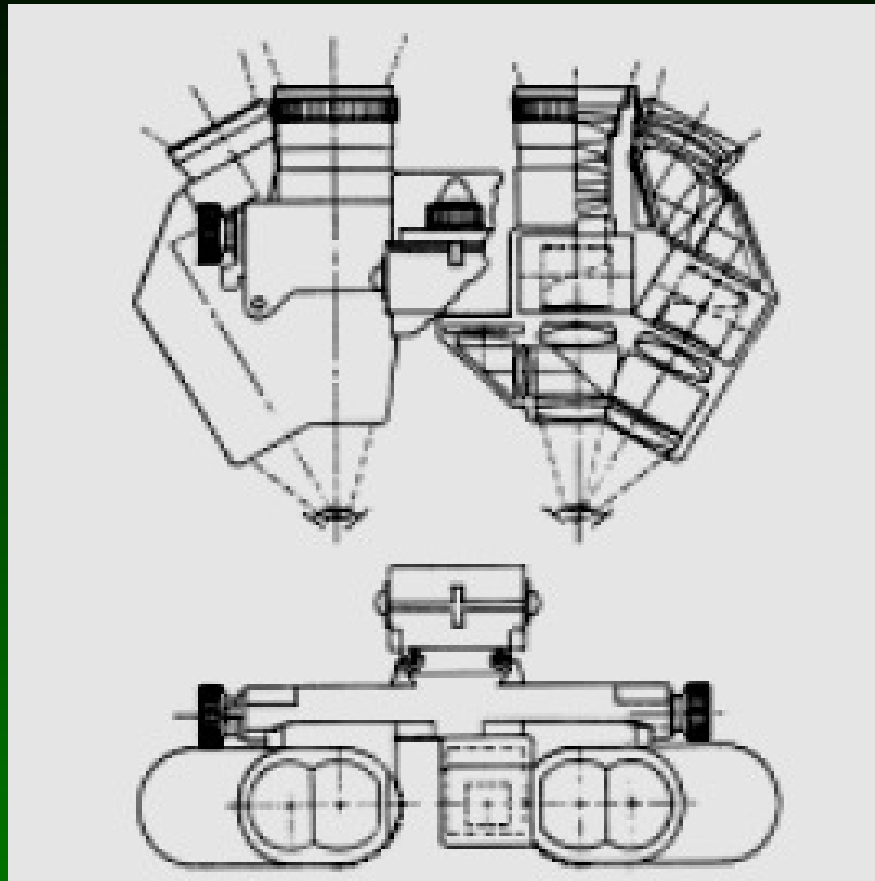

Figure 1. PNVG I, low profile design (Patent # 5,416,315, Other patents pending)





6 Dec 06

OPTI 696BX

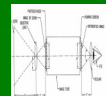

Table 8.2 Illumination Levels for Night and Daylight Conditions

Night Condition	Illumination (lm/m ²)	Photons/mm ² /s
overcast starlight	10 ⁻⁴	1.3 × 10 ⁶
starlight	10 ⁻³	1.3 × 10 ⁷
quarter moon	10 ⁻²	1.3 × 10 ⁸
full moon	10 ⁻¹	1.3 × 10 ⁹
deep twilight	1	1.3 × 10 ¹⁰
twilight	10	1.3 × 10 ¹¹
very dark day	10 ²	1.3 × 10 ¹²
overcast day	10 ³	1.3 × 10 ¹³
daylight	10 ⁴	1.3 × 10 ¹⁴
direct sunlight	10 ⁵	1.3 × 10 ¹⁵