

# 19. Threaded Fasteners

We use threaded fasteners (screws) to hold things together.

How are these specified?

What are the issues when choosing among different types of screws?

## How to specify fasteners

Inch								
Dia. (inch)		Threads per inch		Length (inch)	Drive Style	Head Style	Strength Level	Plating/Coating
3/4	-	10	X	5	Hex	Cap Screw	Grade 5	Zinc
3/4	-	16	X	5	Hex	Cap Screw	Grade 5	Zinc

Metric									
Dia. (mm)		Pitch (only if fine)		Length (mm)	Drive Style	Head Style	Strength Level	DIN No.	Plating/Coating
M8		X		25	Hex	Cap Screw	8.8	931 (partial thread)	Plain
								933 (full thread)	
M8	X	1	X	25	Hex	Cap Screw	8.8	960 (partial thread)	Plain
								961 (full thread)	

# Thread pitch

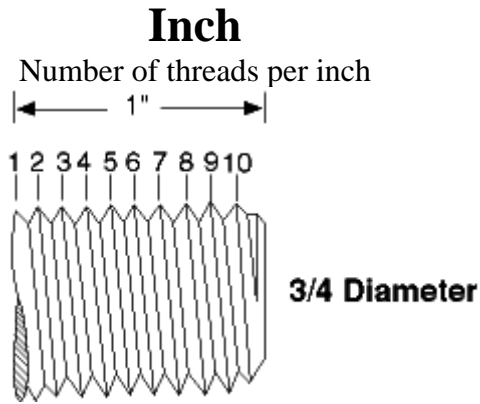

Diameter inches	Threads per inch	Type
3/4	- 10	= Coarse UNC
3/4	- 16	= Fine UNF

Diameter millimeters	Distance millimeters	Type
M8	X 1.25	= Coarse
M8	X 1	= Fine

## Pitch/diameter charts

Inch		
Diameter (inch)	Pitch	
	Coarse	Fine
No. 0 (.060")		80
No. 1 (.073")	64	72
No. 2 (.086")	56	64
No. 3 (.099")	48	56
No. 4 (.112")	40	48
No. 5 (.125")	40	44
No. 6 (.138")	32	40
No. 8 (.164")	32	36
*No. 10 (.190")	24	32
No. 12 (.216")	24	28
1/4	20	28
5/16	18	24
3/8	16	24
7/16	14	20
1/2	13	20
9/16	12	18
5/8	11	18
3/4	10	16
7/8	9	14
1	8	14
1 1/8	7	12
1 1/4	7	12
1 1/2	6	12
1 3/4	5	
2 in.	4 1/2	
2 1/4	4 1/2	
2 1/2	4	
2 3/4	4	
3	4	

\* Equivalent to 3/16

Metric		
Most Common		
Diameter (mm)	Pitch	
	Coarse	Fine
1	0.25	
1.2	0.25	
1.6	0.35	
2	0.4	
2.5	0.45	
3	0.5	
4	0.7	
5	0.8	
6	1	
8	1.25	1
10	1.5	1 (1.25)
12	1.75	1.25 (1.5)
16	2	1.5
20	2.5	1.5
24	3	2
30	3.5	2
36	4	3
42	4.5	3
48	5	3
56	5.5	4
64	6	4
72		6
80		6
90		6
100		6

Metric		
Not Popular		
Diameter (mm)	Pitch	
	Coarse	Fine
1.4	0.3	
1.8	0.35	
2.2	0.45	
3.5	0.6	
14	2	1.5
18	2.5	1.5
22	2.5	1.5
27	3	2
33	3.5	2
45	4.5	3
52	5	3
60	5.5	4
68	6	4
76		6
85		6
95		6

Special Applications		
Diameter (mm)	Pitch	
	Coarse	Fine
7	1	
11	1.5	1
15		1
25		1.5
26		1.5
28		2
39	4	3

**Note:** To determine the tap drill size for metric fasteners, simply subtract thread pitch from the fastener diameter and drop all but the first decimal place.

Example: M12 - 1.75 = 10.25 is a 10.2 tap drill size

## Drills and taps for common threads

Gage and Fractional Sizes	Major diam. (inches)	Clearance Drill	UNC tpi	Tap Drill for UNC	UNF tpi	Tap Drill for UNF	Nut Size
0	0.0600	#52	—	—	80	$\frac{3}{64}$ "	$\frac{5}{32}$ "
2	0.0860	#43	56	#50	64	#50	$\frac{3}{16}$ "
4	0.1120	#32	40	#43	48	#42	$\frac{1}{4}$ "
6	0.1380	#27	32	#36	40	#33	$\frac{5}{16}$ "
8	0.1640	#18	32	#29	36	#29	$1\frac{1}{32}$ "
10	0.190	#9	24	#25	32	#21	$\frac{3}{8}$ "
$\frac{1}{4}$ "	0.2500	F	20	#7	28	#3	$\frac{7}{16}$ "
$\frac{5}{16}$ "	0.3125	P	18	F	24	I	$\frac{9}{16}$ "
$\frac{3}{8}$ "	0.375	W	16	$\frac{5}{16}$ "	24	Q	$\frac{5}{8}$ "
$\frac{7}{16}$ "	0.4375	$29\frac{1}{64}$ "	14	U	20	$25\frac{1}{64}$ "	
$\frac{1}{2}$ "	0.5000	$33\frac{1}{64}$ "	13	$27\frac{1}{64}$ "	20	$29\frac{1}{64}$ "	$\frac{3}{4}$ "
$\frac{9}{16}$ "	0.5625	$\frac{9}{16}$ "	12	$31\frac{1}{64}$ "	18	$33\frac{1}{64}$ "	
$\frac{5}{8}$ "	0.6250	$\frac{5}{8}$ "	11	$17\frac{1}{32}$ "	18	$37\frac{1}{64}$ "	
$\frac{3}{4}$ "	0.7500	$\frac{3}{4}$ "	10	$21\frac{1}{32}$ "	16		$1\frac{1}{8}$ "
$\frac{7}{8}$ "	0.8750	$\frac{7}{8}$ "	9	$49\frac{1}{64}$ "	14		$1\frac{5}{16}$ "
1"	1.0000	1"	8	$\frac{7}{8}$ "	14		$1\frac{1}{2}$ "

# Common head styles



**Round**  
(Metric n/a)



**Pan**



**Flat**



**Oval**



**Fillister**  
(Metric – Cheese)



**Truss**

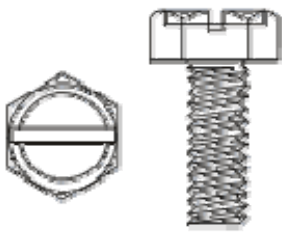

**Slotted Ind. Hex**

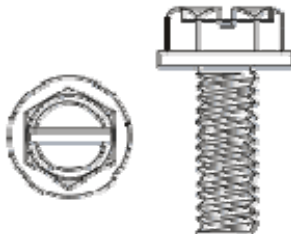

**Slotted Ind. Hex Washer**

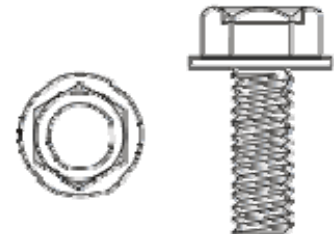

**Ind. Hex Washer**

## Drive Types

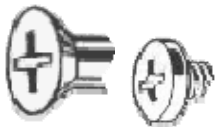

**Phillips and Frearson**  
An X shaped drive.  
Abbreviated PH

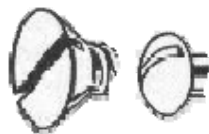

**Slotted**  
A slot in the head.  
Abbreviated SL



**Combination**  
A combination of slotted  
and Phillips drives.  
Abbreviated Combo

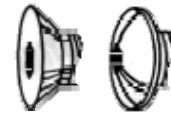

**Socket or Allen**  
A hexagonal hole for use  
with an Allen wrench.

(Ref McMaster-Carr)

## Socket head cap screw basics

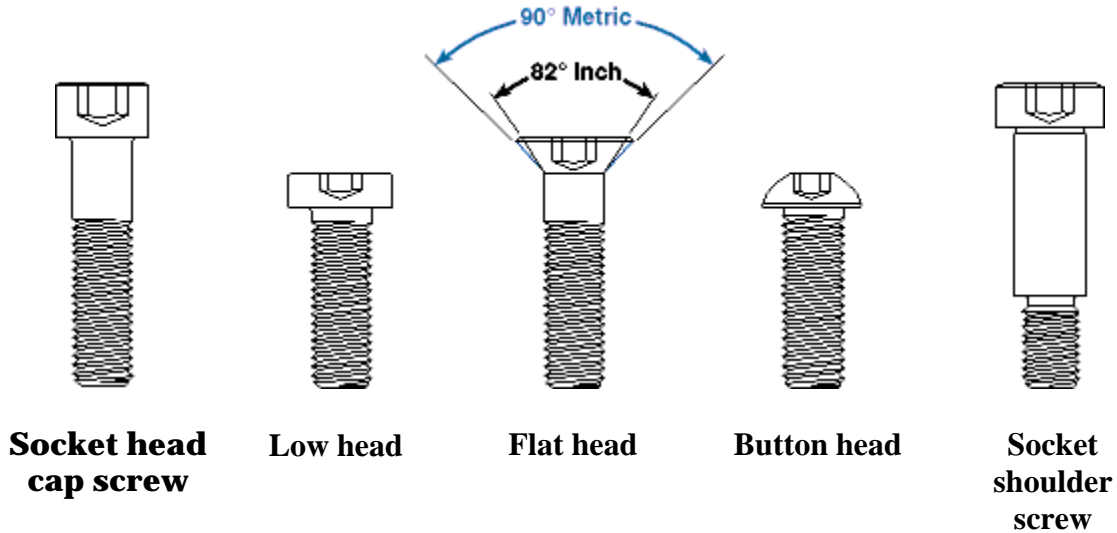

### Socket Head Cap Screw - strongest of all head style.

- Head height is equal to shank diameter.
- Shouldn't be mated with a regular hex nut, which isn't as strong.

### Low Head Cap Screw - designed for applications with head height limitations

- Head height is approximately half the shank diameter.

### Flat Head Cap Screw - for flush applications

Caution: Inch and metric have different countersink angles. Mismatching fastener and hole countersink angles can result in premature fastener failure

### Button Head Cap Screw

- Larger head diameter makes it more appropriate for holding thin materials like sheet metal guards.
- Because of its internal hex drive style it's ideal for tamper-proofing applications.
- Good substitute for other drive styles that are prone to stripping like Phillips and slotted.

### Socket Shoulder Screw

- Typically used as a pivot point or axle because shoulders are ground to a tight tolerance.

## Thread Class

- Socket head cap screws 1" diameter and under have class 3A fit (tight tolerance). Over 1" have a class 2A fit (typical hex cap tolerance).
- All other head styles and diameters have a class 3A fit.

## Specifications

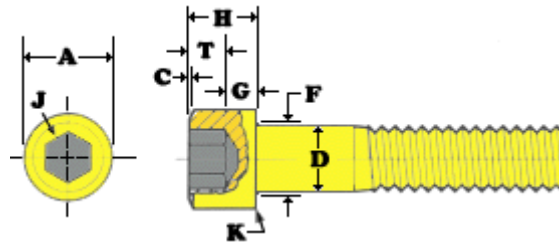

### Head and Body Dimensions - Alloy and Stainless - ASME B18.3-1998 - Includes 1960 Series

Screw Diam.	D	A	H	C	J	F	T	G	K				
	Body Diameter	Head Diameter	Head Height	Top Chamfer or Radius	Hex Socket Size	Fillet Transition Diameter	Key Engagement	Wall Thickness	Bottom Chamfer or Radius				
0	.0600	.0568	.0960	.091	.060	.057	.004	.050	.074	.063	.025	.020	.007
1	.0730	.0695	.118	.112	.073	.070	.005	1/16	.087	.076	.031	.025	.007
2	.0860	.0822	.140	.134	.086	.083	.008	5/64	.102	.090	.038	.029	.007
3	.0990	.0949	.161	.154	.099	.095	.008	5/64	.115	.103	.044	.034	.007
4	.1120	.1075	.183	.176	.112	.108	.009	3/32	.130	.118	.051	.038	.008
5	.1250	.1202	.205	.198	.125	.121	.012	3/32	.145	.132	.057	.043	.008
6	.138	.1329	.226	.218	.138	.134	.013	7/64	.158	.145	.064	.047	.008
8	.1640	.1585	.270	.262	.164	.159	.014	9/64	.188	.173	.077	.056	.008
10	.1900	.1840	.312	.303	.190	.185	.018	5/32	.218	.202	.090	.065	.008
1/4	.2500	.2435	.375	.365	.250	.244	.025	3/16	.278	.262	.120	.095	.010
5/16	.3125	.3053	.469	.457	.312	.306	.033	1/4	.347	.329	.151	.119	.010
3/8	.3750	.3678	.562	.550	.375	.368	.040	4/15	.415	.398	.182	.143	.010
7/16	.4375	.4294	.656	.642	.438	.430	.047	3/8	.484	.465	.213	.166	.015
1/2	.5000	.4919	.750	.735	.500	.492	.055	3/8	.552	.532	.245	.190	.015
5/8	.6250	.6163	.938	.921	.625	.616	.070	1/2	.689	.664	.307	.238	.015
3/4	.7500	.7406	1.125	1.107	.750	.740	.085	5/8	.828	.801	.370	.285	.015
7/8	.8750	.8647	1.312	1.293	.875	.864	.100	3/4	.963	.933	.432	.333	.020
1	1.0000	.9886	1.500	1.479	1.000	.988	.114	3/4	1.100	1.069	.495	.380	.020
1-1/4	1.2500	1.2336	1.875	1.852	1.250	1.236	.144	7/8	1.370	1.334	.620	.475	.020
1-1/2	1.5000	1.4818	2.250	2.224	1.500	1.485	.176	1	1.640	1.602	.745	.570	.020

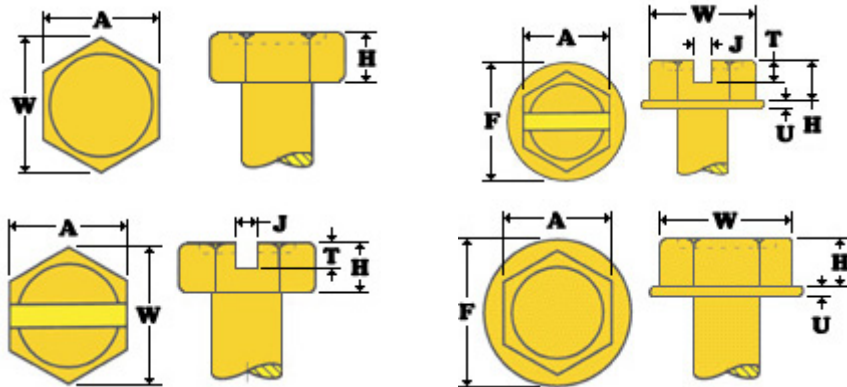

### Head Dimensions Hex Head and Hex Washer Head Machine Screws - ANSI B18.6.3

Nominal Size	A		W	H		F		U		J		T	
	Width Across Flats		Width Across Corners	Head Height		Washer Diameter		Washer Thickness		Slot Width		Slot Depth	
	Max	Min	Min	Max	Min	Max	Min	Max	Min	Max	Min	Max	Min
4	.188	.181	.202	.060	.049	.243	.225	.019	.011	.039	.031	.042	.025
5	.188	.181	.202	.070	.058	.260	.240	.025	.015	.043	.035	.049	.030
6	.250	.244	.272	.093	.080	.328	.302	.025	.015	.048	.039	.053	.033
8	.250	.244	.272	.110	.096	.348	.322	.031	.019	.054	.045	.074	.052
10	.312	.305	.340	.120	.105	.414	.384	.031	.019	.060	.050	.080	.057
12	.312	.305	.340	.155	.139	.432	.398	.039	.022	.067	.056	.103	.077
1/4	.375	.367	.409	.190	.172	.520	.480	.050	.030	.075	.064	.111	.083
5/16	.500	.489	.545	.230	.208	.676	.624	.055	.035	.084	.072	.134	.100
3/8	.562	.551	.614	.295	.270	.780	.720	.063	.037	.094	.081	.168	.131

# Strength of fasteners

Inch				Metric			
Grade	Head Marking	For Inch Diameters	Tensile Strength <sup>1</sup> (PSI)	Property Class	Head Marking	For Metric Diameters	Tensile Strength (PSI) <sup>2</sup>
2	No marking	1/4 - 3/4	74,000 PSI	5.6	 or For M5 and above	M12 - M24	72,500 PSI
		7/8 - 1 1/2	60,000 PSI				
5		1/4 - 1	120,000 PSI	8.8	 or For M5 and above	M17 - M36	120,350 PSI
		over 1 - 1 1/2	105,000 PSI				
8		1/4 - 1 1/2	150,000 PSI	10.9	 or For M5 and above	M6 - M36	150,800 PSI

1 Amount of force required to pull apart fastener

2 Converted from megapascals (MPa) PSI/145 = MPa or MPa x 145 = PSI

## Inch

- **Grade** indicates strength level in the **inch** system.
- When specifying inch fastener strengths, call them out as grades.

## Metric

- **Property class** indicates strength level in the **metric** system.
- When specifying metric fastener strengths, call them out as property classes. Don't confusingly ask for a metric Grade 8 hex cap screw. Ask for a metric property class 10.9 instead.

**Warning:** Similar numbers used for grade and property class designations **don't stand for the same** strength. For example, a Grade 8 hex cap screw and a property class 8.8 hex cap screw have different tensile strengths. See table.

## Suggested Tightening Torque Values to Produce Corresponding Bolt Clamping Loads

			SAE Grade 2 Bolts			SAE Grade 5 Bolts			SAE Grade 8 bolts		
			74 ksi tensile strength			120 ksi tensile strength			150 ksi tensile strength		
			55 ksi proof load			85 ksi proof load			120 ksi proof load		
Size	Bolt Diam. D(in.)	Stress Area A(in <sup>2</sup> )	Clamp Load P (lb)	Torque Dry in-lb	Torque Lubed in-lb	Clamp Load P (lb)	Torque Dry In-lb	Torque Lubed in-lb	Clamp Load P (lb)	Torque Dry in-lb	Torque Lubed in-lb
4-40	0.1120	.00604	240	5	4	380	8	6	540	12	9
4-48	0.1120	.00661	280	6	5	420	9	7	600	13	10
6-32	0.1380	.00909	380	10	8	580	16	12	820	23	17
6-40	0.1380	.01015	420	12	9	640	18	13	920	25	19
8-32	0.1640	.01400	580	19	14	900	30	22	1260	41	31
8-36	0.1640	.01474	600	20	15	940	31	23	1320	43	32
10-24	0.1900	.01750	720	27	21	1120	43	32	1580	60	45
10-32	0.1900	.02000	820	31	23	1285	49	36	1800	68	51
1/4-20	0.2500	0.0318	1320	66	49	2020	96	75	2860	144	108
1/4-28	0.2500	0.0364	1500	76	56	2320	120	86	3280	168	120
5/16-18	0.3125	0.0524	2160	11	8	3340	17	13	4720	25	18
5/16-24	0.3125	0.0580	2400	12	9	3700	19	14	5220	25	20
3/8-16	0.3750	0.0775	3200	20	15	4940	30	23	7000	45	35
3/8-24	0.3750	0.0878	3620	23	17	5600	35	25	7900	50	35
7/16-14	0.4375	0.1063	4380	30	24	6800	50	35	9550	70	55
7/16-20	0.4375	0.1187	4900	35	25	7550	55	40	10700	80	60
1/2-13	0.5000	0.1419	5840	50	35	9050	75	55	12750	110	80
1/2-13	0.5000	0.1599	6600	55	40	10700	90	65	14400	120	90
9/16-12	0.5625	0.1820	7500	70	55	11600	110	80	16400	150	110
9/16-18	0.5625	0.2030	8400	80	60	12950	120	90	18250	170	130
5/8-11	0.6250	0.2260	9300	100	75	14400	150	110	20350	220	170
5/8-18	0.6250	0.2560	10600	110	85	16300	170	130	23000	240	180
3/4-10	0.7500	0.3340	13800	175	130	21300	260	200	30100	380	280
3/4-16	0.7500	0.3730	15400	195	145	23800	300	220	33600	420	320

### Notes:

1. Tightening torque values are calculated from the formula  $T = KDP$ , where  $T$  = tightening torque, lb-in.  $K$  = torque-friction coefficient;  $D$  = nominal bolt diameter, in; and  $P$  = bolt clamp load developed by tightening, lb.
2. Clamp load is also known as preload or initial load in tension on bolt. Clamp load (lb) is calculated by arbitrarily assuming usable bolt strength is 75% of bolt proof load (psi) times tensile stress area (sq in.) of threaded section of each bolt size. Higher or lower values of clamp load can be used depending on the application requirements and the judgement of the designer.

## Strength of threads

Shear stress is total force/engaged area

Rules of thumb:

Engage screws into threads over length 1.5 x the diameter

Root diameter = screw diameter – thread spacing

Shear strength = ultimate strength/sqrt(3) (using Von Mises strength)

Example: 1/4-20 grade 2 screw threaded into Aluminum

For nominal 1320 lb clamp load

<p><u>Strength of Al threads</u>                  For engaged length <math>L = 0.37</math> in                  Mean diameter <math>D_r = 1/4 - (1/20)/2 = 0.225</math>"                  Engaged area = <math>\pi * D * L = 0.26</math> in<sup>2</sup>                  Shear stress = <math>1320 \text{ lb} / 0.26 \text{ in}^2 = 5080</math> psi                  Ultimate strength of aluminum = 42 ksi                  Yield strength is 35 ksi                  Shear strength = <math>35 \text{ ksi} / 1.73 = 20</math> ksi.                  Safety factor of <math>23/5.1 = 4</math></p>	<p><u>Strength of screw:</u>                  Root diameter <math>D_r = 0.25 - 1/20 = 0.2</math>"  <math>A = \pi D_r^2 / 4 = 0.031</math> in<sup>2</sup>                  Stress = <math>1320 \text{ lb} / 0.031 = 43</math> ksi                  Ultimate strength for grade 2 bolt is 74 ksi                  Proof load strength is 55 ksi                  Safety factor of <math>55/43 = 1.8</math></p>
-----------------------------------------------------------------------------------------------------------------------------------------------------------------------------------------------------------------------------------------------------------------------------------------------------------------------------------------------------------------------------------------------------------------------------------------------------------------------------------------------------------------------------------------------------------------------------------------------------------------------------------	--------------------------------------------------------------------------------------------------------------------------------------------------------------------------------------------------------------------------------------------------------------------------------------------------------------------------------------------------------------------------------------------------------------------------------------

### The threads are stronger than the screw

More detailed method of establishing strength is given in the appendix

#### Threaded inserts:

Threads in soft materials are easily damaged

Strength can be significantly improved

##### Helical Inserts



Repair threads in any material with these corrosion-resistant coil inserts. Includes helical inserts, screw-lock helical inserts, and tangles helical inserts.

##### Threaded Inserts for Metals



These threaded inserts are ideal for quick, permanent repair for stripped threads in stainless steel and other metals.

##### Threaded Inserts for Plastics and Wood



Includes threaded inserts for thermoplastics, expansion inserts, knife-thread inserts, knurled press inserts, press-fit inserts, tee nuts, and knock-in inserts.

**Bolted joints:**

**Strength comes from fastener.**

**Stiffness comes from assembly**

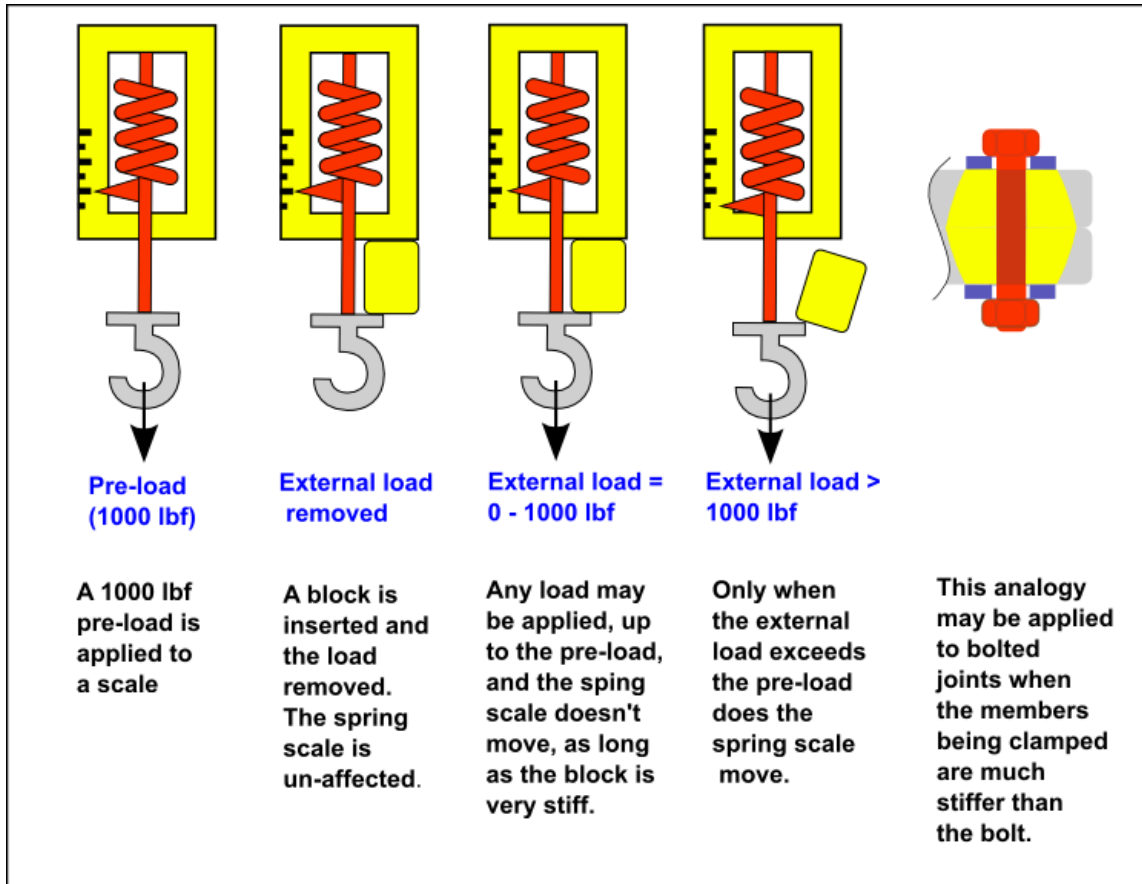



## About Socket Cap Screw Materials

Finish/Coating	Features
<b>Plain</b>	Good for general purpose applications.
<b>Zinc-Plated</b>	Provides excellent corrosion resistance.
<b>Cadmium-Plated</b>	Offers better rust resistance than zinc-plating, especially in salt environments.
<b>Nickel-Chrome Plated</b>	Polished and buffed to a bright, mirror-like finish. Resists wear and corrosion.
<b>Black-Oxide</b>	Offers mild rust resistance and some lubrication qualities.
<b>Blue-Coated</b>	This highly visible blue coating makes it easier to distinguish metric from inch sizes.
<b>Ultra Corrosion-Resistant Coated</b>	Also known as armor coat. Provides better corrosion resistance than zinc, cadmium, and hot-dipped galvanized plating. The thickness of the coating does not interfere with the thread fit.
Material Type	Features
<b>Plain Steel</b>	Good for general purpose applications.
<b>18-8 Stainless Steel</b>	Provides excellent corrosion resistance. May be mildly magnetic.
<b>300 Series Stainless Steel</b>	Meet more stringent specifications such as military specifications. Corrosion Resistant.
<b>316 Stainless Steel</b>	Offers excellent corrosion resistance, even more than 18-8 stainless steel. Contains molybdenum which increases corrosion resistance to chlorides and phosphates.
<b>Bumax 88 Stainless Steel</b>	316L stainless steel with a high molybdenum content offering corrosion resistance similar to 316 stainless steel. May be mildly magnetic.
<b>Brass</b>	Nonmagnetic and softer than stainless steel and mild steel.
<b>Nylon 6/6</b>	Nonconductive and resistant to chemicals and solvents (except mineral acids). Since nylon absorbs moisture from the environment, changes in moisture content will affect the fastener's dimensions and properties. Withstands a wide range of temperatures.
<b>Silicon Bronze</b>	Made of 95-98% copper with a small amount of silicon for strength. Nonmagnetic and offers high thermal conductivity and corrosion resistance.
<b>A286 Super Alloy</b>	Made of 26% nickel and 15% chrome with corrosion resistance similar to 18-8 stainless steel and strength properties comparable to alloy steel. Is considered an iron-based super alloy. Passivated (a nitric acid treatment that creates a passive film to protect against oxidation and corrosion).

---

**McMASTER-CARR**

---

## Washers

- Distribute load from screw head
- Protect surface from screw head
- Keep screw from backing out
- Take up space (shim)
- Act as a spring
- Provide sealing

### Shape



# Appendix

## Guide to Specifying Torque Values for Fasteners

Note : The following notes are given as a guide only. It is recommended that torque values derived from formulae should not be used without comparison to figures obtained using practical tests.

### Introduction

Generally, in the majority of applications, the reliability of the joint is dependent upon the bolt's ability to clamp the parts together. Adequate clamping prevents relative motion between parts of the joint and leakage from joints containing gaskets. Measuring a bolt's clamp force is difficult, especially under production assembly conditions. The clamp force generated by a bolt can be indirectly controlled by regulating the applied torque. The method, known as **Torque Control**, is by far the most popular method of controlling a bolt's clamp force. The initial clamp force generated by the bolt is frequently called **Preload**.

There is a link between the torque applied to a bolt and the resulting preload. A problem exists because friction has a large influence on how much torque is converted into preload. Besides the torque required to stretch the bolt, torque is also required to overcome friction in the threads and under the nut face. Typically, only 10% to 15% of the torque is used to stretch the bolt. Of the remaining torque, typically 30% is dissipated in the threads and 50% to 55% under the nut face. Because friction is such an important factor in the relationship between torque and preload, variations in friction have a significant influence on the bolt's preload. Different bolt surface finishes generally have different friction values. The torque required for a socket headed screw will not be the same as that required for the same size hexagon bolt. The larger bearing face of the standard bolt will result in increased torque being required compared to a socket headed screw. This is because more torque is being dissipated between the nut face and the joint surface.

### Stresses induced into a bolt

When a bolt is tightened, the shank and thread sustain a direct (tensile) stress due to it being stretched. In addition, a torsion stress is induced due to the torque acting on the threads. These two stresses are combined into a single equivalent stress to allow a comparison to be made to the bolt's yield strength. In order to effectively utilize the strength of the bolt, yet leave some margin for any loading the bolt would sustain in service, an equivalent stress of 90% of yield is commonly used. This approach is used in this guide.

This approach has a number of advantages over the method where a direct stress, and hence preload value, is assumed in the bolt. For high thread friction values, a high torsion stress results in the bolt. Less of the available strength of the bolt is being utilized in such a case to generate preload. In the extreme case when a nut has seized on the bolt thread, all the applied torque is sustained as torsion stress with no preload being available. In the other extreme, low thread friction results in higher preloads.

Note : The following information is provided to assist Engineers wishing to establish the theoretical torque value for a particular fastener. Caution should be exercised when using theoretical values because the preload and torque is dependant upon the friction values selected.

### Calculation Procedure

The formulae used are applicable to metric and unified thread forms which have a thread flank angle of 60°. The calculation procedure distinguishes between thread and underhead friction as well as differences which can be caused by bearing face diameter variations.

The procedure comprises of the following steps;

#### 1. Fastener Details

Dimensions and strength grades are specified in various standards.

Strength Grade	3.6	4.6	4.8	5.6	5.8	6.8	8.8	9.8	10.9	12.9
* Yield Stress N/mm <sup>2</sup>	180	240	320	300	400	480	640 #	720	900	1080

*\* Nominal values quoted. # For grades 8.8 and above a proof stress is specified because of problems measuring yield. BS 6104 Pt. 1*

Table 1 presents information on strength grades of bolts; the most common grade for metric fasteners is grade 8.8.

Estimating the appropriate friction coefficient can be problematic.

External Steel Threads	Internal Self Finish Steel Threads	Internal Zinc Plated Steel Threads	Internal Cast Iron Threads	Internal Aluminium Threads
<b>Dry Self Finish or Phosphate Treated</b>	0.10 to 0.16	0.12 to 0.18	0.10 to 0.16	0.10 to 0.20
<b>Oiled Self Finish or Phosphate Treated</b>	0.08 to 0.16	0.10 to 0.18	0.08 to 0.18	0.10 to 0.18
<b>Dry Zinc Plated</b>	0.12 to 0.20	0.12 to 0.22	0.10 to 0.17	0.12 to 0.20
<b>Oiled Zinc Plated</b>	0.10 to 0.18	0.10 to 0.18	0.10 to 0.16	0.10 to 0.18
<b>Thread Adhesive</b>	0.18 to 0.24	0.18 to 0.24	0.18 to 0.24	0.18 to 0.24

Tables 2 and 3 may be used as a guide when other information is not available.

Condition of the Bolt Head or Nut	Zinc Plated Steel part clamped by Bolt	Self Finish Steel part clamped by Bolt	Cast Iron part clamped by Bolt	Aluminum part clamped by Bolt
Dry Zinc Plated Finish	0.16 to 0.22	0.10 to 0.20	0.10 to 0.20	-
Slight Oil Applied to Zinc Plated Finish	0.10 to 0.18	0.10 to 0.18	0.10 to 0.18	-
Dry Self Finish or Phosphate or Black Oxide Finish	0.10 to 0.18	0.10 to 0.18	0.08 to 0.16	-
Slight Oil Applied to a Self Finish or Phosphate or Black Oxide Finish	0.10 to 0.18	0.10 to 0.18	0.12 to 0.20	0.08 to 0.20

*Gaps in table indicate a lack of available published data.*

## 2. Determination of the tensile stress in the threaded section.

To determine the tensile stress in the fastener, first establish what proportion of the yield strength you wish the tightening process to utilise. Normally a figure of 90% is acceptable but may be varied to suit the application. Because of the torque being applied to the threads, torsion reduces the tensile stress available to generate preload. The following formula can be used to determine the tensile stress in the thread.

$$\sigma_T = \frac{\sigma_B}{\sqrt{\left[ 1 + 3 \times \left\{ \left( \frac{4 \times d_2}{d_1 + d_3} \right) \times \left( \left[ \frac{P}{11 \times d_1} \right] + [1155 \times A_T] \right) \right\}^2 \right]}}$$

## 3. Establish the preload

The preload F is related to the direct tensile stress  $\sigma_T$  by :

$$F = A_s \times \sigma_T$$

The stress area of the thread  $A_s$  represents the effective section of the thread. It is based upon the mean of the thread pitch and minor diameters. It can be obtained from tables or calculated using the formula:

$$A_s = \frac{\pi \times (d_3 + d_1)^2}{15}$$

## 4. Determine the tightening torque.

The relationship between tightening torque T and bolt preload F is:

$$T = F \times \left[ (0.159 \times P) + (0.577 \times d_2 \times \mu_T) + \left( D_f \times \frac{\mu_H}{2} \right) \right]$$

If units of Newton's and millimeters are being used, T will be in N.mm. To convert to N.m, divide the value by 1000.

The effective friction diameter  $D_f$  can be determined using the following formula:

$$D_f = \frac{(D_0 + D_i)}{2}$$

For a standard hexagon headed nut,  $D_0$  is usually taken as the across flats dimension and  $D_i$  as the diameter of bolts clearance hole.

**Note : Use of friction values**

As can be seen from tables 2 and 3, upper and lower limits to friction values are stated. Traditionally a mean value of friction is used when calculating the tightening torque and preload value. Be aware however, that for other conditions remaining constant, the higher the value of friction - higher is the required tightening torque and lower is the resulting preload.

<b>Terms used in the formulae</b>	
T	Tightening torque to be applied to the fastener.
F	The preload (or clamp force) in the fastener.
$\sigma_E$	Equivalent stress (combined tensile and torsion stress) in the bolt thread. A figure of 90% of the yield of proof stress of the fastener is usual.
$\sigma_T$	Tensile stress in the fastener.
$d_2$	Pitch diameter of the thread.
$d_3$	Minor (or root) diameter of the thread.
P	Pitch of the thread.
$\mu_T$	Thread friction coefficient.
$\mu_H$	Friction coefficient between the joint and nut face.
$D_f$	The effective friction diameter of the bolt head or nut.
$D_0$	Outside diameter of the nut bearing surface.
$D_i$	Inside diameter of the nut bearing surface.

**Example Calculation**

As an example, the above formulae will be used to determine the preload and tightening torque for a grade 8.8 M16 hexagon headed bolt.

**Step 1**

Establishing the dimensions and friction conditions. The data below is to be used.

$d_2 = 14.701 \text{ mm}$   
 $d_3 = 13.546 \text{ mm}$   
 $P = 2 \text{ mm}$   
 $\mu_T$  Taken as 0.11  
 $\mu_H$  Taken as 0.16

### **Step 2**

Calculating the tensile stress in the fastener using 90% of  $640 \text{ N/mm}^2$  gives  $\sigma_T = 576 \text{ N/mm}^2$ , substituting values into the formula gives;

$$\sigma_T = 491 \text{ N/mm}^2.$$

### **Step 3**

Taking the stress area as  $A_s$  as  $157 \text{ mm}^2$ , gives the bolt preload  $F$  to be  $77087\text{N}$ .

### **Step 4**

Determination of the tightening torque  $T$ .

*i*) The effective friction diameter. Taking  $D_o = 24 \text{ mm}$  and  $D_i = 17.27 \text{ mm}$  gives  $D_f = 20.6 \text{ mm}$ .

*ii*) Using the values calculated gives a tightening torque  **$T$  of  $223481$** , that is  **$223 \text{ Nm}$** .