

## 21. Motion control : Stages

Motion controls can be treated as:

- **Stages**  
These are expected to be exercised many times
- **Adjustments**  
These are expected to be made few times. Hopefully only once

Types of stages:

- Linear translation
- Rotation
- Tilt
- Multi-axis

Most stages control a single degree of freedom (control axis) at a time.

Any stage has a few key components:

- System of constraints  
This allows motion in the desired degree of freedom, yet constrains motion for other directions.
- Actuator  
This causes the motion in the desired degree of freedom. The actuator can be driven electrically or manually. The coupling from the actuator is important.
- Encoder  
This measures the amount of motion in the control axis. Sometimes the actuator itself provides this.

## Example: linear stage



### System of constraints

The carriage rides along two parallel rails. These allow motion in one direction only. The quality of the stage will determine motion accuracy:

Roll, pitch, yaw, vertical and lateral straightness.

### Actuator

A stepper motor is used to turn a screw. A nut fixed to the carriage converts this to linear motion. The precision of the motion depends on the motor and coupling.

### Encoder

A linear encoder is mounted to the side of the stage. This measures position of the carriage along the rails. The accuracy of this measurement is limited by the encoder and by coupling of stage wobble to the measurement.

“Abbe offset error”

## Abbe offset error

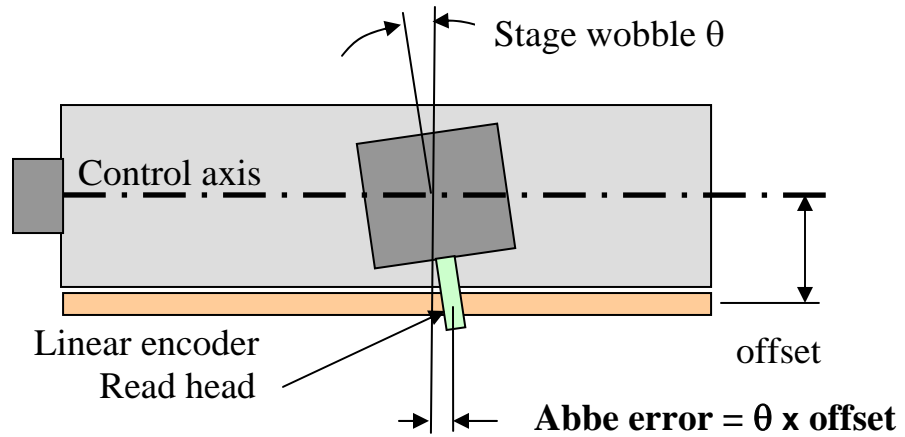

Improve this by:

- Minimize the offset : use distance measuring interferometer
- Minimize the wobble (spend more \$\$\$)
- Measure the angle AND the displacement and make a correction

## **General concerns with any type of stage**

### Resolution or repeatability of motion

Motion resolution, which can be quantified as step size or repeatability is usually important. You can't expect control any finer than this. The resolution can be limited by many things:

- resolution in the actuator
- friction from the bearings coupled with drive system compliance
- backlash

### Encoding accuracy

Encoding accuracy may be important. This is a function of the details of the encoder and its coupling. This is not the same as resolution. It can be many times better or many times worse. The accuracy can be limited by many things:

- encoder accuracy and resolution
- encoder calibration and its instability
- problems with the encoder (losing counts, initialization)
- compliance or slop in the encoder coupling
- Abbe offset error

### Errors in motion

The constraints, usually some form of bearing, will have errors.

For linear stages:

Roll, pitch, and yaw angular errors  
dx, dy departure from linear travel

For rotary stages

Wobble: angular error  
Radial and axial runout, displacement errors

For tilt stages

Cross-talk between axes

### Load capacity

The effects of loading are very important.

- The resolution usually depends on friction which is a strong function of loading.
- The bearings are sized according to load. It is expensive to maintain low friction for large loads. If you overload a bearing, you will damage it.

•  
**General concerns with any type of stage (continued)**

Stiffness

The stiffness of the stage can be very important. As loading changes, you need to maintain dimensional accuracy.

- Most bearings exhibit very low stiffness for light loading. The system stiffness is greatly increased by pre-loading with some sort of spring loading.
- Keep in mind all modes of compliance: three axes of translation and three for rotation

Stability

For precision applications, the stability is also important. Small stages use kinematic principles. Larger stages use kinematic concepts to avoid overconstraint, but they cannot maintain strict kinematics.

Some stages have separate locking mechanisms. These need to be carefully designed or the act of locking causes a shift.

Overtravel protection

Remotely driven stages can be driven too far. Electrical limit switches should be installed to protect the system

Maximum/minimum velocity

Sensitivity to environment

Especially contamination  
Vacuum

**Motion control - Translation stages -**  
(Newport)

*a) Dovetail Slide*

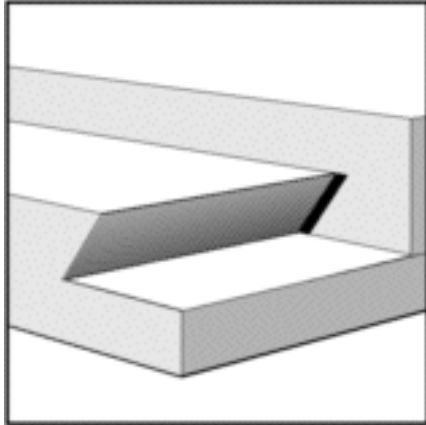

*b) Ball Bearing slide*

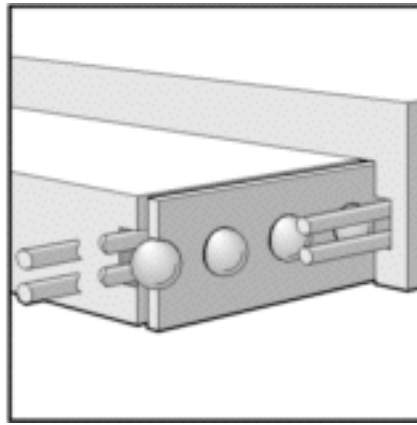



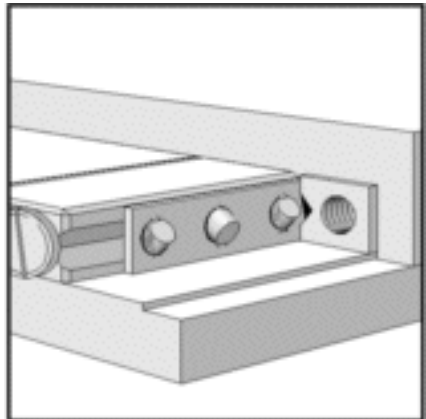

*c) Crossed Roller Bearing*

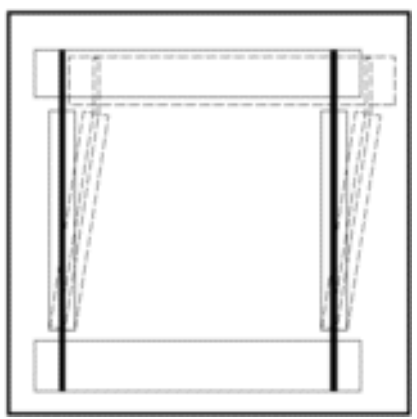

*d) Flexure*



Parameter	Dovetail 	Ball Bearing 	Crossed Roller Bearing 	Flexure 
<b>Cost</b>	Low	Moderate	High	Moderate to High
<b>Friction</b>	High (.25-.35)	Low (.002)	Low (.003)	None
<b>Stiffness</b>	High	Low	High	High
<b>Range of Motion</b>	Large	Moderate (<400mm)	Moderate (<400mm)	Small (1-2mm)
<b>Shock Resistance</b>	High	Low	Moderate	High
<b>Load Capacity</b>	High	Low	High	High
<b>Immunity to Contamination</b>	High	Moderate	Low	Very High
<b>Typical Application</b>	Focus/Course Positioning	General purpose micropositioning	Fiber optics alignment	Fiber optics alignment

The performance of a translation or rotation stage is primarily determined by the type of bearings which are used. Four major types will be considered: dovetail slides, ball bearings, crossed roller bearings, and flexure suspensions.

Dovetail slides are the simplest type of linear translation stages. They consist of two flat surfaces sliding against each other with the geometry shown in Figure 8. Dovetail slides can provide long travel and have relatively high stiffness and load capacity. They are more resistant to shock than other types of bearings and fairly immune to contamination, but their friction varies with translation speed. This makes precise control difficult and limits the resolution of the stage.

Ball bearing slides reduce friction by replacing sliding motion with rolling motion. Balls are captured in guide ways by means of hardened steel rods as shown in Figure 8. The guide ways are externally loaded against the balls to eliminate unwanted runout in the bearings. Even with this preload, the friction is very low which results in extremely smooth travel with the capability to make small controlled incremental movements. Ball bearing slides are relatively insensitive to contamination because each ball contacts the guide ways at only a single point allowing dirt to be pushed out of the way instead of trapped. However, their point contact nature makes the balls and guide ways more susceptible to damage from overload, shock, or wear. Increased loading is possible using a double row of balls along machined bearing ways.

Crossed roller bearings offer all of the advantages of ball bearings with higher load capacity and higher stiffness. This is a consequence of replacing the point contact of a ball with the line contact of a roller. Bearings of this type require more care during assembly which results in higher costs. Reserve crossed roller slides for applications such as optical fiber coupling which require the greatest stability, stiffness, and robustness.

Flexures use elastic deformation to control motion as seen in Figure 8. The primary advantages of using a flexure suspension instead of bearings are higher stiffness, higher load capacity, and zero friction. Because there is no sliding or rolling contact between the moving parts of the stage, friction is completely eliminated. The disadvantages of flexures are small range of travel, susceptibility to vibration, and a small amount of cross coupling between axes. Since flexures approximate straight line motion with a circular path there exists a second order cross coupling effect in the mechanism. Additionally, an improperly designed flexure mount can have an undesired resonant vibration frequency response.

**Series B90 (largest)**



**Series A15 (smallest)**





### Key features

- Travel range up to 102 mm (4")
- Maximum speed 10 mm/sec
- Linear recirculating ball system
- Special tempered aluminum
- Load up to 3 kg
- Limit switches integrated
- Module combination

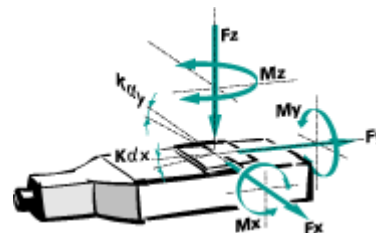

### FACTS

Load Characteristics	Fx (N)	Fy (N)	Fz (N)	Mx (N)	My (Nm)	Mz (Nm)	kax (μrad/Nm)	kay (μrad/Nm)
<a href="#">DC-B-024</a>	50	15	30	7.5	7.5	7.5	140	80
<a href="#">2Phase-045</a>	50	25	30	7.5	7.5	7.5	140	80

Special characteristic of the **NEW Linear Stage LS-65** linear stage is its compact structural shape. Typical applications for this measuring stage are inspection and micro-mounting systems for laser diodes and other highly sensitive components. A motionless precision ground leadscrew with 1mm pitch (option 0.4 mm pitch) guarantees a quiet, smooth move. The LS-65 linear stages are standardly equipped with a recirculating ball guiding system. LS-65 linear stages are alternatively equipped with a DC- or 2-phase-micro-step motor (SMC-technology). The LS-65 linear stages are standardly equipped with two optical or mechanical limit switches.

Tec  
hnical data

<b>Travel Range (mm)</b>	<b>26</b>	<b>52</b>	<b>77</b>	<b>102</b>
--------------------------	-----------	-----------	-----------	------------

Bi-directional Repeatability ( $\mu\text{m}$ )	+/- 5			
Accuracy ( $\mu\text{m}$ )	10			
Velocity Range (mm/sec)	0.001 ... 10			
Straightness / Flatness ( $\mu\text{m}$ )	+/- 4	< +/- 5	< +/- 6	< +/- 7
Pitch ( $\mu\text{rad}$ )	+/- 50	< +/- 60	< +/- 70	< +/- 80
Yaw ( $\mu\text{rad}$ )	+/- 60			
Ballscrew Pitch (mm)	1   0.4			

Speed max. (mm/sec)				
<a href="#">DC-B-024</a>	8   4			
<a href="#">2Phase-045</a>	10   4			

Resolution Open-Loop / 1 mm pitch ( $\mu\text{m}$ )				
<a href="#">2Phase-045</a>	0.1 (SMC)   5 (FS)			

Resolution Closed-Loop / 1 mm pitch ( $\mu\text{m}$ )				
<a href="#">RE-010</a> , Rotary encoder	0.5	higher resolution on request!		

**Note:** (SMC): Micro-Step Mode, (FS): Full-Step 2Phase

**More info:** Detailed information, concerning the motor and connectors, see: Appendix



# Linear encoders

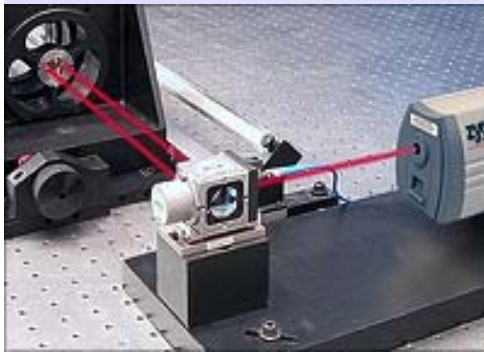
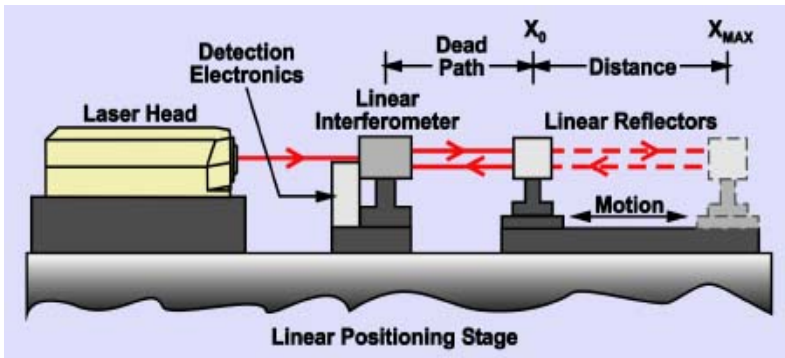

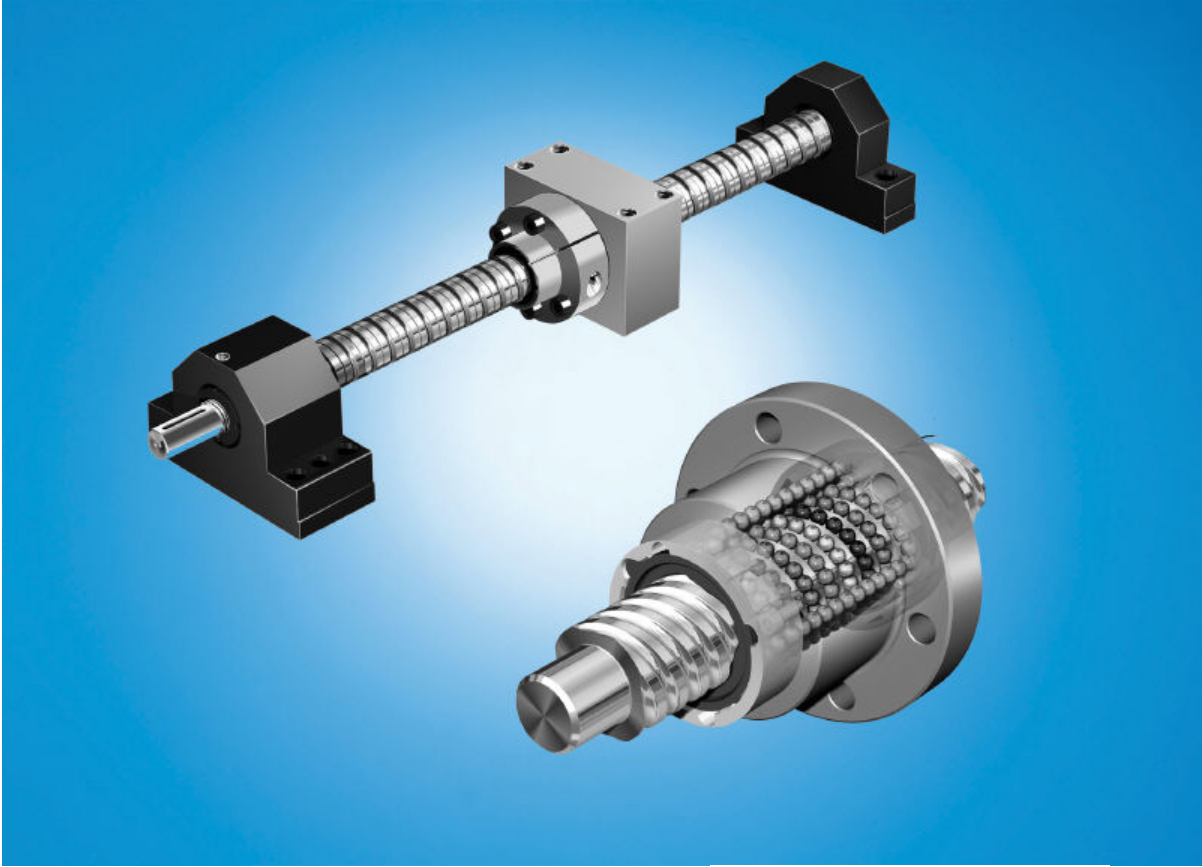

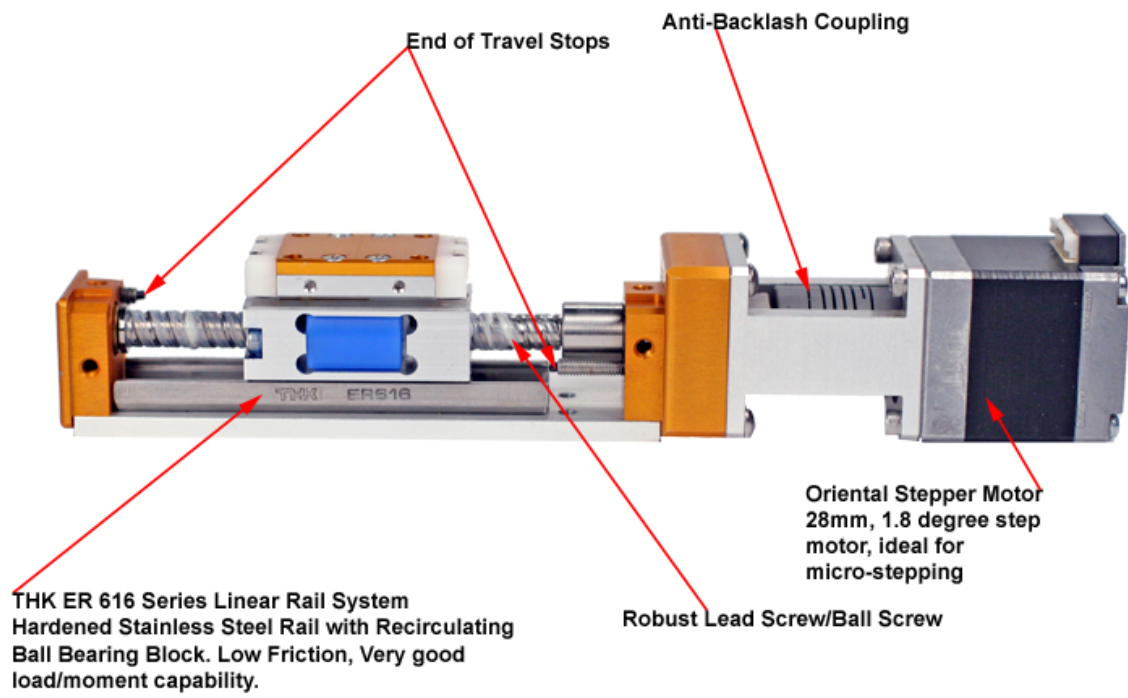

## Linear stages



Basic Model		ABL1000			
Total Travel		25 mm (1 in)	50 mm (2 in)	100 mm (4 in)	150 mm (6 in)
Drive System		Linear Brushless Servomotor			
Feedback		Noncontact Linear Encoder (LN or LT)			
Resolution	LN	1 nm (0.04 μin)			
	LT	5 nm (0.2 μin)			
Maximum Travel Speed <sup>(1)</sup>		300 mm/s (12 in/s)			
Maximum Load <sup>(2)</sup>		15.0 kg (33.0 lb)			
Overall Accuracy	LN <sup>(1)</sup>	±0.2 μm (±8 μin) <sup>(3)</sup> ; ±1 μm (±40 μin)	±0.2 μm (±8 μin) <sup>(3)</sup> ; ±1 μm (±40 μin)	±0.2 μm (±8 μin) <sup>(3)</sup> ; ±2 μm (±80 μin)	±0.5 μm (±20 μin) <sup>(3)</sup> ; ±5 μm (±200 μin)
	LT <sup>(2)</sup>	±0.3 μm (±12 μin) <sup>(3)</sup> ; ±2 μm (±80 μin)	±0.3 μm (±12 μin) <sup>(3)</sup> ; ±2 μm (±80 μin)	±0.3 μm (±12 μin) <sup>(3)</sup> ; ±5 μm (±200 μin)	±0.5 μm (±20 μin) <sup>(3)</sup> ; ±5 μm (±200 μin)
Repeatability	LN <sup>(3)</sup>	±50 nm (±2 μin)			
	LT <sup>(3)</sup>	±50 nm (±2 μin) <sup>(3)</sup> ; ±100 nm (±4 μin)			
Straightness and Flatness <sup>(4)</sup>	Differential	0.25 μm/25 mm (10 μin/in)			
	Max Deviation	±0.25 μm (±10 μin)	±0.25 μm (±10 μin)	±0.4 μm (±16 μin)	±0.4 μm (±16 μin)
Pitch/Roll/Yaw		±0.25 arc sec/25 mm	±0.25 arc sec/25 mm	±0.25 arc sec/25 mm	±1.5 arc sec/25 mm
Operating Pressure <sup>(5)</sup>		80 psi ±5 psi			
Air Consumption <sup>(6)</sup>		<0.3 cfm @ 80 psi			
Stage Weight		4.5 kg (10 lb)	5.5 kg (12 lb)	6.4 kg (14 lb)	12.7 kg (28 lb)
Carriage Weight		2.3 kg (5 lb)			4.5 kg (10 lb)

**Notes:**

1. Maximum speed based on stage capability; maximum application velocity may be limited by system data rate and system resolution.
2. Max load for XY configuration is 10.0 kg
3. Values with Aerotech controls and HAL option.
4. Dependent on flatness of stage mounting surface.
5. To protect air bearing against under-pressure, an in-line pressure switch is required and tied to the controller E-stop input.
6. Air supply must be clean, dry to 0° F dew point, and filtered to 0.25 μm or better; recommend nitrogen at 99.99% purity.

# Air bearing components

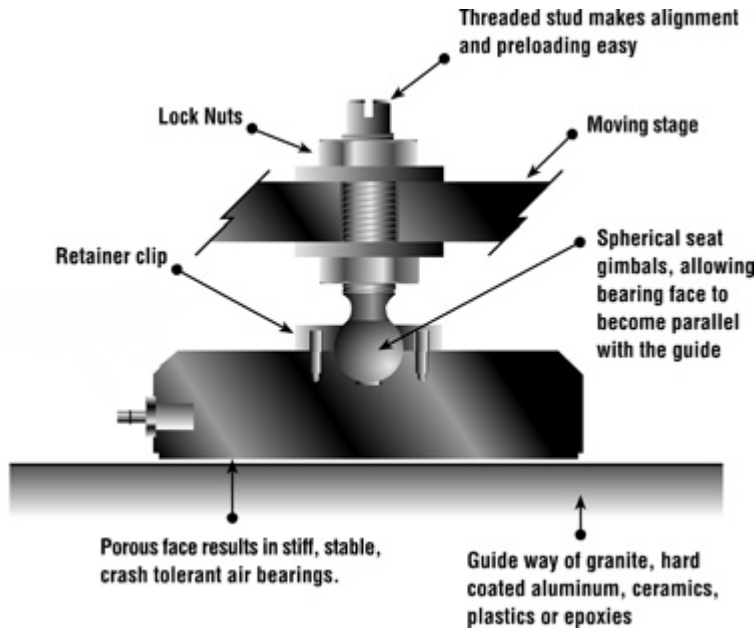

	<u>FLAT AIR BEARING</u>	<u>AIR BUSHINGS</u>	<u>VACUUM PRELOADED</u>	<u>AIR SLIDES</u>
				
<b>COST</b> <a href="#">top</a>	This is the most common type of air bearing in use in a stage. Pads are inexpensive. Stage structures can be made inexpensively. Guide ways are the more expensive component. The number of bearings can add up in a large or complicated application.	This is the least expensive air bearing system. Round shafting is readily available. Only 3 bushings are required to constrain a stage to a single axis of motion.	Using vacuum preloaded air bearings (VPLs) on a single plane can provide X and Y motion, saving costs. However, VPLs are more expensive than flat pads as they are more complex and larger. VPLs are flexure-mounted which can also add to costs. VPLs may be bonded into place with a patented process to reduce mounting costs.	Air slides have air bearings integrated into them and fit to a guide way. This minimizes assembly, inventory, and purchase part lists for the customer, but will most often be the most expensive.
<b>ASSEMBLY</b>	Easiest assembly. Low cost mounting	Easy assembly. "O" rings provide self-alignment.	VPL systems require more assembly care. Most flexure	No customer assembly required.

<a href="#">top</a>	components. Flexibility in alignments from fine pitch threaded studs that allow precise adjustment.	Mounting components are easy sourced by the customer or can be purchased from New Way.	designs are somewhat fragile. Patented vacuum replication process can be employed (with license agreement) for robust and inexpensive mounting.	
<a href="#">PRECISION</a> <a href="#">top</a>	The straightness of motion will be dependent on the accuracy of the guide ways used. When preloaded by an opposing pad the stage will be overconstrained. In some cases, errors in the guide may be averaged.	Round way slides can achieve high accuracies especially when strokes are limited to less than 6". Most air bushing slides are employed where smoothness, speed, or low friction are required. Consider oversizing the bushing to improve precision.	Because VPLs can be arranged kinematically correct, the highest precision is possible. Of course, other precision engineering principals will also need to be adhered to in order to achieve this high precision.	Because air slides can often have more air bearing surface area and shorter distances between pay load and guide, they will have higher stiffness and less angular errors caused by off drive axis masses.
<a href="#">STIFFNESS</a> <a href="#">top</a>	Preloaded flat pads have high stiffness. In most cases bending or diaphragm effects of the structure result in lower structure stiffness than in air films.	Since bushings guide on end supported shafts, bending of the shaft is usually the limiting factor in system stiffness. The "O" ring mounting can also limit stiffness. A simple potting procedure can hard fix this compliance. Stiff bushing slides can be constructed with short strokes. See bushing section for more detail on how gaps affect performance.	VPLs have variable stiffness. System stiffness is often limited by the mounting flexure. Our standard VPLs are best used in lightly loaded, low acceleration, ultra high precision applications where their exact constraint is used to advantage. More robust systems with higher load capacities and stiffness can be constructed using large custom VPLs and our replication process.	New Way air slides built with our patented replication process offer the highest stiffness for a given space.
<a href="#">LOAD CAPACITY</a> <a href="#">top</a>	Flat bearings have the highest load capacity. Standard bearings can carry over 2000 lbs each, and custom over 10,000 lbs each.	Air bushings have limited load capacity. The "O" ring mount makes it possible to gang them together to increase load capacity.	Flexure mounted modular VPLs have very limited load capacity. Larger, bonded VPLs can have much higher load capacities.	Air slides can have high load capacity.
<a href="#">PLUMBING</a> <a href="#">top</a>	Plumbing is simple. One air line goes to a manifold on each axis, with bearings from that axis fed from the manifold.	As air bushing slides can be made with fewer bearings, plumbing often is simpler.	Second supply tube required for vacuum. Vacuum supply tube should be as large a diameter as possible for good conductance.	Air slides are the simplest to plumb. They require only one air pressure line.

[www.newwayairbearings.com](http://www.newwayairbearings.com)

## Piezo transducers

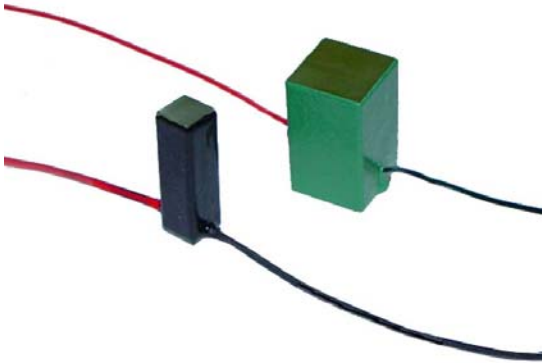

# Rotary stages, Mechanical bearings



## Rotary air bearings



ADR160 Series		ADR160-12	ADR160-21
Motor		S-130-39	S-130-60
Table Diameter		160 mm (6.3 in)	
Aperture		50 mm	
Total Travel		±360° Continuous	
Drive System		Direct-Drive Brushless Servomotor	
Feedback		23,600 line count/revolution	
Resolution		0.13-13.1 μrad (0.027-2.7 arc sec)	
Accuracy <sup>(1)</sup>		±24.3 μrad (±5 arc sec)	
Repeatability		±4.9 μrad (±1 arc sec)	
Maximum Rotary Speed		800 rpm	
Maximum Load	Axial	25 kg (55 lb)	
	Radial	10 kg (22 lb)	
Torque Output	Peak	11.7 N-m	21.2 N-m
	Continuous	2.8 N-m	5.2 N-m
Axis Wobble		14.6 μrad (3 arc sec)	
Axis Runout	Axial	2.0 μm (80 μin)	
	Radial	2.0 μm (80 μin)	
Nominal Stage Weight		9.5 kg (21 lb)	10.8 kg (23.8 lb)
Material	Shaft	Steel	
	Body	Aluminum	
Finish	Stage	Black Anodize	
	Table	Hardcoat	

Notes: 1. Value with Aerotech controls and HAL option

## Manually driven goniometers and tilt stages

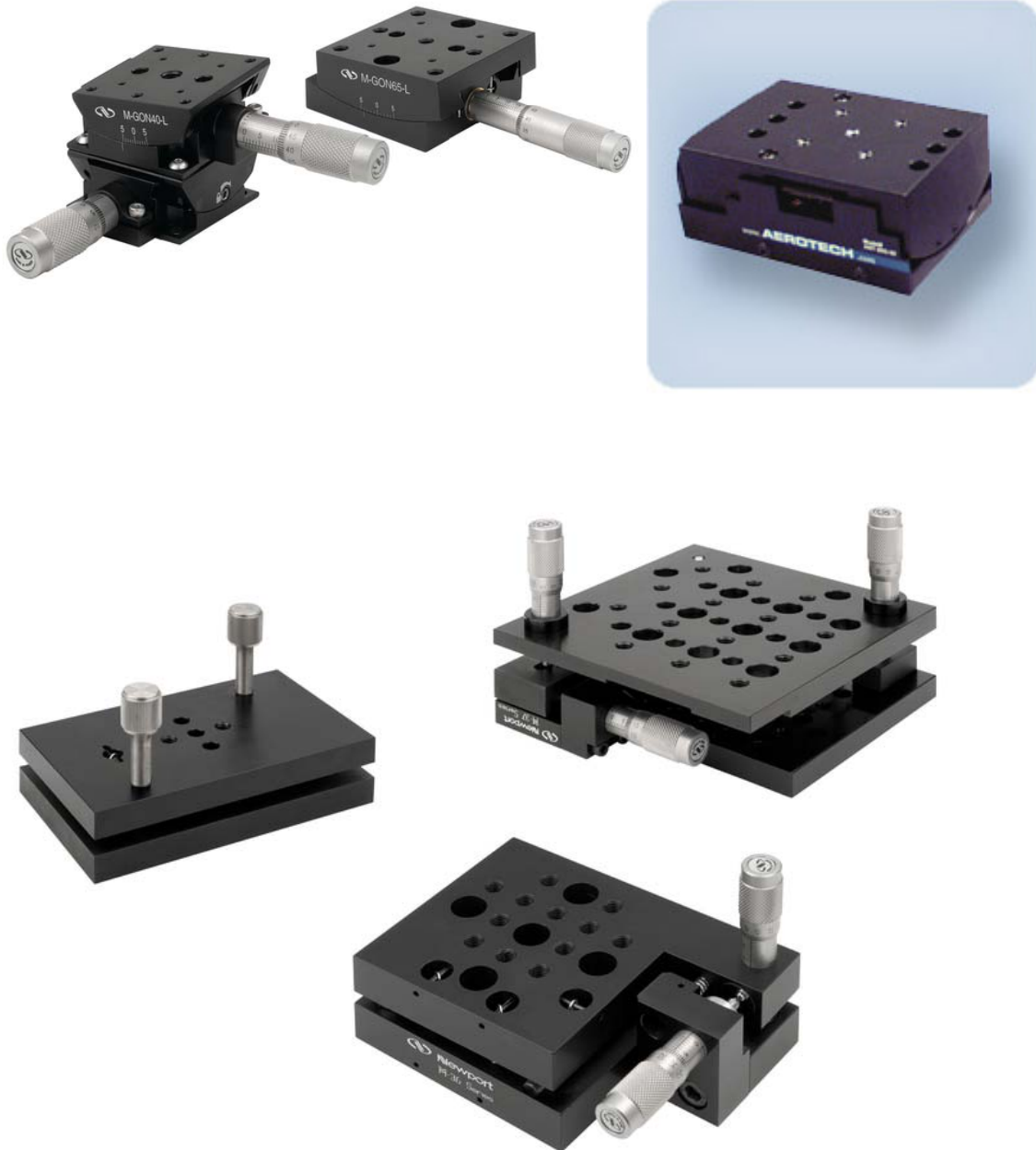

## Hexapod positioners

Stacked stages

Control is easy : x,y,z,... decoupled

Errors, slop, and compliance accumulate

Hexapod – Stewart platform

Actuators in parallel – increase stiffness

Provides 6 DoF, requires software control

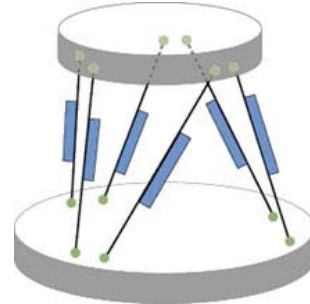
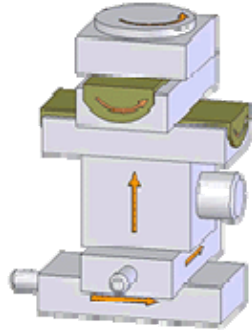

6 degrees of freedom constrained.

Each of 6 legs must be free to pivot and rotate at each end or it will bind.

By adjusting length of all 6 legs, you can move platform in 6 degrees of freedom.

(PI)

Need control matrix  $\mathbf{M}$

$$[\mathbf{M}] \cdot \begin{bmatrix} \Delta l_1 \\ \Delta l_2 \\ \Delta l_3 \\ \Delta l_4 \\ \Delta l_5 \\ \Delta l_6 \end{bmatrix} = \begin{bmatrix} \Delta x \\ \Delta y \\ \Delta z \\ \Delta \theta_x \\ \Delta \theta_y \\ \Delta \theta_z \end{bmatrix}$$

Get  $\mathbf{M}$  from measuring influence functions

1. Change  $l_1$  a small known amount  $\Delta l_1$

2. Measure change in all 6 degrees of freedom, write as column vector

$$\begin{bmatrix} \Delta x_1 \\ \Delta y_1 \\ \Delta z_1 \\ \Delta \theta_{x_1} \\ \Delta \theta_{y_1} \\ \Delta \theta_{z_1} \end{bmatrix}$$

3. This is the first column in the matrix  $\mathbf{M}$ . Repeat for the other 5 actuators to fill out the system matrix.

To control the position, multiply your desired change by the inverse of  $\mathbf{M}$ . This gives you the change in all 6 actuators.

$$[\mathbf{M}]^{-1} \cdot \begin{bmatrix} \Delta x \\ \Delta y \\ \Delta z \\ \Delta \theta_x \\ \Delta \theta_y \\ \Delta \theta_z \end{bmatrix} = \begin{bmatrix} \Delta l_1 \\ \Delta l_2 \\ \Delta l_3 \\ \Delta l_4 \\ \Delta l_5 \\ \Delta l_6 \end{bmatrix}$$

You can buy the controller from PI that does this for you.

- The key here is to be systematic.
- Any measurement errors or noise for determining the influence functions will propagate into your controls. You can improve the SNR by making larger adjustments for your influences. You can also improve this by making several measurements (move + and -).
- If you go far, the geometry may change enough for the matrix to change.