

October 21, 2008 Lecture 17

Name _____

Closed book; closed notes. Time limit: 75 minutes.

An equation sheets is included. A spare raytrace sheet is also attached

Use the back sides if required.

Do not use any pre-stored information or programs in your calculator.

Assume thin lenses in air if not specified.

If a method of solution is specified in the problem, that method must be used.

You must show your work and/or method of solution in order to receive credit or partial credit for your answer.

Distance Students: Please return the original exam only; do not FAX or scan an additional copy.

1) (10 points) Draw the tunnel diagram for beam displacement deviation prism with the ray path shown. The tunnel diagram must be drawn to the same scale as the prism drawing. It may be helpful to first describe the given prism system in terms of component prisms.

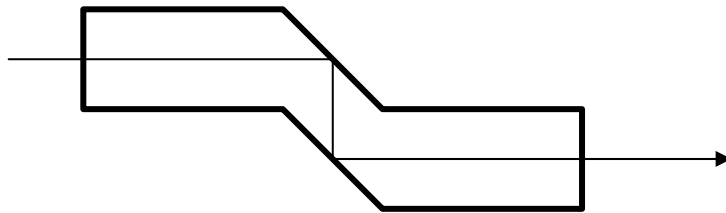

2) (10 points) What is the angular field of view of an optical system consisting of a 38 mm focal length lens with a 2 cm diameter detector? The object is at infinity. Provide the full field of view, and the system is in air.

Field of View = _____ deg

3) (10 points) My favorite building on the campus is the West Wing of the Meinel Building that houses the College of Optical Sciences. The building rises to a height of about 80 feet. You are standing across the mall and taking a picture of this building with a digital camera that has a 1 cm square detector. The mall is about 200 feet wide, and the image of the building should fill the vertical dimension of the sensor. Approximately what focal length lens is required?

$f \approx$ _____ mm

4) An air-spaced triplet is comprised of three thin lenses in air:

$$\begin{array}{ll} f_1 = 20 \text{ mm} & t_1 = 10 \text{ mm} \\ f_2 = -20 \text{ mm} & t_2 = 5 \text{ mm} \\ f_3 = 20 \text{ mm} & \end{array}$$

Note: No raytrace analysis is permitted for either portion of this problem.

a) (15 points) Use Gaussian methods to determine the system Focal Length and Back Focal Distance.

Continues...

$$f = \underline{\hspace{2cm}} \text{ mm}$$

$$\text{BFD} = \underline{\hspace{2cm}} \text{ mm}$$

b) (15 points) The system stop has a diameter of 10 mm and is located halfway between the first two thin lenses (5 mm behind the first lens). Use Gaussian methods to determine the locations and sizes of the system Entrance and Exit Pupils.

EP: $D_{EP} =$ _____ mm; Located _____ mm to the _____ of the first lens.

XP: $D_{XP} =$ _____ mm; Located _____ mm to the _____ of the third lens.

5) An optical system consists of two thick lenses in air with a stop between the lenses as shown. The diameter of the stop is 20 mm.

All of the radii of curvature are 100 mm. Use the diagram to determine the sign for each surface radius of curvature.

The index of the first lens is 1.5, and the index of the second lens is 1.7

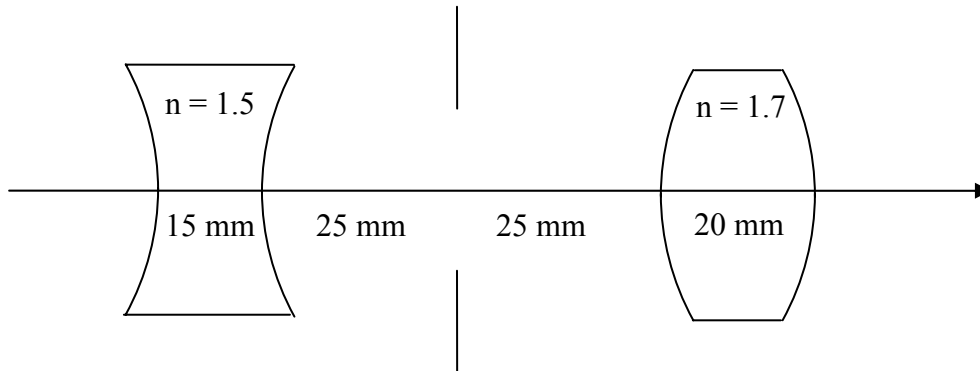

This problem is to be worked using raytrace methods only. Gaussian imaging methods may not be used for any portion of this problem.

For grading purposes, the values for your final rays must be entered into the raytrace sheets that follow. Use the raytrace sheets noted for the marginal ray and the chief ray.

Be sure to clearly label your rays, and note which ray is used to determine each answer.

a) (10 points) Determine the locations of the entrance and exit pupils.

Entrance Pupil: _____ mm to the _____ of the first surface.

Exit Pupil: _____ mm to the _____ of the last surface.

b) (10 points) Determine the focal length and back focal distance of this optical system.

$$f = \underline{\hspace{2cm}} \text{ mm} \qquad \text{BFD} = \underline{\hspace{2cm}} \text{ mm}$$

c) (10 points) Determine the diameters of the Entrance and Exit Pupils.

$$\text{Entrance Pupil Diameter} = \underline{\hspace{2cm}} \text{ mm}$$

$$\text{Exit Pupil Diameter} = \underline{\hspace{2cm}} \text{ mm}$$

d) (10 points) The system has a Field of View of +/- 10 degrees. What is the image height corresponding to this FOV?

Image Height = +/- _____ mm

OPTI-502 Equation Sheet Midterm

$$\text{OPL} = nl$$

$$n_1 \sin \theta_1 = n_2 \sin \theta_2$$

$$\gamma = 2\alpha$$

$$d = t \left(\frac{n-1}{n} \right) = t - \tau$$

$$\phi = (n' - n)C$$

$$\frac{n'}{z'} = \frac{n}{z} + \phi$$

$$f_E = \frac{1}{\phi} = -\frac{f_F}{n} = \frac{f'_R}{n'}$$

$$m = \frac{z'/n'}{z/n} = \frac{\omega}{\omega'}$$

$$m = \frac{f_{F2}}{f'_{R1}} = -\frac{f_2}{f_1}$$

$$\bar{m} = \frac{n'}{n} m^2$$

$$\frac{\Delta z'/n'}{\Delta z/n} = m_1 m_2$$

$$m_N = \frac{n}{n'}$$

$$P'N' = PN = f_F + f'_R$$

$$\tau = \frac{t}{n} \quad \omega = nu$$

$$\phi = \phi_1 + \phi_2 - \phi_1 \phi_2 \tau$$

$$\delta' = \frac{d'}{n'} = -\frac{\phi_1}{\phi} \tau \quad \text{BFD} = d' + f'_R$$

$$\delta = \frac{d}{n} = \frac{\phi_2}{\phi} \tau \quad \text{FFD} = d + f_F$$

$$\omega' = \omega - y\phi$$

$$y' = y + \omega' \tau'$$

$$f/\# \equiv \frac{f_E}{D_{EP}} \quad \text{NA} \equiv n |\sin U| \approx n |u|$$

$$f/\#_w \equiv \frac{1}{2\text{NA}} \approx \frac{1}{2n|u|} \approx (1-m) f/\#$$

$$I = H = n\bar{u}y - nu\bar{y}$$

$$\bar{u} = \tan(\theta_{1/2})$$