

WRITTEN PRELIM EXAM – FIRST DAY

Spring 2010

March 9, 2010

8:30 a.m. to 12:00 p.m.

Answer all six questions. Start each answer on a new page.

In the upper right hand corner of each sheet you hand in, put your code number (NO NAMES PLEASE) and the problem number. Staple together all sheets for a given problem.

Insert your answers into the manila envelope supplied and note which problems you have answered on the outside of the envelope.

The following are some helpful items:

$h = 6.625 \times 10^{-34} \text{ J} \cdot \text{s} = 4.134 \times 10^{-15} \text{ eV} \cdot \text{s}$	$\nabla(\phi + \psi) = \nabla\phi + \nabla\psi$
$e = 1.6 \times 10^{-19} \text{ C}$	$\nabla\phi\psi = \phi\nabla\psi + \psi\nabla\phi$
$c = 3.0 \times 10^8 \text{ m/s}$	$\nabla \cdot (\mathbf{F} + \mathbf{G}) = \nabla \cdot \mathbf{F} + \nabla \cdot \mathbf{G}$
$k_B = 1.38 \times 10^{-23} \text{ J/K}$	$\nabla \times (\mathbf{F} + \mathbf{G}) = \nabla \times \mathbf{F} + \nabla \times \mathbf{G}$
$\sigma = 5.67 \times 10^{-8} \text{ W/K}^4 \cdot \text{m}^2$	$\nabla(\mathbf{F} \cdot \mathbf{G}) = (\mathbf{F} \cdot \nabla)\mathbf{G} + (\mathbf{G} \cdot \nabla)\mathbf{F} + \mathbf{F} \times (\nabla \times \mathbf{G}) + \mathbf{G} \times (\nabla \times \mathbf{F})$
$\epsilon_0 = 8.85 \times 10^{-12} \text{ F/m}$	$\nabla \cdot (\phi\mathbf{F}) = \phi(\nabla \cdot \mathbf{F}) + \mathbf{F} \cdot \nabla\phi$
$\mu_0 = 1.26 \times 10^{-6} \text{ H/m}$	$\nabla \cdot (\mathbf{F} \times \mathbf{G}) = \mathbf{G} \cdot \nabla \times \mathbf{F} - \mathbf{F} \cdot \nabla \times \mathbf{G}$
$\sin(A \pm B) = \sin A \cos B \pm \cos A \sin B$	$\nabla \cdot (\nabla \times \mathbf{F}) = 0$
$\cos(A \pm B) = \cos A \cos B \mp \sin A \sin B$	$\nabla \times (\phi\mathbf{F}) = \phi(\nabla \times \mathbf{F}) + \nabla\phi \times \mathbf{F}$
$2 \cos A \cos B = \cos(A - B) + \cos(A + B)$	$\nabla \times (\mathbf{F} \times \mathbf{G}) = \mathbf{F}(\nabla \cdot \mathbf{G}) - \mathbf{G}(\nabla \cdot \mathbf{F}) + (\mathbf{G} \cdot \nabla)\mathbf{F} - (\mathbf{F} \cdot \nabla)\mathbf{G}$
$2 \sin A \sin B = \cos(A - B) - \cos(A + B)$	$\nabla \times (\nabla \times \mathbf{F}) = \nabla(\nabla \cdot \mathbf{F}) - \nabla^2\mathbf{F}$
$2 \sin A \cos B = \sin(A + B) + \sin(A - B)$	$\nabla \times \nabla\phi = 0$
$2 \cos A \sin B = \sin(A + B) - \sin(A - B)$	$\oint_S (\mathbf{F} \cdot \mathbf{n}) da = \int_V (\nabla \cdot \mathbf{F}) d^3x$
$\sin 2A = 2 \sin A \cos A$	$\oint_C \mathbf{F} \cdot d\ell = \int_S (\nabla \times \mathbf{F}) \cdot \mathbf{n} da$
$\cos 2A = 2 \cos^2 A - 1$	$\oint_S \phi \mathbf{n} da = \int_V \nabla\phi d^3x$
$\cos 2A = 1 - 2 \sin^2 A$	$\oint_S \mathbf{F}(\mathbf{G} \cdot \mathbf{n}) da = \int_V [\mathbf{F}(\nabla \cdot \mathbf{G}) + (\mathbf{G} \cdot \nabla)\mathbf{F}] d^3x$
$\sinh x = \frac{1}{2} (e^x - e^{-x})$	$\oint_S (\mathbf{n} \times \mathbf{F}) da = \int_V (\nabla \times \mathbf{F}) d^3x$
$\cosh x = \frac{1}{2} (e^x + e^{-x})$	

At the boundary between a transparent dielectric medium of refractive index $n_1 = \sqrt{\epsilon_1}$ and a second medium of *complex* refractive index $n_2 + i\kappa_2 = \sqrt{\epsilon_2} = \sqrt{\epsilon_2' + i\epsilon_2''}$, the Fresnel reflection coefficients for *p*- and *s*-polarized plane-waves arriving at an incidence angle θ are given by:

$$\rho_p = E_{x0}^r / E_{x0}^i = \frac{n_1 \sqrt{\epsilon_2 - n_1^2 \sin^2 \theta} - \epsilon_2 \cos \theta}{n_1 \sqrt{\epsilon_2 - n_1^2 \sin^2 \theta} + \epsilon_2 \cos \theta},$$

$$\rho_s = E_{y0}^r / E_{y0}^i = \frac{n_1 \cos \theta - \sqrt{\epsilon_2 - n_1^2 \sin^2 \theta}}{n_1 \cos \theta + \sqrt{\epsilon_2 - n_1^2 \sin^2 \theta}}.$$

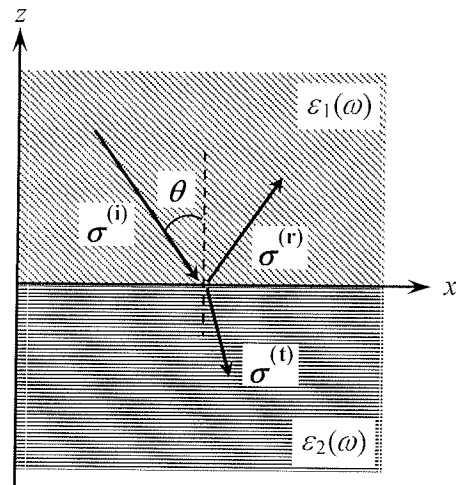

The relative permeabilities of both media are assumed to be unity, that is, $\mu_1 = \mu_2 = 1$. Note that the dielectric constant ϵ_1 of the incidence medium is real-valued and positive, whereas that of the second medium, ϵ_2 , is allowed to be complex-valued as well.

- 1 Pt a) What are the Fresnel reflection coefficients at normal incidence? If you found that $\rho_p = \rho_s$, explain why this result should be expected at normal incidence.
- 3 Pts b) Under what circumstances does one observe total internal reflection (TIR) in this problem? What is the critical incidence angle θ_c at which TIR begins? Do you expect the same critical angle for both *p*- and *s*-polarized plane-waves? Explain.
- 3 Pts c) Under what conditions does one arrive at Brewster's angle in this problem? Is there a Brewster's angle for *s*-polarized light? Why not?
- 1 Pt d) Can there be a Brewster's angle if the second medium is not transparent, that is, if $\kappa_2 \neq 0$?
- 1 Pt e) What are the limiting values of ρ_p and ρ_s as one approaches grazing incidence (i.e., when $\theta \rightarrow 90^\circ$)?
- 1 Pt f) Can there be total reflection (i.e., 100% reflectivity) at the interface if the second medium is not transparent, that is, if $\kappa_2 \neq 0$?
-

Explicit Forms of Vector Operations

Let $\mathbf{e}_1, \mathbf{e}_2, \mathbf{e}_3$ be orthogonal unit vectors associated with the coordinate directions specified in the headings on the left, and A_1, A_2, A_3 be the corresponding components of \mathbf{A} . Then

Cartesian ($x_1, x_2, x_3 = x, y, z$)	$\nabla\psi = \mathbf{e}_1 \frac{\partial\psi}{\partial x_1} + \mathbf{e}_2 \frac{\partial\psi}{\partial x_2} + \mathbf{e}_3 \frac{\partial\psi}{\partial x_3}$ $\nabla \cdot \mathbf{A} = \frac{\partial A_1}{\partial x_1} + \frac{\partial A_2}{\partial x_2} + \frac{\partial A_3}{\partial x_3}$ $\nabla \times \mathbf{A} = \mathbf{e}_1 \left(\frac{\partial A_3}{\partial x_2} - \frac{\partial A_2}{\partial x_3} \right) + \mathbf{e}_2 \left(\frac{\partial A_1}{\partial x_3} - \frac{\partial A_3}{\partial x_1} \right) + \mathbf{e}_3 \left(\frac{\partial A_2}{\partial x_1} - \frac{\partial A_1}{\partial x_2} \right)$ $\nabla^2\psi = \frac{\partial^2\psi}{\partial x_1^2} + \frac{\partial^2\psi}{\partial x_2^2} + \frac{\partial^2\psi}{\partial x_3^2}$
Cylindrical (ρ, ϕ, z)	$\nabla\psi = \mathbf{e}_1 \frac{\partial\psi}{\partial\rho} + \mathbf{e}_2 \frac{1}{\rho} \frac{\partial\psi}{\partial\phi} + \mathbf{e}_3 \frac{\partial\psi}{\partial z}$ $\nabla \cdot \mathbf{A} = \frac{1}{\rho} \frac{\partial}{\partial\rho} (\rho A_1) + \frac{1}{\rho} \frac{\partial A_2}{\partial\phi} + \frac{\partial A_3}{\partial z}$ $\nabla \times \mathbf{A} = \mathbf{e}_1 \left(\frac{1}{\rho} \frac{\partial A_3}{\partial\phi} - \frac{\partial A_2}{\partial z} \right) + \mathbf{e}_2 \left(\frac{\partial A_1}{\partial z} - \frac{\partial A_3}{\partial\rho} \right) + \mathbf{e}_3 \left(\frac{\partial}{\partial\rho} (\rho A_2) - \frac{\partial A_1}{\partial\phi} \right)$ $\nabla^2\psi = \frac{1}{\rho} \frac{\partial}{\partial\rho} \left(\rho \frac{\partial\psi}{\partial\rho} \right) + \frac{1}{\rho^2} \frac{\partial^2\psi}{\partial\phi^2} + \frac{\partial^2\psi}{\partial z^2}$
Spherical (r, θ, ϕ)	$\nabla\psi = \mathbf{e}_1 \frac{\partial\psi}{\partial r} + \mathbf{e}_2 \frac{1}{r} \frac{\partial\psi}{\partial\theta} + \mathbf{e}_3 \frac{1}{r \sin\theta} \frac{\partial\psi}{\partial\phi}$ $\nabla \cdot \mathbf{A} = \frac{1}{r^2} \frac{\partial}{\partial r} (r^2 A_1) + \frac{1}{r \sin\theta} \frac{\partial}{\partial\theta} (\sin\theta A_2) + \frac{1}{r \sin\theta} \frac{\partial A_3}{\partial\phi}$ $\nabla \times \mathbf{A} = \mathbf{e}_1 \frac{1}{r \sin\theta} \left[\frac{\partial}{\partial\theta} (\sin\theta A_3) - \frac{\partial A_2}{\partial\phi} \right]$ $+ \mathbf{e}_2 \left[\frac{1}{r \sin\theta} \frac{\partial A_1}{\partial\phi} - \frac{1}{r} \frac{\partial}{\partial r} (r A_3) \right] + \mathbf{e}_3 \left[\frac{\partial}{\partial r} (r A_2) - \frac{\partial A_1}{\partial\theta} \right]$ $\nabla^2\psi = \frac{1}{r^2} \frac{\partial}{\partial r} \left(r^2 \frac{\partial\psi}{\partial r} \right) + \frac{1}{r^2 \sin\theta} \frac{\partial}{\partial\theta} \left(\sin\theta \frac{\partial\psi}{\partial\theta} \right) + \frac{1}{r^2 \sin^2\theta} \frac{\partial^2\psi}{\partial\phi^2}$ <p style="text-align: center;">[Note that $\frac{1}{r^2} \frac{\partial}{\partial r} \left(r^2 \frac{\partial\psi}{\partial r} \right) = \frac{1}{r} \frac{\partial^2}{\partial r^2} (r\psi)]$</p>

A thin, short wire of length d , placed at the origin of a spherical coordinate system, carries the sinusoidal current $I(t) = I_0 \sin(2\pi f t)$ along the z -axis. The scalar and vector potentials in the surrounding free-space are given by

$$\psi(r, t) = \frac{Z_0 I_0 d}{4\pi} \cos\theta \left\{ \frac{1}{r} \sin[2\pi f(t - \frac{r}{c})] - \left(\frac{\lambda_0}{2\pi r^2}\right) \cos[2\pi f(t - \frac{r}{c})] \right\},$$

$$\mathbf{A}(r, t) = \frac{\mu_0 I_0 d}{4\pi r} \sin[2\pi f(t - \frac{r}{c})] \hat{z}.$$

In the above equations, $c = 1/\sqrt{\mu_0 \epsilon_0}$ is the speed of light in vacuum, while $Z_0 = \sqrt{\mu_0/\epsilon_0}$ is the impedance of the free space. The vacuum wavelength $\lambda_0 = c/f$, and, in case you would like to work in spherical coordinates, $\hat{z} = \cos\theta \hat{r} - \sin\theta \hat{\theta}$.

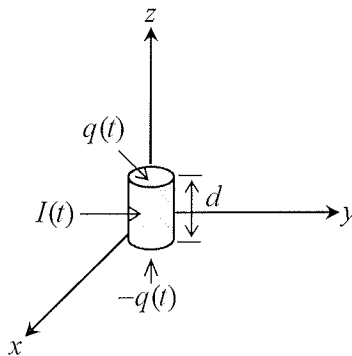

- 1 Pt a) Find the electric charge $\pm q(t)$ at the top and bottom of the oscillator.
- 1 Pt b) What is the strength of this electric dipole oscillator, $\mathbf{p}(t)$?
- 3 Pts c) Find the magnetic field distribution $\mathbf{H}(\mathbf{r}, t)$ in the entire space surrounding the oscillator.
- 3 Pts d) Find the electric field distribution $\mathbf{E}(\mathbf{r}, t)$ in the entire space surrounding the oscillator.
- 2 Pts e) Determine the Poynting vector $\mathbf{S}(\mathbf{r}, t)$ in the far-field region of the dipole oscillator.
-

A camera system consisting of an objective lens of 100 mm focal length ($f/10$) and a 2×2 mm CCD detector has been assembled into a barrel mechanical structure as shown in Fig. 1. This camera works at essentially a single wavelength of 0.000587 mm.

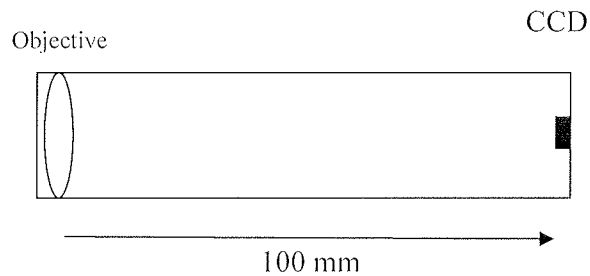

Figure 1

In each of the following three parts, additional optical elements or “correctors” must be added to the system to fix problems. All of these elements must be placed in front of the objective lens (to the left of the objective lens). The separation between the objective lens and the CCD cannot be changed.

Be sure to explain how the customer will use each of your specified “correctors.” Include a drawing showing the layout. Note that each of these problems are separate and the “correctors” are used one at a time.

- 1) Due to problems in manufacturing, it has been found that when the camera is properly pointed at an object, the image is displaced 0.2 mm off the center of the CCD. Provide an optical means (a single optical element and its specification) to correct the position of the image so that it falls at the center of the CCD. (3 points)
- 2) Carefully examination of the image reveals that it focuses 0.8 mm in front of the CCD. Provide an optical means (a single optical element and its specification) to correct this problem. (3 points)
- 3) It turns out that due to lack of communication, the field of view specification was wrong. Instead of covering a full field of view of 3.24 degrees it is required to cover a full field of view of 4.86 degrees (one and half times the original field). Provide an optical means (one or two optical elements and their specification) to increase the field of view image on the CCD. (4 points)

- a.) (2.5 pts) An ideal point source in air with $\lambda = 1\mu\text{m}$ is placed at the center of curvature of a spherical mirror, as shown below, where $R = 100\text{ mm}$ and $D = 50\text{ mm}$. Describe the interference pattern generated between the point-source wave and the wave reflected by the mirror in a region between the source and the mirror. Include in your analysis fringe spacing and shape, if fringes are present. You may assume that the mirror is perfect and does not introduce any additional phase shift, and that scattering from edges of the mirror can be neglected.
- b.) (2.5 pts) Repeat your analysis for (a) for the region to the left-hand side of the source.
- c.) (2.5 pts) The source is moved axially a distance of $100\mu\text{m}$ toward the mirror vertex. Where is the location of the image of the source?
- d.) (2.5 pts) Assuming that the central fringe in the region to the left of the image point found in (c) is dark, what is the radius of the 5th dark fringe from the axis at a distance of 100 mm to the left of the center of curvature?

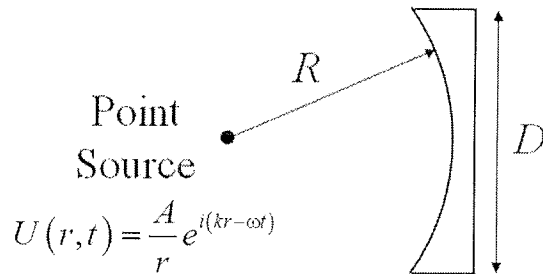

Consider a particle of mass m in a 1-dimensional time independent quantum harmonic potential of the form $V(x) = \frac{1}{2}m\omega^2x^2$. Suppose the wavefunction for the particle is given by:

$$\Psi(x, t) = A \cdot e^{-\frac{1}{2\sigma^2}\{x-a(t)\}^2} \cdot e^{ia_o\phi(x,t)} \cdot e^{-i\frac{\omega}{2}t}$$

where the normalization coefficient $A = (\frac{1}{\pi\sigma^2})^{1/4}$, $\sigma = \sqrt{\hbar/(m\omega)}$, and $a(t) = a_o\cos(\omega t)$ with a_o a real constant.

(a) Write down the Hamiltonian operator for this system. (1 point)

(b) For the case of $a_o = 0$, show that $\Psi(x, t)$ is a solution to the time-independent Schrodinger equation, and identify the energy eigenstate and its corresponding energy eigenvalue. (2 points)

For the remainder of this problem, assume $a_o \neq 0$.

(c) At time $t=0$, $\phi(x, 0) = 0$. (3 points)

(i) write down the wavefunction, $\Psi(x, 0)$.

(ii) Make a graph of $|\Psi(x, 0)|^2$ and label the expectation value of the particle's position, $\langle x \rangle$.

(iii) Calculate $\langle p \rangle$ by direct integration.

(*hint*: you do not need an integral table to solve this, but rather can use simple arguments, such as symmetry and the orthogonality relationship of energy eigenstates).

(d) At time $t = \frac{\pi}{2\omega}$, $\phi(x, t = \frac{\pi}{2\omega}) = -x/\sigma^2$. (3 points)

(i) write down the wavefunction, $\Psi(x, \frac{\pi}{2\omega})$.

(ii) Make a graph of $|\Psi(x, \frac{\pi}{2\omega})|^2$ and label the expectation value of the particle's position, $\langle x \rangle$.

(iii) Calculate $\langle p \rangle$.

(e) Is $\Psi(x, t)$ an energy eigenstate of the system? (1 point)

Spring 2010 Comprehensive Exam
Question 6

A laser cavity operating at a wavelength of $\lambda \approx 633$ nm consists of a flat mirror and a curved spherical mirror with respective radii of curvature $R_1 = \infty$ and $R_2 = 2 \cdot L$, where $L = 15$ cm is the cavity length. The only losses in the cavity come from the output coupler (flat mirror), with output coupling power transmission $T = 1\%$. The intracavity gain is provided from a dilute gas of atoms that fills the entire region between the two mirrors. The small signal gain coefficient is given by $\gamma_o(\nu) = 0.05 \cdot e^{-(\nu - \nu_o)^2 / \delta\nu^2} [m^{-1}]$, where ν is the optical frequency, ν_o is the atomic transition frequency, and $\delta\nu$ characterizes the gain linewidth. Assume $\delta\nu = 1$ GHz. The saturation intensity for the atomic transition is $I_{sat} = 10$ W/cm². (Additional useful expressions are listed below.)

- (a) Is this a stable cavity configuration? (1 point)
- (b) Write down expressions for the Gaussian beam wavefront radius of curvature, $R(z)$, and spot size, $w(z)$, as functions of propagation distance, z . Write your expressions in terms of the Rayleigh range parameter z_o . (1 point)
- (c) Determine the location of the beam waist in the cavity, and calculate its value, w_o , using the appropriate Gaussian beam expression from part (b). (2 points)
- (d) Calculate the maximum number of longitudinal modes that can simultaneously lase. (3 points)
- (e) Assume the laser is operating on a single longitudinal mode, whose frequency is detuned from the center of the atomic transition by $\nu - \nu_o = 0.1$ GHz. Calculate the on-axis intracavity intensity. (3 points)

$$z_o = \frac{\pi w_o^2}{\lambda}$$

$$\beta \approx \frac{T}{2L} \text{ (round trip loss coefficient)}$$

$$\gamma_{ss} = \frac{\gamma_o}{1 + \frac{I}{I_{sat}}} \text{ (saturated steady-state gain coefficient; } I = \text{ on-axis intracavity intensity)}$$

WRITTEN PRELIM EXAM – SECOND DAY

Spring 2010

March 10, 2010
8:30 a.m. to 12:00 p.m.

Answer all six questions. Start each answer on a new page.

In the upper right hand corner of each sheet you hand in, put your code number (NO NAMES PLEASE) and the problem number. Staple together all sheets for a given problem.

Insert your answers into the manila envelope supplied and note which problems you have answered on the outside of the envelope.

The following are some helpful items:

$h = 6.625 \times 10^{-34} \text{ J} \cdot \text{s} = 4.134 \times 10^{-15} \text{ eV} \cdot \text{s}$	$\nabla(\phi + \psi) = \nabla\phi + \nabla\psi$
$e = 1.6 \times 10^{-19} \text{ C}$	$\nabla\phi\psi = \phi\nabla\psi + \psi\nabla\phi$
$c = 3.0 \times 10^8 \text{ m/s}$	$\nabla \cdot (\mathbf{F} + \mathbf{G}) = \nabla \cdot \mathbf{F} + \nabla \cdot \mathbf{G}$
$k_B = 1.38 \times 10^{-23} \text{ J/K}$	$\nabla \times (\mathbf{F} + \mathbf{G}) = \nabla \times \mathbf{F} + \nabla \times \mathbf{G}$
$\sigma = 5.67 \times 10^{-8} \text{ W/K}^4 \cdot \text{m}^2$	$\nabla(\mathbf{F} \cdot \mathbf{G}) = (\mathbf{F} \cdot \nabla)\mathbf{G} + (\mathbf{G} \cdot \nabla)\mathbf{F} + \mathbf{F} \times (\nabla \times \mathbf{G}) + \mathbf{G} \times (\nabla \times \mathbf{F})$
$\epsilon_0 = 8.85 \times 10^{-12} \text{ F/m}$	$\nabla \cdot (\phi\mathbf{F}) = \phi(\nabla \cdot \mathbf{F}) + \mathbf{F} \cdot \nabla\phi$
$\mu_0 = 1.26 \times 10^{-6} \text{ H/m}$	$\nabla \cdot (\mathbf{F} \times \mathbf{G}) = \mathbf{G} \cdot \nabla \times \mathbf{F} - \mathbf{F} \cdot \nabla \times \mathbf{G}$
$\sin(A \pm B) = \sin A \cos B \pm \cos A \sin B$	$\nabla \cdot (\nabla \times \mathbf{F}) = 0$
$\cos(A \pm B) = \cos A \cos B \mp \sin A \sin B$	$\nabla \times (\phi\mathbf{F}) = \phi(\nabla \times \mathbf{F}) + \nabla\phi \times \mathbf{F}$
$2 \cos A \cos B = \cos(A - B) + \cos(A + B)$	$\nabla \times (\mathbf{F} \times \mathbf{G}) = \mathbf{F}(\nabla \cdot \mathbf{G}) - \mathbf{G}(\nabla \cdot \mathbf{F}) + (\mathbf{G} \cdot \nabla)\mathbf{F} - (\mathbf{F} \cdot \nabla)\mathbf{G}$
$2 \sin A \sin B = \cos(A - B) - \cos(A + B)$	$\nabla \times (\nabla \times \mathbf{F}) = \nabla(\nabla \cdot \mathbf{F}) - \nabla^2\mathbf{F}$
$2 \sin A \cos B = \sin(A + B) + \sin(A - B)$	$\nabla \times \nabla\phi = 0$
$2 \cos A \sin B = \sin(A + B) - \sin(A - B)$	$\oint_S (\mathbf{F} \cdot \mathbf{n}) da = \int_V (\nabla \cdot \mathbf{F}) d^3x$
$\sin 2A = 2 \sin A \cos A$	$\oint_C \mathbf{F} \cdot d\ell = \int_S (\nabla \times \mathbf{F}) \cdot \mathbf{n} da$
$\cos 2A = 2 \cos^2 A - 1$	$\oint_S \phi \mathbf{n} da = \int_V \nabla\phi d^3x$
$\cos 2A = 1 - 2 \sin^2 A$	$\oint_S \mathbf{F}(\mathbf{G} \cdot \mathbf{n}) da = \int_V [\mathbf{F}(\nabla \cdot \mathbf{G}) + (\mathbf{G} \cdot \nabla)\mathbf{F}] d^3x$
$\sinh x = \frac{1}{2}(e^x - e^{-x})$	$\oint_S (\mathbf{n} \times \mathbf{F}) da = \int_V (\nabla \times \mathbf{F}) d^3x$
$\cosh x = \frac{1}{2}(e^x + e^{-x})$	

Spring 2010 Comprehensive Exam
Question 7

502-2

Design a relayed-Keplerian (erect image – also known as a terrestrial telescope) using three thin lenses in air.

The system specifications are

Magnifying Power = 8X

Stop at the Objective Lens

Entrance Pupil Diameter = 25 mm

Telescope Length (Objective Lens to Eye Lens) = 305 mm

Field of View = ± 1 degree (HFOV = 1 degree)

The System is Unvignetted over this Field of View

The focal lengths of the three available lenses are

25 mm

40 mm

100 mm

Determine the system layout including the required lens diameters.

a) (2.5 pts) The fringe pattern below was recorded as a function of OPD in wavelength units. In this case, $\lambda = 500$ nm. What is the coherence length of the source in terms of OPD in units of meters?

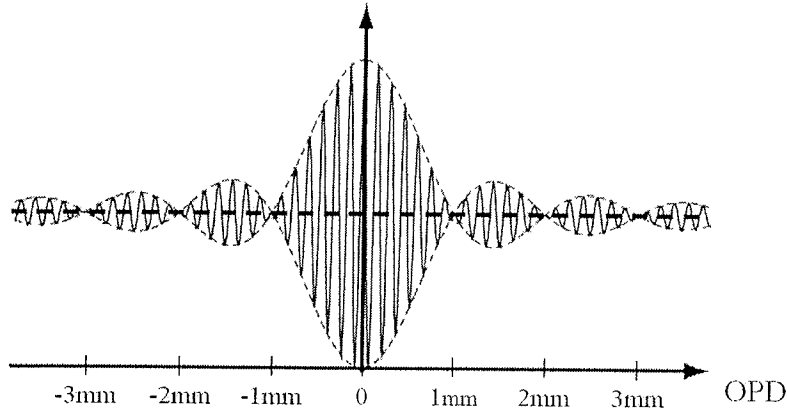

b) (2.5 pts) If the fringe pattern shown in (a) is measured on a Twyman-Green interferometer, how far does one of the mirrors need to move in order to change from maximum contrast fringes to the first minimum in visibility? State any assumptions you make.

c) (2.5 pts) The spectral distribution of a three-component light-emitting diode (LED) is shown below. If only the red (center wavelength = 635 nm) is used, what is the approximate coherence length in terms of distance that a Twyman-Green interferometer mirror needs to move? State any assumptions you make.

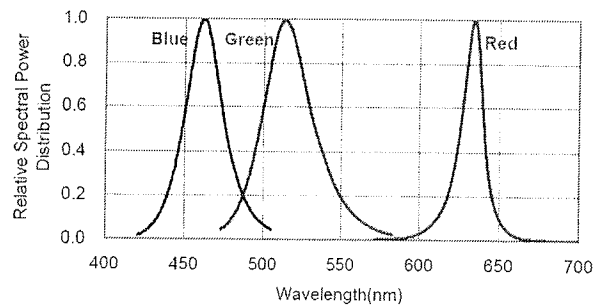

d.) (2.5 pts) Repeat (c) assuming that all three wavelengths are used.

1. Answer the following questions related to semiconductor detectors with macroscopic dimensions:
 - (a) Write the 3D time-independent Schrödinger equation for a single electron in a Bravais lattice defined by translation vector $\mathbf{R} = l\mathbf{a} + m\mathbf{b} + n\mathbf{c}$, where l, m , and n are integers. Show where periodicity is expressed in the Hamiltonian and explain what conditions are necessary to invoke the time-independent form of the Schrödinger equation to describe the electronic structure and related properties of crystals.
 - (b) What is the Born-von Karman boundary condition for a simple orthorhombic crystal ($|\mathbf{a}| \neq |\mathbf{b}| \neq |\mathbf{c}|, \alpha = \beta = \gamma = 90^\circ$) of size $L \times M \times N$ (\AA^3)? Why is it invoked?
 - (c) What is a Bloch function? Show that the application of Born-von Karman boundary condition (for example for the case above) leads to a discrete set of possible k (momentum) values for the electrons to occupy.
 - (d) What are energy bands and why do they arise? Sketch a one dimensional band diagram for the nearly-free electron model and compare it with the free electron curve (hint: x-axis units are momentum, y-axis units are energy). Point out the bandgaps.
 - (e) Explain why donor and acceptor impurities are added to Si. Sketch the location (in an *energy versus position* band diagram) of donor and acceptor dopant states relative to the conduction and valence bands.
 - (f) Draw the band structure of the PN junction, under conditions of a) no bias, b) forward bias and c) reverse bias. Which are useful for photodetection?

The following questions, all related to the Boltzmann transport equation, are equally weighted.

- (a) Define the phase-space distribution function, $w(\mathbf{r}, \hat{\mathbf{s}}, \mathcal{E}, t)$ and give the meaning of the four variables in its argument.
- (b) Give the SI units of $w(\mathbf{r}, \hat{\mathbf{s}}, \mathcal{E}, t)$.
- (c) How is $w(\mathbf{r}, \hat{\mathbf{s}}, \mathcal{E}, t)$ related to spectral photon radiance? Give the units of spectral photon radiance.
- (d) List the physical effects that contribute to the time derivative of the phase-space distribution function.
- (e) What is the general structure of the equation for the time derivative of the phase-space distribution function? You do not need to give the forms for the individual terms.
- (f) What conditions must be satisfied for $w(\mathbf{r}, \hat{\mathbf{s}}, \mathcal{E}, t)$ to reach a steady state, independent of t ?
- (g) What equation must be satisfied in steady state?

The band filling effect in semiconductors can be written as $\alpha(\epsilon, I) = \alpha(\epsilon, 0) \cdot A(\epsilon)$, where $A(\epsilon) = 1 - f_e(\epsilon) - f_h(\epsilon)$ is the band filling factor, $\alpha(\epsilon, I)$ is the absorption coefficient at a light intensity I , $\alpha(\epsilon, 0)$ is the linear absorption coefficient, $f_e(\epsilon)$ and $f_h(\epsilon)$ are the Fermi functions for electrons and holes, respectively.

- (a) 2 points. Derive the band filling factor (hint: use occupation probabilities of valance band and conduction band).
- (b) 2 points. Plot a typical linear absorption spectrum of a semiconductor near the band edge $\alpha(\epsilon, 0)$ when the light intensity is very low.
- (c) 2 points. Plot the absorption spectrum when the light intensity is increased $\alpha(\epsilon, I)$. Explain your answer.
- (d) 2 points. Is it possible for the absorption to become zero or negative if the light intensity continues to increase? Explain.
- (e) 2 points. Plot the absorption spectrum at such a high intensity as in part d.

Consider the phonons in a one-dimensional monatomic lattice with harmonic nearest neighbor interactions.

(a) Specify the general form of the solution $U_k(x_j, t)$ (in class it was simply denoted by U_j). Sketch the dispersion relation $\Omega(k)$, properly labeling all axes and special points.

(4 points)

(b) Show that you are allowed to restrict the dispersion relation to one Brillouin zone by proving that the solutions are periodic in k space with the periodicity of the reciprocal lattice vector G_m (where m is an integer).

(3 points)

(c) Assume you have a system of finite length $L = N \cdot a$, where a is the lattice constant and N the number of unit cells. Using periodic boundary conditions, $U_k(x_j + L, t) = U_k(x_j, t)$, show that the wave vector k is not a continuous variable anymore. Specifically, show that the total number of k -points, on which the dispersion relation is defined, is N .

(3 points)

OPTI 509: Topic – Aberrations of imaging systems

Field curves

The Petzval surface is defined as the curved focal surface where the focus of an imaging system will be maintained, in the absence of other aberrations. This surface has radius of curvature R_p , so the curvature is $1/R_p$.

1. (4) Determine the Petzval curvature for the following imaging systems, assuming object at infinity:

- a) 25 mm diameter biconvex lens with 500 mm focal length, $n = 1.5$, stop at the lens.
- b) Same as a), but shift the stop to a position 500 mm in front of the lens.
- c) Same as b), but bend the lens to plano-convex with flat side towards the stop.

- d) 25 mm diameter concave spherical mirror with 500 mm focal length, stop at the mirror
- e) Same as d), but shift the stop to a position 500 mm in front of the mirror

2. (2) For the case of d) above, the 500 mm focal length mirror with stop at the mirror, images of stars on a flat detector have the appearance shown below. The individual stars create line images that all point radially. (The magnitude shown below is **not** to scale.).

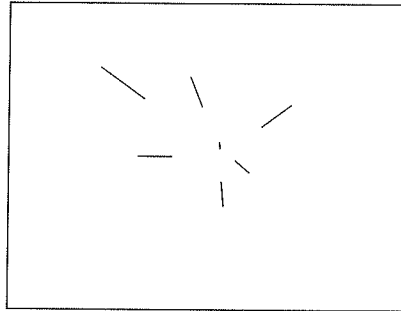

Sketch the following field curves for this system. Show the orientation of the curves with respect to the position of the mirror.

- P: Petzval curve
- S: Sagittal astigmatic focus
- M: Medial astigmatic focus
- T: Tangential astigmatic focus.

3. (4) For the mirror above:

- a) Evaluate the P, S, M, and T field curves at 50 mm off axis.
- b) Sketch the shape and size of an image of a star 50 mm off axis.
- c) How much focal shift is required to minimize the size of this image (medial focus)?
- d) Sketch the shape and show the size of this off-axis image at medial focus.

An earth-observing remote sensing imaging instrument has a lossless lambertian diffuser panel for on-orbit calibration. The accepted value for total solar irradiance at the spacecraft is 1367 W/m^2 . Assuming that the sun is $1.5 \times 10^8 \text{ km}$ from the earth, the angle between the diffuser panel normal and the sun is 45° , the angle between the diffuser panel normal and the instrument entrance aperture is 45° , the focal length of the instrument is 100 mm , and the instrument exit pupil diameter is 50 mm . Based on the geometry, calculate the following.

Each part of the problem is weighted equally.

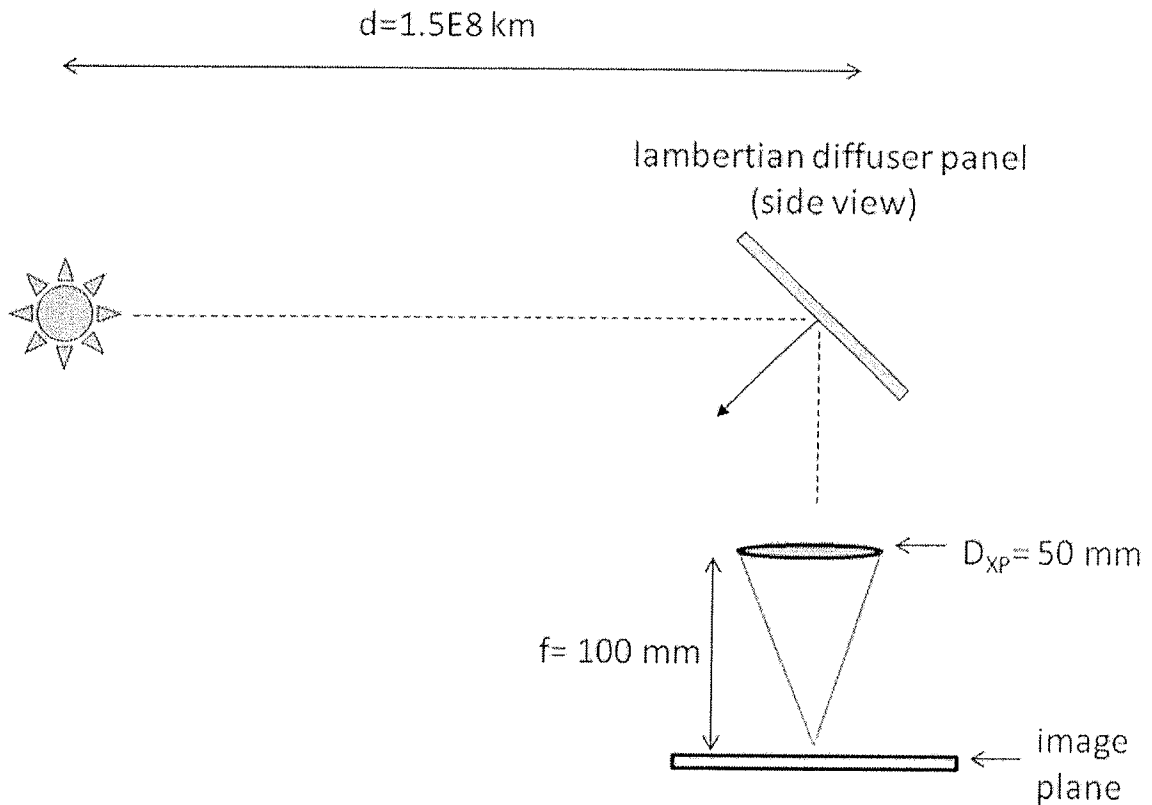

1. Calculate the radiant flux, Φ , of the sun, assuming it is a point source.
2. Calculate the irradiance, $E_{\text{on axis image}}$, at the image plane of the instrument for an on-axis point.
3. Calculate the irradiance, $E_{\text{off axis image}}$, at the image plane of the instrument for an off-axis point that is 30° off-axis.
4. Rotate the lambertian diffuser panel and instrument so that the angle between the diffuser panel normal and the sun is now 30° , and maintain the angle between the diffuser-panel normal and the instrument at 45° . Calculate the resulting irradiance, E_{new} , at the image plane of the instrument for an on-axis point.

. Chromatic dispersion and short pulse

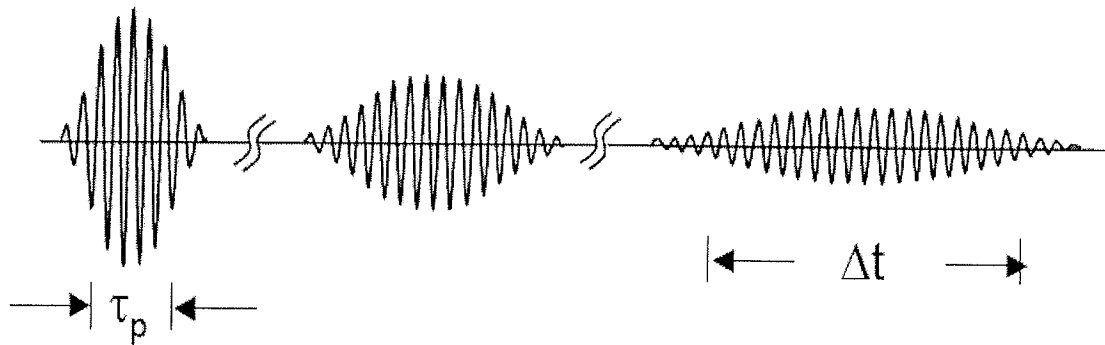

A Gaussian pulse has a time-bandwidth product given by $\Delta f_p \tau_p \approx 0.44$, where Δf_p is the pulse bandwidth in Hz and τ_p is the pulse width in time. The speed of light in vacuum is c_0 . The pulse propagates inside a type of glass with refractive index given by

$$n(\omega) = \frac{A}{\omega} + B\omega + C\omega^2 + D.$$

Here $\omega = 2\pi f$ and f is the frequency.

- What is the phase velocity of the pulse, v_p ? (2 points)
- What is the group velocity of the pulse, v_g ? (2 points)
- What is the dispersion coefficient, D_v ? (3 points)
- How long (in time) does it take for the pulse to spread to twice its original width (in time) if it is propagating through this material? You can express the answer in terms of the group velocity. (3 points)

a) Sketch the attenuation in dB/km for a typical silica optical fiber (used in modern Telecommunications) as a function of wavelength within the wavelength range of 800 nm - 1800 nm. The sketch should show the distinct features of the attenuation spectrum and give an approximate value for the minimum attenuation.

(4 points)

b) Very briefly explain how it, in principle, could be possible to further reduce the minimum attenuation if:

(1 point)

- i) you are limited to using a silica based fiber.
- ii) you can use fibers made using other materials.

c) Describe a double-heterostructure for laser diodes (draw a simplified “flat band configuration” under strong forward bias, indicate energy levels and location of holes and electrons).

(2 points)

d) mention the three key advantages that a double heterostructure offers in laser diodes compared to a simple homojunction.

(3 points)

Consider a standard brightfield optical microscope imaging system with Koehler illumination. The system has an objective marked 20X/0.5 and an eyepiece marked 10X. A slide mirror can also be inserted to direct the light to a CCD camera for digital recording. The coupling optical component that images the intermediate image plane of the microscope onto the CCD is marked 1X.

1. Explain the meaning of the numbers 20X and 0.5 on the objective, 10X on the eyepiece, and 1X on the coupling optics. Be precise in your explanation.
2. Write down an expression for the Rayleigh criterion and use it to determine the minimum separation of two resolvable points in the object plane. You can assume the light has a wavelength of 500 nm.
3. There are two apertures in the Koehler illumination system. One is marked field aperture and the other is marked condenser aperture. Describe what each of these apertures controls in terms of the illumination light distribution at the object plane.
4. What two radiometric quantities are used to describe the important properties of (1) the light distribution coming from the object plane and (2) the light distribution at the CCD detector? Provide appropriate units for each of these quantities. You can ignore the spectral distribution of the light for your answer to this question.
5. Is the system mapping from object distribution to CCD digital image generally (1) linear and (2) shift invariant? Explain your answers.

The following questions, all related to diffraction and its role in imaging, are equally weighted.

- (a) In words, what is a monochromatic plane wave?
- (b) Give a *general* mathematical expression for a monochromatic plane wave, carefully explaining all symbols and conventions used.
- (c) What condition must be satisfied for the expression in part (b) to be a solution of the time-dependent wave equation in a source-free region of free space?
- (d) In words, what is a monochromatic spherical wave? Give a *general* mathematical expression for a monochromatic spherical wave, carefully explaining all symbols and conventions used.
- (e) Consider a monochromatic point source at the origin in a 3D space, $(x, y, z) = (0, 0, 0)$. Give an *approximate* expression for the field near the z axis in the plane $z = z_0$.
- (f) Now suppose there is an ideal, thin, positive lens of focal length f and aperture diameter D in the plane $z = z_0$, centered on $x = 0, y = 0$. Using the result of part (e), give an expression for the wave emerging from the lens and explain the result.
- (g) Determine where the wave emerging from the lens in part (f) comes to a focus, and sketch the field in that plane. Indicate the scale on your sketch.